

# SERVICE Manual

---

## COMPUTER CONTROLLED VARIABLE SPEED RV GENERATORS

Series NP-30G and NP-40G

# GENERAC

---

P. O. Box 8  
PHONE: (414) 544-4811

Waukesha, Wisconsin 53187  
FAX: (414) 544-4851

---

## **SAFETY**

Throughout this publication, "DANGER!" and "CAUTION!" blocks are used to alert the mechanic to special instructions concerning a particular service or operation that might be hazardous if performed incorrectly or carelessly. **PAY CLOSE ATTENTION TO THEM.**

### **DANGER!**

**UNDER THIS HEADING WILL BE FOUND SPECIAL INSTRUCTIONS WHICH, IF NOT COMPLIED WITH, COULD RESULT IN PERSONAL INJURY OR DEATH.**

### **CAUTION!**

**Under this heading will be found special instructions which, if not complied with, could result in damage to equipment and/or property.**

These "Safety Alerts" alone cannot eliminate the hazards that they signal. Strict compliance with these special instructions plus "common sense" are major accident prevention measures.

## **NOTICE TO USERS OF THIS MANUAL**

This **SERVICE MANUAL** has been written and published by Generac to aid our dealers' mechanics and company service personnel when servicing the products described herein.

It is assumed that these personnel are familiar with the servicing procedures for these products, or like or similar products manufactured and marketed by Generac. That they have been trained in the recommended servicing procedures for these products, including the use of common hand tools and any special Generac tools or tools from other suppliers.

Generac could not possibly know of and advise the service trade of all conceivable procedures by which a service might be performed and of the possible hazards and/or results of each method. We have not undertaken any such wide evaluation. Therefore, anyone who uses a procedure or tool not recommended by Generac must first satisfy himself that neither his nor the products safety will be endangered by the service procedure selected.

All information, illustrations and specifications in this manual are based on the latest product information available at the time of publication.

When working on these products, remember that the electrical system and engine ignition system are capable of violent and damaging short circuits or severe electrical shocks. If you intend to perform work where electrical terminals could be grounded or touched, the battery cables should be disconnected at the battery.

Any time the intake or exhaust openings of the engine are exposed during service, they should be covered to prevent accidental entry of foreign material. Entry of such materials will result in extensive damage when the engine is started.

During any maintenance procedure, replacement fasteners must have the same measurements and strength as the fasteners that were removed. Metric bolts and nuts have numbers that indicate their strength. Customary bolts use radial lines to indicate strength while most customary nuts do not have strength markings. Mismatched or incorrect fasteners can cause damage, malfunction and possible injury.

## **REPLACEMENT PARTS**

Components on Generac recreational vehicle generators are designed and manufactured to comply with Recreational Vehicle Industry Association (RVIA) Rules and Regulations to minimize the risk of fire or explosion. The use of replacement parts that are not in compliance with such Rules and Regulations could result in a fire or explosion hazard. When servicing this equipment, it is extremely important that all components be properly installed and tightened. If improperly installed and tightened, sparks could ignite fuel vapors from fuel system leaks.

# SERVICE MANUAL

## COMPUTER CONTROLLED VARIABLE SPEED RV GENERATORS

Series NP-30G and NP-40G

PART	TITLE
1	THE AC GENERATOR
2	ENGINE MECHANICAL
3	GASOLINE FUEL SYSTEM
4	GASEOUS FUEL SYSTEM
5	ENGINE OIL & COOLING SYSTEM
6	ENGINE ELECTRICAL SYSTEM
7	TROUBLESHOOTING
8	SPECIFICATIONS & CHARTS

# Part 1 THE AC GENERATOR

**COMPUTER  
CONTROLLED  
VARIABLE  
SPEED RV  
GENERATORS**  
Series NP-30G and NP-40G

SECTION	TITLE
1.1	GENERATOR FUNDAMENTALS
1.2	GENERATOR MAJOR COMPONENTS
1.3	OPERATIONAL ANALYSIS
1.4	INSULATION RESISTANCE
1.5	COMPONENTS TESTING
1.6	CONTROL PANEL
1.7	SHEET METAL

# Section 1.1- GENERATOR FUNDAMENTALS

## Magnetism

Magnetism can be used to produce electricity and electricity can be used to produce magnetism.

Much about magnetism cannot be explained by our present knowledge. However, there are certain patterns of behavior that are known. Application of these behavior patterns has led to the development of generators, motors and numerous other devices that utilize magnetism to produce and use electrical energy.

See Figure 1. The space surrounding a magnet is permeated by magnetic lines of force called "flux". These lines of force are concentrated at the magnet's north and south poles. They are directed away from the magnet at its north pole, travel in a loop and re-enter the magnet at its south pole. The lines of force form definite patterns which vary in intensity depending on the strength of the magnet. The lines of force never cross one another. The area surrounding a magnet in which its lines of force are effective is called a "magnetic field".

Like poles of a magnet repel each other, while unlike poles attract each other.

Figure 1. Magnetic Lines of Force

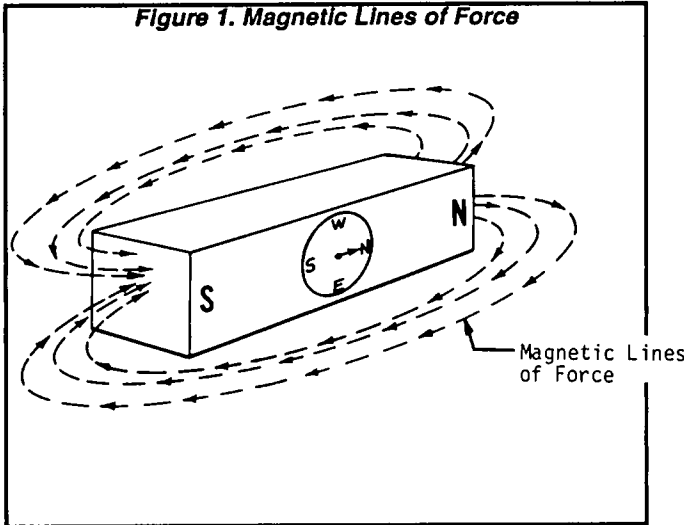

## Electromagnetic Fields

All conductors through which an electric current is flowing have a magnetic field surrounding them. This field is always at right angles to the conductor. If a compass is placed near the conductor, the compass needle will move to a right angle with the conductor. The following rules apply:

- The greater the current flow through the conductor, the stronger the magnetic field around the conductor.
- The increase in the number of lines of force is directly proportional to the increase in current flow and the field is distributed along the full length of the conductor.
- The direction of the lines of force around a conductor can be determined by what is called the "right hand rule". To apply this rule, place your right hand around the conductor with the thumb pointing in the direction of current flow. The fingers will then be pointing in the direction of the lines of force.

NOTE: The "right hand rule" is based on the "current flow" theory which assumes that current flows from positive to negative. This is opposite the "electron" theory, which states that current flows from negative to positive.

Figure 2. The Right Hand Rule

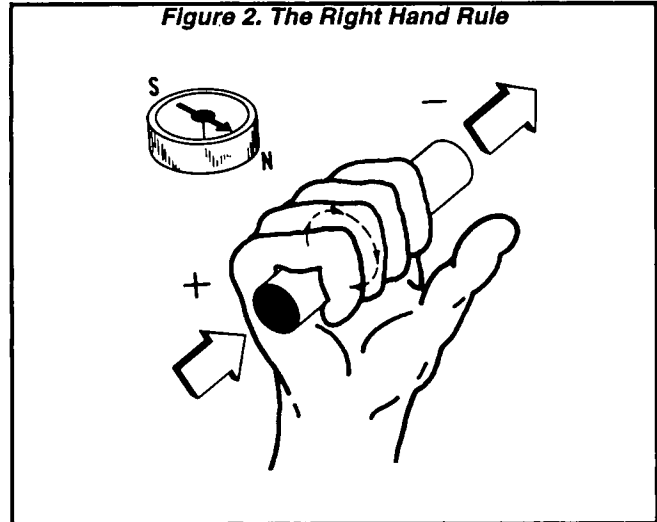

## Electromagnetic Induction

An electromotive force (EMF) or voltage can be produced in a conductor by moving the conductor so that it cuts across the lines of force of a magnetic field.

Similarly, if the magnetic lines of force are moved so that they cut across a conductor, an EMF (voltage) will be produced in the conductor. This is the basic principle of the revolving field generator.

Figure 3, below, illustrates a simple revolving field generator. The permanent magnet (Rotor) is rotated so that its lines of magnetic force cut across a coil of wires called a Stator. A voltage is then induced into the Stator windings. If the Stator circuit is completed by connecting a load (such as a light bulb), current will flow in the circuit and the bulb will light.

Figure 3. A Simple Revolving Field Generator

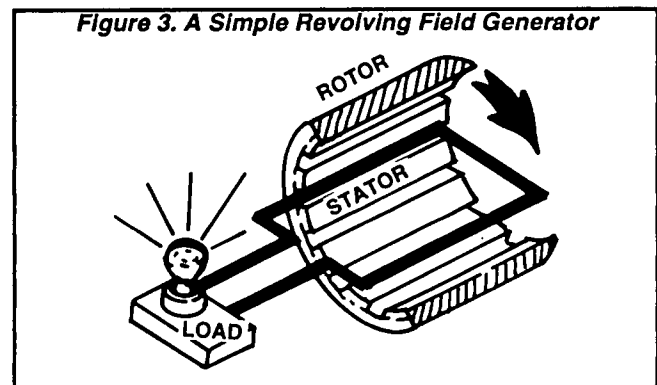

## Alternating Current

A simple generator consists of a coil of wires called a Stator and a magnetic field called a Rotor. As the Rotor's magnetic field cuts across the Stator coil, a voltage is induced into the Stator windings. The amount of induced voltage is equal to the strength of the magnetic field.

# Section 1.1- GENERATOR FUNDAMENTALS

## Alternating Current (Continued)

See Figure 4. The current alternates according to the position of the Rotor's poles in relation to the position of the Stator. At 0° and again at 180°, no current flow is produced. At 90° of Rotor rotation, current flow reaches a maximum positive value. Rotor rotation to 270° brings another maximum flow of current. However, at 270° the current flow has reversed in polarity and now flows in the opposite direction.

## Electrical Units

### AMPERE:

The rate of electron flow in a circuit is represented by the AMPERE. The ampere is the number of electrons flowing past a given point at a given time. One AMPERE is equal to just slightly more than six thousand million billion electrons per second.

Figure 4. Operation of a Simple Generator

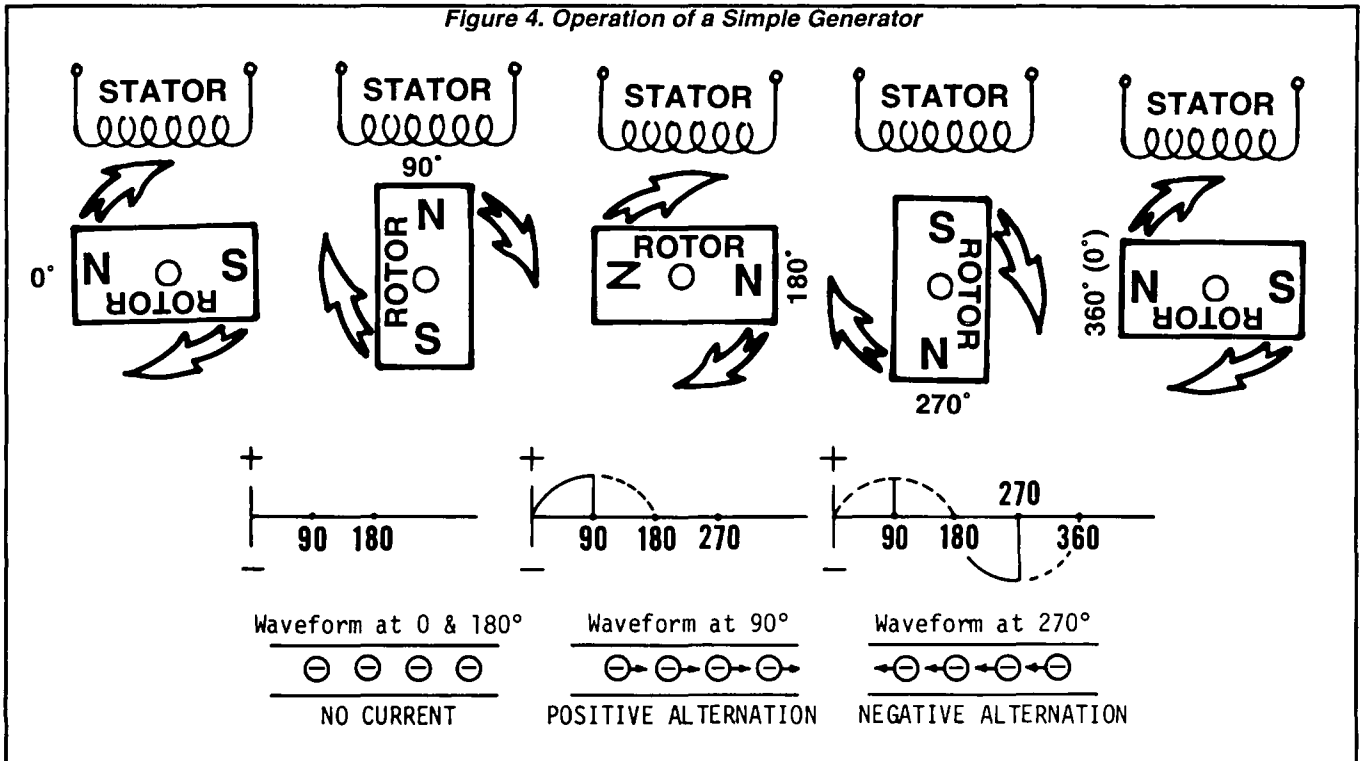

With alternating current (AC), the electrons flow first in one direction, then reverse and move in the opposite direction. They will repeat this cycle at regular intervals. A wave diagram, called a "sine wave" shows that current goes from zero to maximum positive value, then reverses and goes from zero to maximum negative value. Two reversals of current flow is called a cycle. The number of cycles per second is called frequency and is usually stated in "Hertz".

### VOLT:

The VOLT is the unit used to measure electrical PRESSURE, or the difference in electrical potential that causes electrons to flow. Very few electrons will flow when voltage is weak. More electrons will flow as voltage becomes stronger. VOLTAGE may be considered to be a state of unbalance and current flow as an attempt to regain balance. One volt is the amount of EMF that will cause a current of 1 ampere to flow through 1 ohm of resistance.

Figure 5. Alternating Current Sine Wave

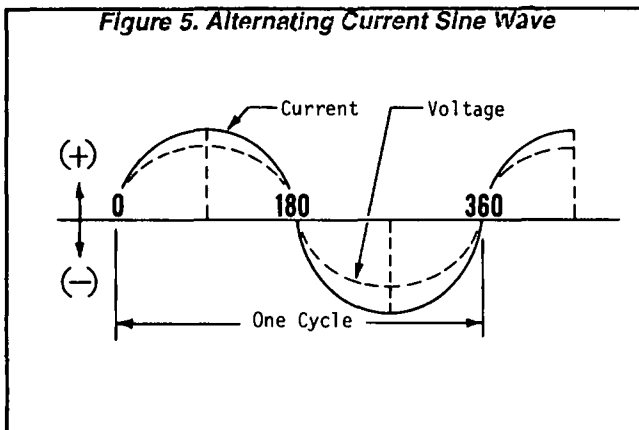
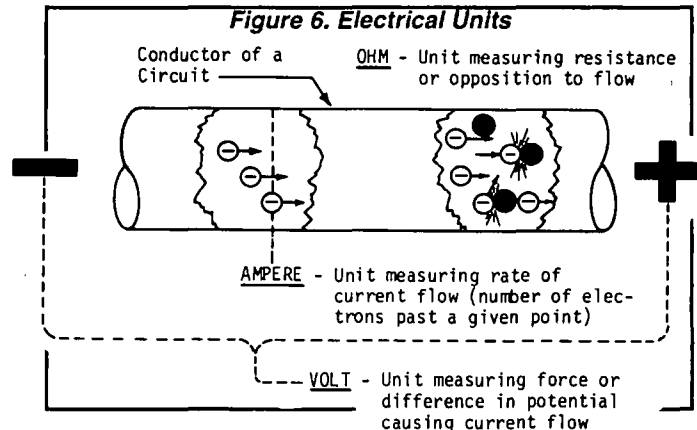

Figure 6. Electrical Units



# Section 1.1- GENERATOR FUNDAMENTALS

## OHM:

The OHM is the unit of RESISTANCE. In every circuit there is a natural resistance or opposition to the flow of electrons. When an EMF is applied to a complete circuit, the electrons are forced to flow in a single direction rather than their free or orbiting pattern. The resistance of a conductor depends on (a) its physical makeup, (b) its cross-sectional area, (c) its length, and (d) its temperature. As the conductor's temperature increases, its resistance increases in direct proportion. One (1) ohm of resistance will permit one (1) ampere of current to flow when one (1) volt of electromotive force (EMF) is applied.

## Ohm's Law

A definite and exact relationship exists between VOLTS, OHMS and AMPERES. The value of one can be calculated when the value of the other two are known. Ohm's Law states that in any circuit the current will increase when voltage increases but resistance remains the same, and current will decrease when resistance increases and voltage remains the same.

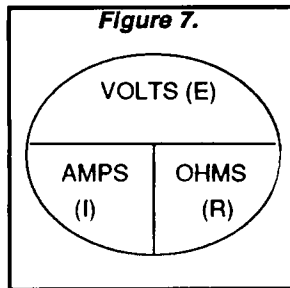

If AMPERES is unknown while VOLTS and OHMS are known, use the following formula:

$$\text{AMPERES} = \frac{\text{VOLTS}}{\text{OHMS}}$$

If VOLTS is unknown while AMPERES and OHMS are known, use the following formula:

$$\text{VOLTS} = \text{AMPERES} \times \text{OHMS}$$

If OHMS is unknown but VOLTS and AMPERES are unknown, use the following:

$$\text{OHMS} = \frac{\text{VOLTS}}{\text{AMPERES}}$$

## Reactance in AC Circuits

### GENERAL:

When direct current (DC) is flowing, the only opposition to current flow that must be considered is resistance (ohms). This is also true of alternating current (AC) when only resistance type loads such as heating and lamp elements are on the circuit. In such a case, current will be in phase with voltage- that is, the current sine wave will coincide in time with the voltage sine wave.

However, two factors in AC circuits called INDUCTIVE and CAPACITIVE REACTANCE will prevent the voltage and current sine waves from being in phase.

### INDUCTIVE REACTANCE:

This condition exists when current lags behind voltage (Figure 8). As current flows in a circuit, magnetic lines of force are created at right angles to the conductor. The continuous changes in current value (from positive to negative) cause these magnetic lines to collapse and build up continuously.

The magnetic field around the conductor induces electromotive forces that cause current to keep on flowing while voltage drops. The result is a condition in which voltage leads current. When a conductor is formed into a coil, the magnetic lines of force are concentrated in the center of the coil. This increased density causes an increase in magnetically induced EMF without increasing current. Thus, coils cause inductive reactance.

Inductive reactance can also be caused by placing an induction motor on the circuit which utilizes the current's magnetic field for excitation.

Figure 8. Inductive Reactance

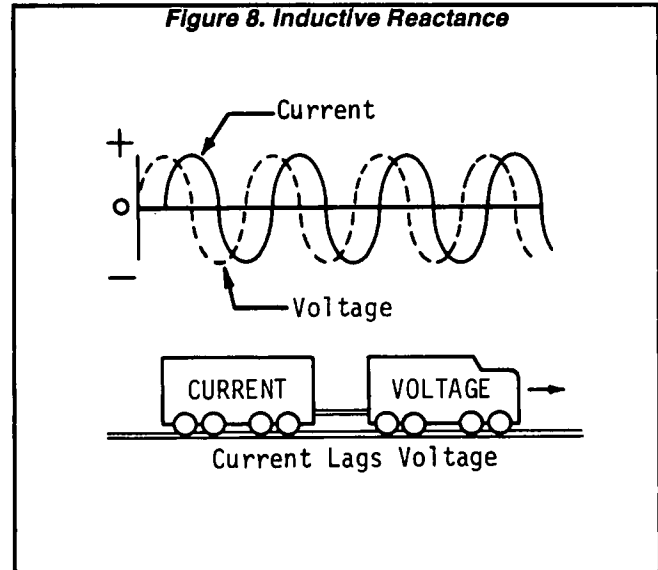

### CAPACITIVE REACTANCE:

This condition occurs when current leads voltage (Figure 9). It might be thought of as the ability to oppose change in voltage. Capacitance exists in a circuit when certain devices are (a) capable of storing electrical charges as voltage increases and (b) discharging these stored charges when the voltage decreases.

Figure 9. Capacitive Reactance

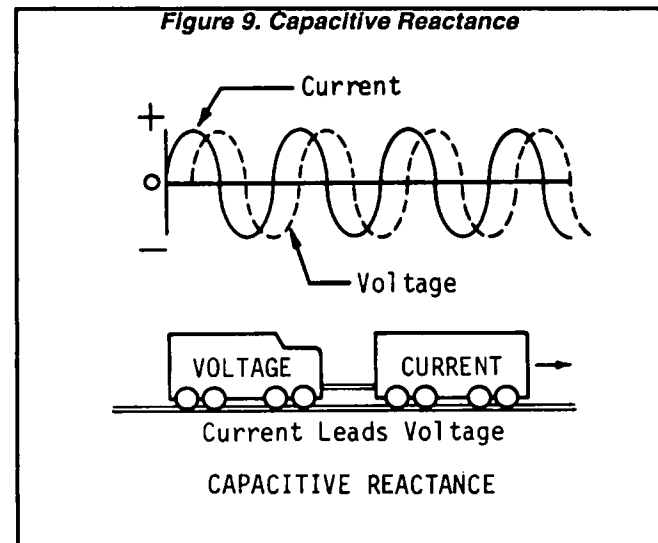

# Section 1.1- GENERATOR FUNDAMENTALS

## Introduction to CCG's

### WHAT IS A "CCG"?:

The initials "CCG" stand for "computer controlled generator". Such units are different from conventional generators in that the performance of the engine and AC generator are more accurately matched over a wide range of power needs. The CCG's provide greater efficiency of both the engine and the generator while maintaining electrical output within an acceptable voltage and frequency band.

CCG units have the ability to operate the engine over a wide range of speeds, while conventional generators will deliver correct AC frequency and voltage only at a fixed rpm. The unit's electrical output is fed through an AC-AC converter which reconstructs electrical waveforms to the correct output frequency.

Unlike conventional AC generators, the CCG can match engine speed to load requirements. This provides several advantages, as follows:

- Smaller engines can be used to produce more power than on a conventional generator, since it can be allowed to run at a higher speed.
- When the load is reduced, the engine can run at slower than the usual speeds. This improves fuel economy and reduces engine noise.
- The CCG unit can be operated closer to its peak power point at all times, because output voltage and current are functions of engine speed. This allows for a much more compact generator design.

### CCG SYSTEM OVERVIEW:

Figure 10 is a block diagram of the CCG system. The major elements of the system are represented

in the diagram. Operation of the system may be described briefly as follows:

1. The engine is directly coupled to a permanent magnet type Rotor, so the Rotor runs at the same speed as the engine.
2. As the Rotor turns, its magnetic field cuts across the Stator windings to induce a voltage into the Stator.

- a. The Stator is a 2-phase type with center tap.
- b. Stator AC output frequency is between 336 and 540 Hertz. This corresponds to engine speeds of 2520 to 4050 rpm.
- c. The load requires a nominal AC frequency of 60 Hertz. Thus, the generated frequency is six to nine times the desired range.

3. A Frequency Converter changes the high frequency output to a useful frequency, i.e., one that is compatible with load requirements of about 60 Hertz.

4. A Voltage Detector circuit senses load voltage and signals a System Control circuit.

5. The System Control circuit establishes the REQUIRED ENGINE SPEED for correct voltage and delivers an output to an Engine Controller.

6. The Engine Controller adjusts the engine's Throttle to change engine speed and establish the correct AC output voltage.

7. The following facts should be apparent:

- LOAD FREQUENCY IS CONTROLLED BY THE "FREQUENCY CONVERTER" DEVICE.
- VOLTAGE IS CONTROLLED BY A "SYSTEM CONTROL" CIRCUIT WHICH CHANGES ENGINE SPEED TO MAINTAIN A CONSTANT VOLTAGE AT VARYING ELECTRICAL LOADS.

Figure 10. Block Diagram of CCG System

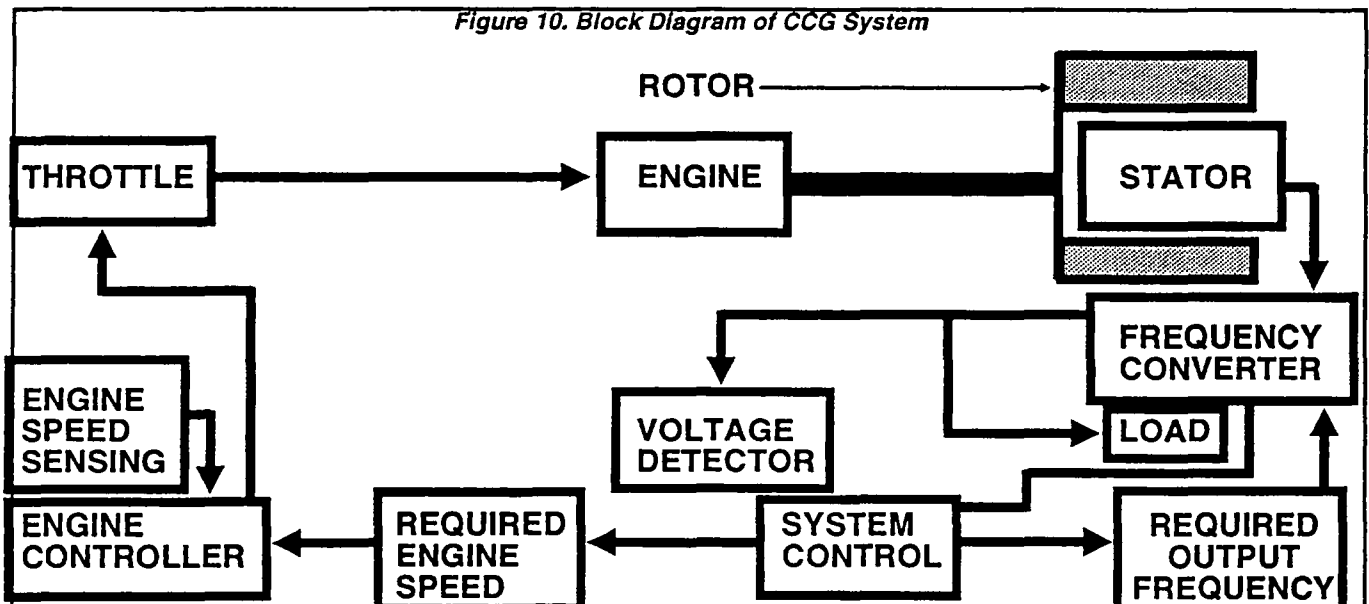



## Section 1.1- GENERATOR FUNDAMENTALS

---

### *Why Variable Speed Control?*

Most electrical loads will operate satisfactorily only within a relatively small voltage band. In order to provide useful voltage at larger load currents, it is necessary to increase engine speed.

In conventional AC generators, some form of voltage regulation is needed to provide correct voltage in the full range of load current. This is often accomplished by regulating excitation current to the Rotor (field) which then regulates the strength of the Rotor's magnetic field. The voltage induced into the Stator windings is proportional to the strength of the Rotor's magnetic field.

The CCG uses a Rotor having a fixed and permanent magnetic field. The strength of this magnetic field is fixed and cannot be regulated.

The output voltage on CCG generators tends to droop with increasing electrical loads. The SYSTEM CONTROLLER maintains a constant AC output voltage by increasing engine and Rotor speed as the load current increases, to offset this inherent voltage droop.

The SYSTEM CONTROLLER also selects the correct number of generator pulses which are combined to form each 60 Hertz "half-cycle".

# **Section 1.1- GENERATOR FUNDAMENTALS**

---

# Section 1.2- MAJOR GENERATOR COMPONENTS

## Introduction

Major components of the generator proper are shown in Figure 1, below. External sheet metal and other unrelated components are omitted from the drawing for clarity. These parts are:

ITEM	NOMENCLATURE
1	Upper Fan Housing
2	Upper Cooling Fan
3	Permanent Magnet Rotor
4	Rotor Hub
5	Stator Retaining Ring
6	Stator Assembly
7	Stator Adapter
8	Engine
9	Lower Fan & Flywheel
10	Stepper Motor

Figure 1. Exploded View of Generator Proper

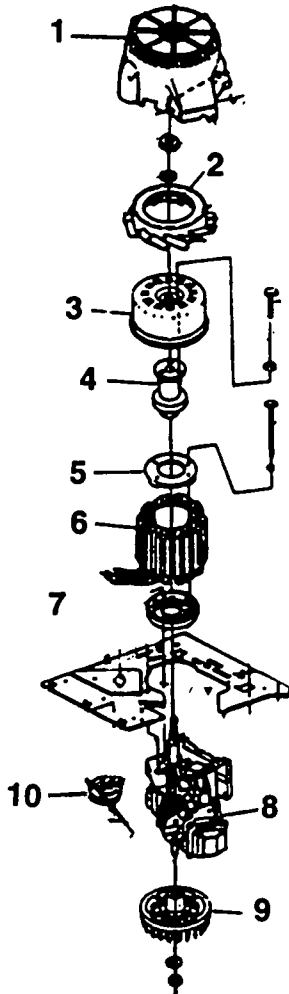

## Upper Fan Housing

As its name implies, this component houses and shields the upper cooling fan. See Figure 1, Item 1.

## Upper Cooling Fan

The Cooling Fan draws air into the generator through slots in the Upper Fan Housing. It is fastened to and rotates with the Permanent Magnet Rotor.

## Permanent Magnet Rotor

Sixteen permanent magnets have been affixed to the Rotor. A starter ring gear is welded to the Rotor. The Rotor and Hub are balanced at the factory as an assembly and must be replaced as an assembly.

**NOTE:** The hub **MUST** be properly aligned during reassembly. The mounting bolt, housing opening and magnet must be properly aligned. In addition, match marks between the Hub and Rotor must be aligned as indicated by an "ALIGN MARKS FOR BALANCE" decal. During assembly, use care to avoid damage to the Ignition Sensor.

### DANGER!

**THE PERMANENT MAGNET ROTOR PRODUCES AN EXTREMELY STRONG MAGNETIC FORCE. USE CARE DURING INSTALLATION TO AVOID PINCHED FINGERS.**

Figure 2. Permanent Magnet Rotor Assembly

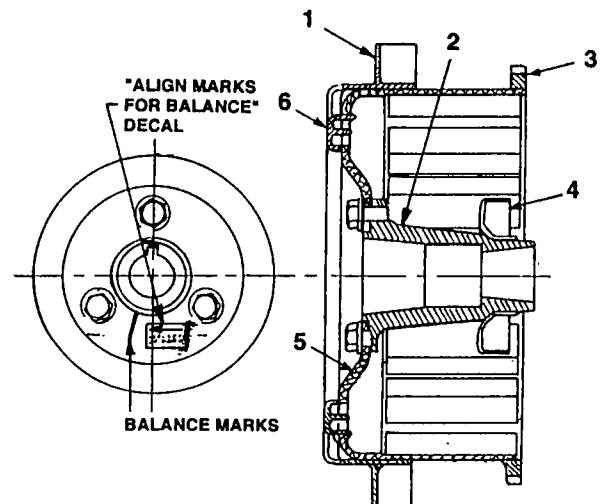

- 1. Fan
- 2. Hub
- 3. Ring Gear
- 4. Ignition Cage
- 5. Rotor
- 6. Fan Clips

# Section 1.2- MAJOR GENERATOR COMPONENTS

## Rotor Hub

See Figure 2. The Rotor Hub is balanced with the Rotor and must be replaced with the Rotor as an assembly. Part of the engine ignition system is pressed onto the Hub and can be replaced only as part of the Rotor and Hub assembly.

## Stator Retaining Ring

The Stator Retaining Ring is made of die-cast aluminum. Four hex head capscrews with lockwashers pass through holes in the Retaining Ring, to retain the Stator Assembly to the Stator Adapter (Item 7, Figure 1).

## Stator Assembly

The 2-phase Stator is made up of eight (8) windings, with leads brought out as shown in figure 3. Figure 4 is a schematic representation of each stator winding. Note that there are four (4) power phase windings (Leads AC2, AC1, SL2, SL1 and 11); a timing winding (Leads TIM1 and TIM2); a power supply winding (Leads PS1, PS2); and a dual battery charge winding (Leads 55, 66, 77).

The Stator produces a frequency of 336 to 540 Hertz, which corresponds to engine speeds between 2520 and 4050 rpm. This means the generated frequency is between six and nine times the desired frequency of about 60 Hertz.

## Stator Adapter

The Adapter is retained to the engine by means of four hex head capscrews. The Stator is retained to the Stator Adapter and is "sandwiched" between the Adapter and the Stator Retaining Ring.

## Lower Fan & Flywheel

The Lower Fan and Flywheel are retained to the engine PTO shaft by means of a conical washer and an M16-1.50 hex nut. When assembling, tighten the flywheel nut to 75 foot-pounds.

## Engine

The engine is a single cylinder, overhead valve type manufactured by Generac Corporation. Depending on the specific generator Model Number, either a GN-190 or a GN-220 engine is used on NP-30 and NP-40 RV generators.

## Stepper Motor

The Stepper Motor (Figure 5, next page) consists of a stepper motor along with a gear and cam arrangement which allows motor movement to change the engine carburetor throttle setting. The Motor is controlled by output signals from the Computer Control Circuit Board, which calculates the number of steps the stepper needs to take and generates the required signals to the Motor. The circuit board signals the Motor to actuate in re-

ponse to changes in AC output voltage. Thus, in response to decreasing AC output voltages, the Motor will increase the throttle setting and engine speed will increase. Conversely, increasing AC output voltages will cause the Motor to decrease throttle setting and engine speed will decrease.

Figure 3. Stator Pictorial View

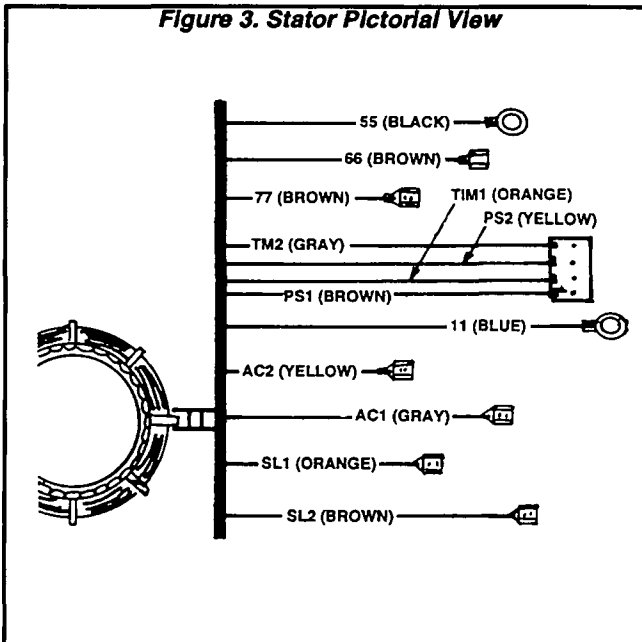
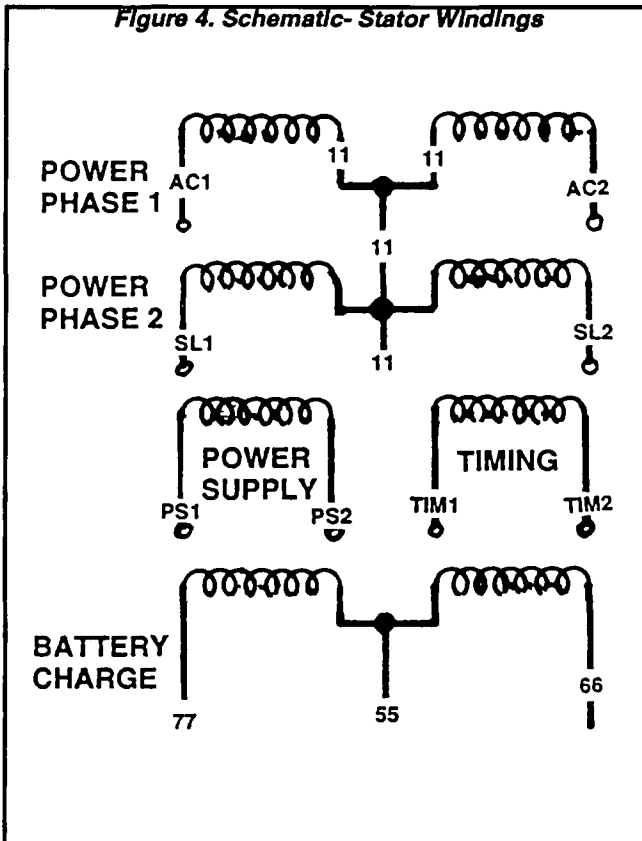
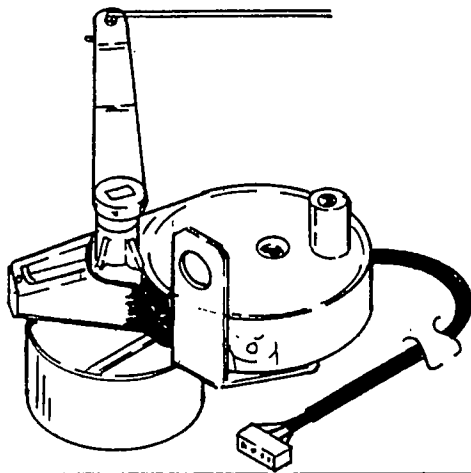

Figure 4. Schematic- Stator Windings



## Section 1.2- MAJOR GENERATOR COMPONENTS

Figure 5. The Stepper Motor



### The Genistor

#### GENERAL:

See Figure 6. The GENISTOR is often called a "frequency converter" (also see "Introduction to CCG's" on Page 1.1-4). Its function is to change the high frequency AC output of the Stator (336-540 Hertz) to a useful frequency (about 56-60 Hertz). The Genistor has no intelligence of its own. It is simply a high speed switching device which is controlled by the CCG circuit board.

Figure 6. The Genistor

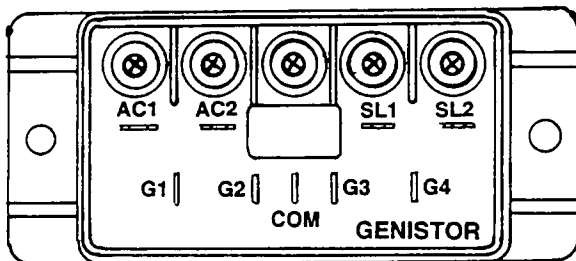

#### GENISTOR THEORY:

The purpose of a "frequency converter" is to divide the Stator AC output frequency by an integral factor to provide a useful output frequency. Each of the four half-phases of the center-tapped Stator is Genistor-controlled.

Figure 7 shows the sine wave output from the 2-phase Stator windings. This output is delivered to the Genistor switching module.

Switching signals from the CCG circuit board are also delivered to the Genistor. These signals switch the Genistor on and off as required, resulting in a sine wave output to the load as shown in Figure 8.

Figure 7. Stator Output Sine Wave Pattern

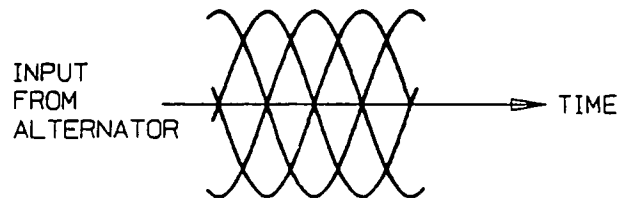
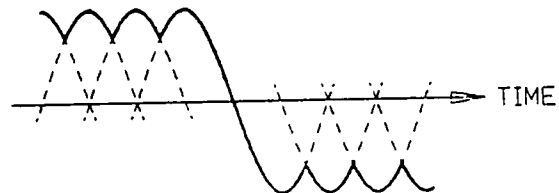

Figure 8. Genistor Corrected Sine Wave Pattern



### The CCG Circuit Board

#### GENERAL:

The CCG circuit board has several functions as follows:

1. It controls the operation of the "frequency converter" (Genistor).
2. It controls AC output voltage under all load requirements by controlling engine speed.
3. It protects the system against various faults.

#### FREQUENCY CONTROL:

The CCG board will adjust the number of alternator cycles in one output cycle to control AC output frequency. The number of cycles is based on engine rpm and the output frequency will be maintained in the 55-65 Hertz band.

The board uses a "zero crossing" detector to synchronize an internal clock. The frequency of the Stator's waveform is measured and, with reference to the required output frequency, a "frequency divisor" is calculated. The circuit board then signals the Genistor (frequency converter) to switch on and off at the proper times so that frequency is maintained in the 55-65 Hertz band.

# Section 1.2- MAJOR GENERATOR COMPONENTS

## The CCG Circuit Board (Continued)

### VOLTAGE CONTROL:

The CCG circuit board utilizes a closed-loop, proportional-derivative controller which regulates RMS voltage by changing engine speed. The system maintains output voltage at about 115 volts at the lowest rpm and 120 volts up to the maximum rpm.

The board controls a Stepper Motor (Figure 5), which moves the throttle. The board calculates the number of steps the Motor needs to take and signals the Motor to move. Motor movement changes throttle position and changes in engine speed result.

### FAULT PROTECTION:

The CCG board has the ability to detect several fault conditions and shut the engine down, as follows:

1. Overvoltage:- If the output voltage exceeds 127 VAC for longer than 15 seconds, the board will turn AC output power off and shut the engine down.
2. Undervoltage:- If output remains below about 96 VAC longer than 15 seconds, an overload condition probably exists. The board will then turn AC output off and shut the engine down.
3. Overspeed:- If engine speed exceeds 4500 rpm, shutdown will occur.
4. Failure of the Genistor (frequency converter) will result in engine shutdown.
5. Loss of output to any circuit connected to the board will result in engine shutdown.

### CIRCUIT BOARD CONNECTIONS:

The board is equipped with eight (8) connection points (receptacles). These are identified as "CONN1" through "CONN8". See Figure 9.

CONNECTOR	FUNCTION
CONN1	Six-pin connector Interconnects with speed control Stepper Motor.
CONN2	12-pin connector is NOT used on RV units. An orange jumper wire is connected across Pins 5 & 11.
CONN3	7-pin connector interconnects with the Genistor.
CONN4	4-pin receptacle for connection of the Stator power supply leads (PS1, PS2) and the Stator timing leads (TIM1, TIM2).
CONN5	Single point connection for Stator lead No. 11 (blue).
CONN6	Interconnects with the Genistor.
CONN7	Single point connector is NOT used on RV units.
CONN8	Single point connector for Wire 18B. Interconnects with Engine Controller circuit board, allows the CCG board to shut the engine down.

Figure 9. The CCG Circuit Board

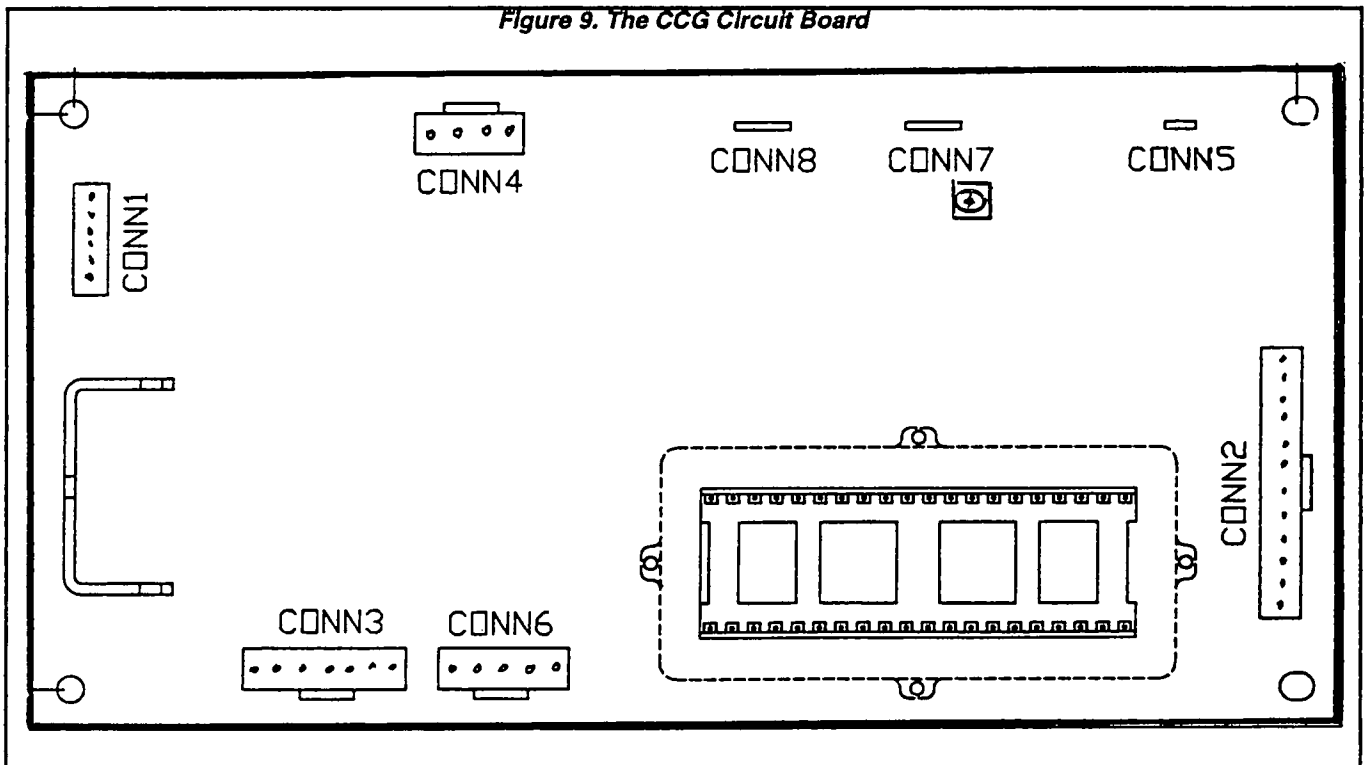

# Section 1.3- OPERATIONAL ANALYSIS

## General

Figure 1, below, is a block diagram of the computer controlled RV generator. The diagram is intended only for the purpose of illustrating generator operation. Refer to the actual wiring diagram for wiring interconnections.

## Operational Description

1. The PERMANENT MAGNET ROTOR is directly coupled to the ENGINE and rotates at the same speed as the engine.
2. As the ROTOR turns, its magnetic field cuts across a number of STATOR windings, to induce a voltage into those windings. A voltage is induced into the following STATOR windings:
  - a. Phase 1 and 2 of the STATOR POWER WINDINGS (output leads AC1-AC2 and SL1-SL2).
  - b. The STATOR POWER SUPPLY WINDING with output leads PS1-PS2.
  - c. The STATOR TIMING WINDING (output leads TIM1-TIM2).
  - d. STATOR BATTERY CHARGE WINDING with output leads 55, 66 and 77.

3. STATOR BATTERY CHARGE WINDING output is delivered to the unit battery via a BATTERY CHARGE RECTIFIER (BCR) and a 1 OHM, 50 WATT RESISTOR. The circuit is completed through the battery to frame ground and back to the BATTERY CHARGE WINDING via Wire 55.
4. STATOR TIMING WINDING output is delivered to the CCG CIRCUIT BOARD. The circuit board measures the frequency of the waveform and calculates a "frequency divisor" to maintain a useable frequency to the CUSTOMER CONNECTION regardless of rpm.
5. The STATOR POWER SUPPLY WINDING output is delivered to the CCG CIRCUIT BOARD. This is the power supply for operation of the circuit board and GENISTOR.
6. STATOR POWER WINDING OUTPUT (Phase 1 and 2) is delivered to a GENISTOR. The GENISTOR is a high-speed switching device which is controlled by the CCG board.
7. The CCG CIRCUIT BOARD senses voltage and frequency and then acts to control voltage and frequency as follows:

Figure 1. Block Diagram- AC Generator System

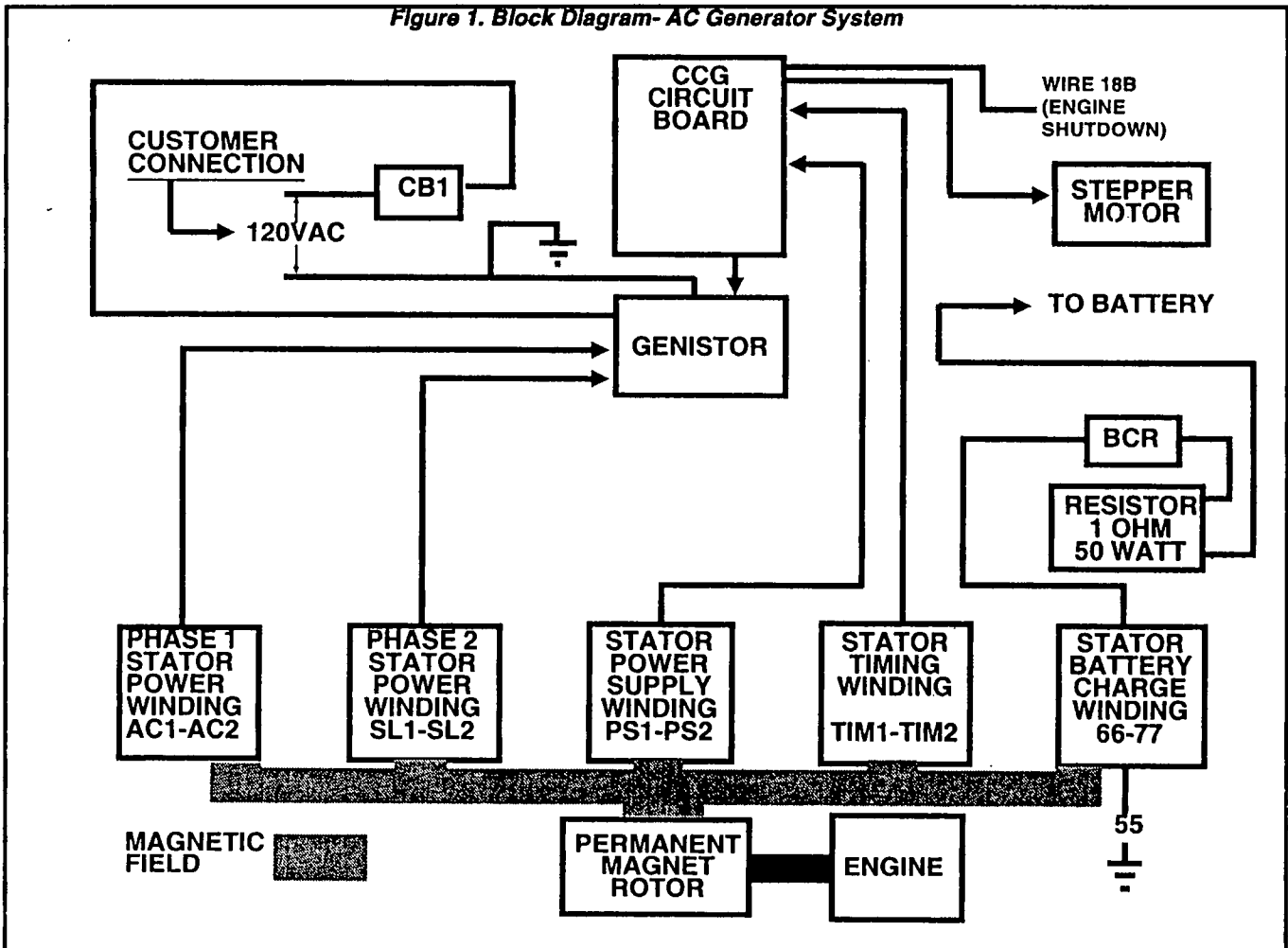

## Section 1.3- OPERATIONAL ANALYSIS

---

### *Operational Description (Continued)*

a. The circuit board senses actual voltage and "compares" it to a pre-set "reference" voltage of about 115-120 volts AC.

(1) If voltage is low, the board will signal a STEPPER MOTOR to change engine throttle setting and increase speed until the desired voltage level is reached.

(2) If voltage goes high, the board will signal the STEPPER MOTOR to reduce engine throttle setting until the desired voltage level is obtained.

(3) Engine speed is variable and is used to control output voltage and may range from about 2520 to 4050 rpm.

b. The CCG board controls AC frequency by acting on the GENISTOR.

(1) The GENISTOR is a high speed switching device.

(2) The CCG board signals the Genistor to switch generator waveforms on and off at the proper times, in order to maintain a frequency in the 55-65 Hertz band.

8. The CCG circuit board can protect the system against some faults by shutting the engine down. Wire 18B is the "engine shutdown" lead that connects this system to the Engine Controller circuit board. See "FAULT PROTECTION", Page 1.2-4.



# Section 1.4- INSULATION RESISTANCE

## Dirt and Moisture

If moisture is permitted to remain in contact with the generator Stator windings, some of it will be retained in voids and cracks of the winding insulation. This can eventually cause a reduction in insulation resistance and generator output may be affected.

Winding insulation in Generac generators is moisture resistant. However, prolonged exposure to water, high humidity, salt air, etc., will gradually reduce the resistance of winding insulation.

Dirt can make the problem even worse, since it tends to hold moisture into contact with the windings. Salt, as from sea air, can also worsen the problem, since salt tends to absorb moisture from the air. When salt and moisture combine, they make a good electrical conductor.

Because of the detrimental effects of water, dirt and salt, the generator should be kept as dry and as clean as possible. Stator windings should be tested periodically using a Hi-Pot tester or a Megohmmeter. If insulation resistance is low, drying of the unit may be necessary. If resistance is still low after drying, the defective Stator should be replaced.

## Insulation Resistance Testers

One kind of insulation resistance tester is shown in Figure 1, below. Other types are commercially available. The type shown has a "Breakdown" lamp which turns on to indicate an insulation breakdown during the test.

One common type of tester is the "Megohmmeter" which measures resistance in "Megohms".

### CAUTION!

When using a Megohmmeter or any other tester, be sure to follow the manufacturer's instructions carefully. All Stator leads must be isolated from other components, especially circuit boards, before performing tests. The high voltages used in testing insulation resistance will damage electronic components.

## Stator Leads

The following leads are brought out of the Stator and connected to various components in the unit:

Figure 1. One Kind of Hi-Pot Tester

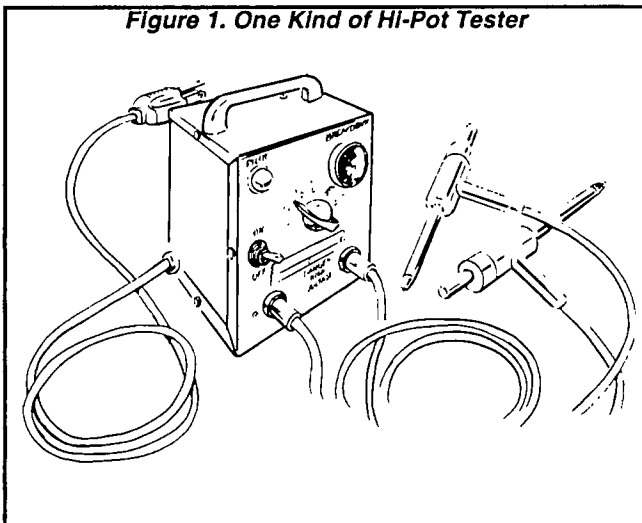

WIRE NO.	COLOR	CONNECTS TO
11	Blue	Main Circuit Breaker CB1
77	Brown	Battery Charge Rectifier BCR
66	Brown	Battery Charge Rectifier BCR
55	Black	Grounding Terminal
SL2	Brown	Genistor (G)
SL1	Orange	Genistor (G)
AC2	Yellow	Genistor (G)
AC1	Gray	Genistor (G)
PS1	Brown	CCG Circuit Board (CCB)
TIM1	Orange	CCG Circuit Board (CCB)
PS2	Yellow	CCG Circuit Board (CCB)
TIM2	Gray	CCG Circuit Board (CCB)

Figure 2. Stator Leads

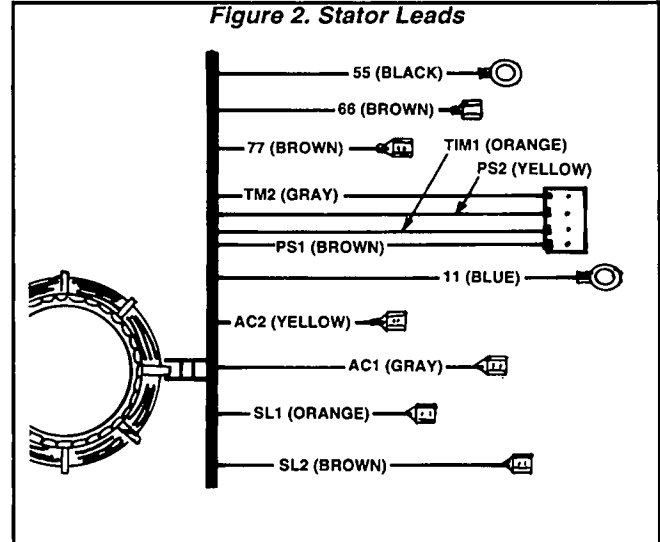

## Preparation for Tests

See Stator leads CHART above. Disconnect and isolate all Stator leads. ALL STATOR LEADS MUST BE DISCONNECTED AND ISOLATED BEFORE STARTING THE TESTS.

## Test All Stator Windings to Ground

Connect the ends of all Stator leads together. Make sure none of the leads are touching any terminal or any part of the generator.

Connect one Tester probe to the junction of all Stator leads; the other Tester probe to a clean frame ground on the Stator. Apply a voltage of 1000 volts for about 1 second.

Follow the tester manufacturer's instructions carefully. Some "Hi-Pot" testers are equipped with a "Breakdown" light which will turn ON to indicate an insulation breakdown.

A "Megger" (Megohmmeter) will indicate the "megohms" of resistance. Normal Stator winding insulation resistance is on the order of "millions of ohms" or "megohms". The MINIMUM acceptable insulation resistance reading for Stators can be calculated using the following formula.

$$\text{MINIMUM INSULATION RESISTANCE (In "megohms")} = \frac{\text{GENERATOR RATED VOLTS}}{1000} + 1$$

# Section 1.4- INSULATION RESISTANCE

## Test All Stator Windings to Ground (Continued)

**EXAMPLE:** Generator rated voltage is "120 VAC". Divide 120 by 1000 to obtain "0.12". Add "1" to obtain "1.12". Minimum insulation resistance for the unit is "1.12 megohms".

### Test for Shorts Between Windings

Figure 2 on the previous page shows the Stator leads that are brought out of the Stator. Figure 3 is a schematic representation of the eight (8) Stator windings. To test for shorts between windings, proceed as follows:

1. Make sure all Stator output leads are isolated from each other and from the frame.
2. **POWER PHASE TO TIMING WINDINGS:-** Connect one tester probe to Stator lead No. 11, the other test probe to Stator lead TIM1. Apply a voltage of 1000 volts. The Tester will indicate a breakdown if the windings are shorted together.
3. **POWER PHASE TO POWER SUPPLY WINDINGS:** Connect one tester probe to Stator lead No. 11, the other tester probe to Stator lead PS1. Apply 1000 volts. If a breakdown is indicated, the windings are shorted together.
4. **POWER PHASE TO BATTERY CHARGE WINDINGS:-** Connect one tester probe to Stator Lead No. 11, the other probe to Stator lead No. 55. Apply 1000 volts. If breakdown is indicated, the windings are shorted together.
5. **TIMING TO POWER SUPPLY WINDING:-** Connect one tester probe to Stator lead No. TM1, the other test probe to Stator lead No. PS1. Apply 1000 volts. If breakdown is indicated, the windings are shorted together.
6. **TIMING TO BATTERY CHARGE WINDING:-** Connect one test probe to Stator lead No. TIM1, the other test probe to Stator lead No. 55. Apply 1000 volts. If breakdown is indicated the windings are shorted together.
7. **POWER SUPPLY TO BATTERY CHARGE WINDING:-** Connect one test probe to Stator lead No. PS1, the other probe to Stator lead No. 55. Apply 1000 volts. If breakdown is indicated, the windings are shorted together.

### Results of Tests

1. If testing indicates that Stator windings are shorted to ground, the Stator should be cleaned and dried. The insulation resistance tests should then be repeated. If, after cleaning and drying, the Stator again fails the test, replace the Stator assembly.
2. If testing indicates that a short between windings exists, clean and dry the Stator. Then, repeat the tests. If Stator fails a second test (after cleaning and drying), replace the Stator assembly.

### Cleaning the Generator

#### GENERAL:

If testing indicates that the insulation resistance is below a safe value, the winding should be cleaned. Proper cleaning can be accomplished only while the generator is disassembled. The cleaning method used should be determined by the type of dirt to be removed. Be sure to dry the unit after it has been cleaned. An electric motor repair shop may be able to assist with cleaning. Such shops are often experienced in special problems (sea coast, marine, wetland applications, etc.).

Figure 3. Schematic- Stator Windings

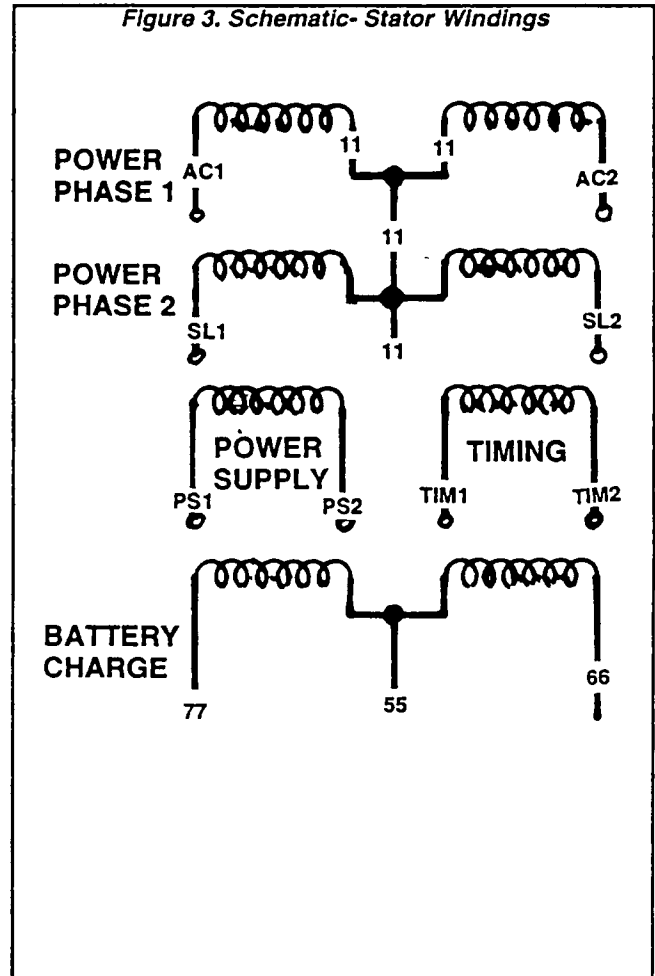

#### USING SOLVENTS FOR CLEANING:

A solvent is generally required when dirt contains oil or grease. Only petroleum distillates should be used to clean electrical components. Recommended are safety type petroleum solvents having a flash point greater than 100° F. (38° C.).

Use a soft brush or cloth to apply the solvent. Use care to avoid damaging magnet wire or winding insulation. After cleaning, dry all components thoroughly with moisture-free, low pressure compressed air.

#### DANGER!

DO NOT WORK WITH SOLVENTS IN ANY ENCLOSED AREA. ALWAYS PROVIDE ADEQUATE VENTILATION. FIRE, EXPLOSION OR OTHER HEALTH HAZARDS MAY EXIST UNLESS ADEQUATE VENTILATION IS PROVIDED. WEAR EYE PROTECTION. WEAR RUBBER GLOVES TO PROTECT THE HANDS.

#### CAUTION!

Some generators use epoxy or polyester base winding varnishes. Use solvents that do not attack such materials.

## Section 1.4- INSULATION RESISTANCE

---

### *Drying the Generator*

#### GENERAL:

If testing indicates that the insulation resistance of a winding is below a safe value, the winding should be dried before operating the unit. Some recommended drying methods include (a) heating units and (b) forced air.

#### HEATING UNITS:

If drying is needed, the generator can be enclosed in a covering. Heating units can then be installed to raise the temperature about 15°-18° F. (8°-10° C.) above ambient.

#### FORCED AIR:

Portable forced air heaters can be used to dry the generator. Direct the heated air into the generator's air intake openings. Run the unit at no-load. Air temperature at the point of entry into the generator should not exceed 150° F. (66° C.).

# **Section 1.4- INSULATION RESISTANCE**

---

# Section 1.5- COMPONENTS TESTING

## Introduction

Problems that occur in the computer-controlled RV generator generally involve the following systems or components:

1. The engine.
2. The Speed Control System.
3. The AC Generator.
4. The Genistor.
5. Battery Charge Circuit.
6. CCG Circuit Board.
7. Wiring Harness and Front Panel.

This Section will discuss test procedures for the following components. Also see Part 8 of this Manual, "TROUBLESHOOTING".

1. The AC Generator (Stator).
2. The Genistor.
3. Battery Charge Circuit.
4. CCG Circuit Board.

## Stator Assembly

### GENERAL:

For additional information on the Stator, refer to the following:

1. "Stator Assembly" on Page 1.2-2.
2. Section 1.4, "INSULATION RESISTANCE".

### SYMPTOMS OF STATOR FAILURE:

A. If the engine starts but the Stepper Motor does not move, and shutdown occurs after several seconds, look for the following:

1. Broken or shorted Power Supply winding (Wires PS1 and PS2).
2. Broken or shorted Timing winding (Wires TIM1 and TIM2).

**NOTE:** If the Power Supply winding is shorted to ground, a burned area on the CCG circuit board (circuit board ground track) may be visible. If the Timing winding is shorted to ground, the circuit will probably be damaged but burn-up may not be visible.

B. If the engine shuts down but speed did NOT exceed 4500 rpm, look for the following:

1. One of the main windings (Power Phase 1 or 2) is open.
2. One of the main windings (Power Phase 1 or 2) is shorted to ground.

### TESTING THE STATOR WITH A VOM:

A Volt-Ohm-Milliammeter (VOM) can be used to test the Stator windings for the following faults:

- An open circuit condition.
- A "short-to-ground" condition.

- A short circuit between windings.

**NOTE:** The resistance of Stator windings is very low. Some meters will not read such a low resistance and will simply indicate "continuity". Recommended is a high quality, digital type meter capable of reading very low resistances.

### TESTING POWER PHASE WINDINGS:

A. Refer to Figures 1 and 2. To test the Power Phase windings for an open circuit condition, proceed as follows:

1. Disconnect the following wires:
  - a. Lead "AC1" (Gray) at the Genistor.
  - b. Lead "AC2" (Yellow) at the Genistor.
  - c. Lead "SL1" (Orange) at the Genistor.
  - d. Lead "SL2" (Brown) at the Genistor.
  - e. Lead No. 11 (Blue) at the Main Circuit Breaker (CB1).
2. Make sure all of the disconnected leads are isolated from each other and are not touching the frame during the test.
3. Set a VOM to its "Rx1" scale and zero the meter.
4. Connect one VOM test lead to Lead No. 11 (Blue). Then, connect the remaining test lead as follows:
  - a. To Lead AC1 and note the resistance reading.
  - b. To Lead AC2 and note the resistance reading.
  - c. To lead SL1 and note the resistance reading.
  - d. To lead SL2 and note the resistance reading.

NOMINAL RESISTANCE- POWER PHASE WINDINGS  
0.30 to 0.42 ohm

Figure 1. Schematic- Stator Windings

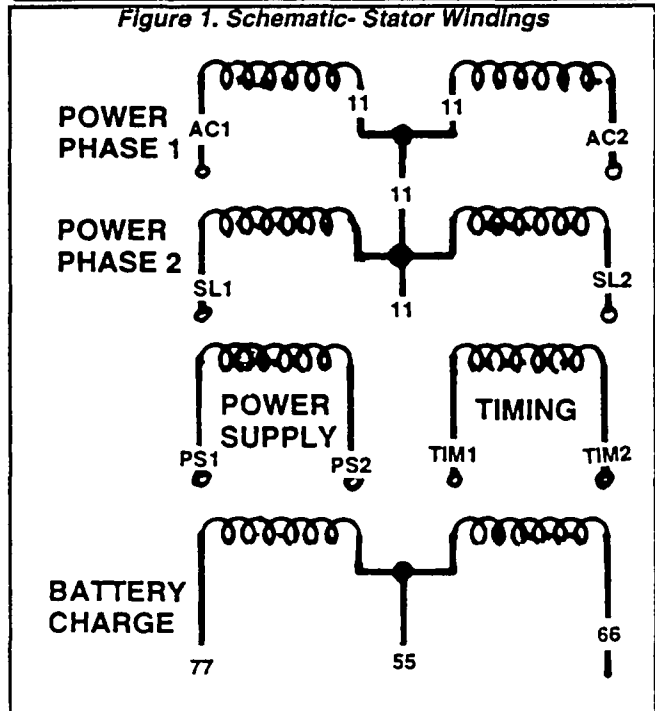

# Section 1.5- COMPONENTS TESTING

## Stator Assembly (Continued)

### TESTING POWER PHASE WINDINGS (CONT'D):

B. To test the Power Phase windings for a "short-to-ground" condition, proceed as follows:

1. Make sure all leads are isolated from each other and are not touching the frame.
2. Set a VOM to its "Rx10,000" or "Rx1K" scale and zero the meter.
3. Connect one VOM test lead to the terminal end of Lead "AC1", the other test lead to a clean frame ground on the Stator.
  - a. The meter should read "Infinity".
  - b. Any reading other than "Infinity" indicates a "short-to-ground" condition.

**NOTE:** Any reading other than "Infinity" indicates the winding is shorted to ground. If winding is open or shorted, the Stator should be replaced.

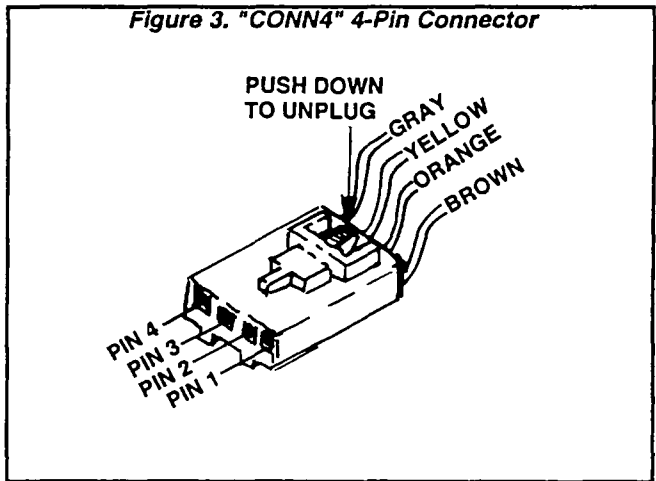
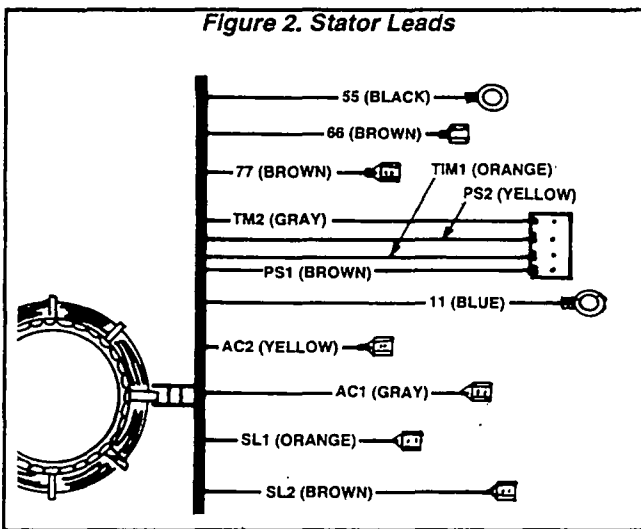

### TESTING THE TIMING WINDING:

A. To test the Stator Timing winding for an open circuit condition, proceed as follows:

1. Disconnect the 4-pin connector from "CONN4" of the CCG circuit board. See Figure 3.
  - a. Stator lead TIM1 (Orange) connects to Pin 2 of the 4-pin connector.
  - b. Stator lead TIM2 (Gray) connects to Pin 4 of the 4-pin connector.
2. Set a VOM to its "Rx1" scale and zero the meter.
3. Connect one VOM test lead to Pin 2 (Lead TIM1-Orange); connect the other test lead to Pin 4 (Lead TIM2- Gray). The meter should indicate the Stator Timing winding resistance.

**NOMINAL RESISTANCE  
STATOR TIMING WINDING  
0.35-0.44 ohm**

### TESTING POWER SUPPLY WINDINGS:

A. To test the Power Supply winding for an open circuit condition, proceed as follows:

1. Disconnect the 4-pin connector from "CONN4" of the CCG circuit board. See Figure 3.
  - a. Stator lead "PS1" (Brown) connects to Pin 1 of the connector.
  - b. Stator lead "PS2" (Yellow) connects to Pin 3 of the connector.
2. Set a VOM to its "Rx1" scale and zero the meter.
3. Connect one VOM test lead to Pin 1 (Lead PS1-Brown), the other test lead to Pin 3 (Lead PS2- Yellow). The meter should indicate the resistance of the Power Supply winding.

**NOMINAL RESISTANCE  
POWER SUPPLY WINDING  
0.35-0.44 ohm**

B. To test the Power Supply winding for a "short-to-ground" condition, proceed as follows:

1. Set the VOM to its "Rx10,000" or "Rx1K" scale and zero the meter.
2. Connect one VOM test lead to Pin 1 (Lead PS1-Brown). Connect the other test lead to a clean frame ground on the Stator. The meter should read "infinity".

B. To test the Timing winding for a "short-to-ground" condition, proceed as follows:

1. Set the VOM to its "Rx10,000" or "Rx1K" scale and zero the meter.
2. Connect one VOM test lead to Pin 2 of the 4-pin connector (Lead TIM1-Orange).
3. Connect the other test lead to a clean frame ground on the Stator. The meter should read "infinity". Any reading other than "Infinity" indicates the Timing winding is shorted to ground.

### SHORT CIRCUIT BETWEEN WINDINGS:

To test for a short circuit between windings, proceed as follows:

1. Set a VOM to its "Rx10,000" or "Rx1K" scale and zero the meter.
2. Connect one meter test lead to Stator lead PS1 (Brown).
3. Connect the remaining test lead to Stator lead AC1 (Gray). The meter should read "infinity". Any reading other than "infinity" indicates a shorted condition and the Stator should be replaced.

## Section 1.5- COMPONENTS TESTING

4. Connect one VOM test lead to Stator lead AC1, the other test lead to Stator lead 77. The VOM should read "Infinity".

5. Connect one VOM test lead to Stator lead AC1, the other test lead to Stator lead TIM1. The meter should read "Infinity".

6. Connect one test lead to Stator lead PS1, the other to Stator lead TIM1. "Infinity" should be indicated.

7. Connect one test lead to Stator lead PS1, the other to Stator lead 77. The VOM should read "Infinity".

8. Connect one VOM test lead to Stator lead TIM1, the other test lead to Stator lead 77. "Infinity" should be indicated.

### Genistor

#### GENERAL:

The "Genistor" or "Triac Module" is the FREQUENCY CONVERTER for the generator. For additional information on the Genistor, refer to "The Genistor" on Pages 1.2-3 and 1.2-4.

#### SYMPTOMS OF GENISTOR FAILURE:

If the engine shuts down but speed did not exceed 4500 rpm, the following problems may exist:

1. Loss of the "Gate" connection (G1 through G4) between the CCG circuit board and the Genistor.

2. Although the correct "Gate" signal is received from the CCG board, one or more switches are not gating.

3. The Genistor is not gating properly, i.e., one or more switches are permanently turned on.

4. Open circuit or loss of connection(s) between Stator and Genistor (Leads AC1, AC2, SL1, SL2, 22).

5. Open circuit or loss of connection between Genistor and CCG circuit board (Leads AC1, AC2, SL1, SL2).

#### TESTING THE GENISTOR:

Disconnect all wires from the Genistor before attempting to test it.

#### CAUTION!

DO NOT attempt to test the Genistor until ALL leads have been disconnected. The genistor MUST be completely disconnected from the circuit. If testing is accomplished with any leads connected, all test results are invalid.

See Figure 4. To test the Genistor, proceed as follows:

1. Set a VOM to a resistance scale that will allow a range of about 20-60 ohms to be read. Zero the meter.

2. Connect one VOM test leads to the "COM" terminal and the other test lead to Terminals G1, G2, G3 and G4 one at a time. Read the resistance as the meter is connected to G1, to G2, to G3, and to G4.

#### RESISTANCE READING

"COM" to G1 = 20-60 Ohms  
 "COM" to G2 = 20-60 Ohms  
 "COM" to G3 = 20-60 Ohms  
 "COM" to G4 = 20-60 Ohms

3. Set the VOM to its "Rx1" scale and zero the meter. Then connect the VOM test leads across the "COM" terminal and the center screw. The VOM should read "continuity".

4. Now, connect the VOM test leads across the following terminals and screws:

a. Across AC1 screw to AC1 terminal should read "continuity".

b. Across AC2 screw to AC2 terminal should read "continuity".

c. Across SL1 screw to SL1 terminal should read "continuity".

d. Across SL2 screw to SL2 terminal should read "continuity".

5. Set the VOM to its "Rx10,000" or "Rx1K" scale and zero the meter. Then, connect the VOM test leads across each of the screws. There should be no continuity between any of the screws ("infinity").

*NOTE: The resistance reading between any two of the screws on the Genistor is in the neighborhood of about 1 megohm (about 1 million amps). If the Genistor failed any of the preceding tests, it should be replaced.*

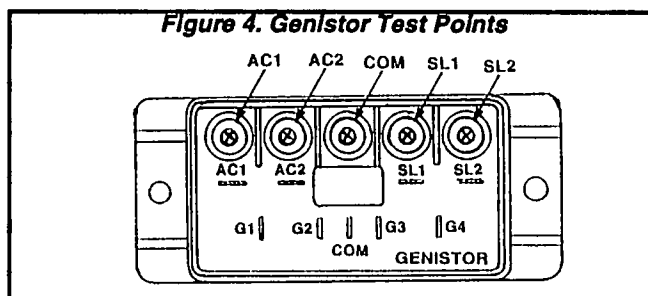

### Testing the Battery Charge Circuit

#### GENERAL:

The Stator is equipped with dual battery charge windings. These windings deliver an AC output to a Battery Charge Rectifier (BCR) which rectifies it (changes it to direct current or DC). The direct current is delivered to the unit battery, to maintain the battery in a charged state while the unit is running.

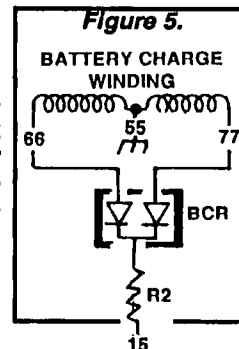

# Section 1.5- COMPONENTS TESTING

## Testing the Battery Charge Circuit (Continued)

### SYMPTOMS OF CIRCUIT FAILURE:

It is difficult to determine if the battery charge circuit is operating without testing for correct voltage. If you suspect the battery charge circuit is defective, the following symptoms will usually point to a cause of the problem. See Figure 6.

1. If no AC voltage can be measured across Stator connections at the Battery Charge Rectifier (BCR), an open circuit condition probably exists in Wire 66 (Brown), or Wire 77 (Brown).
2. If AC voltage is available to the Wire 66 and 77 terminals at the battery Charge Rectifier, but no voltage or a low voltage is measured between the BCR's Wire 55 terminal and ground, the Battery Charge Rectifier (BCR) is defective.

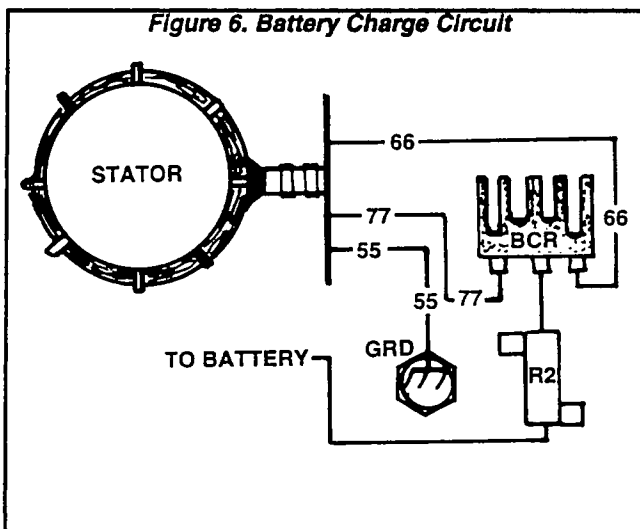

### TESTING THE BATTERY CHARGE CIRCUIT:

Test the Battery Charge winding as follows:

1. Disconnect Wire 77 at the Battery Charge Rectifier (BCR).
2. Disconnect Stator output Wire 66 at the Battery Charge Rectifier (BCR).
3. Disconnect Wire 55.
4. Set a VOM to its "Rx1" scale and zero the meter.
5. Connect the VOM test leads across Wires 77 and 55, then across Wires 66 and 55. Note the resistance reading in both cases. Replace Stator Assembly, if defective.

**BATTERY CHARGE WINDING RESISTANCE  
ACROSS WIRES 66 TO 55 = 0.037-0.042 Ohm  
ACROSS WIRES 77 TO 55 = 0.037-0.042 Ohm**

6. Use a VOM to measure AC voltage at the Wires 66 and 77 terminals of the Battery Charge Rectifier, with the unit running. If no AC voltage is measured, an open circuit exists in the wire 66 or 77 circuit.

7. With engine running, use a VOM to check for DC voltage between the Battery Charge Rectifiers Wire 55 and frame ground. If AC voltage was present in step 6, but DC voltage is NOT present in this stem, the Battery Charge Rectifier (BCR) is defective.

## Testing the CCG Circuit Board

### GENERAL:

It is difficult if not impossible to test the CCG circuit board in the field. Generally, if the other components in the AC generator system have tested good, you may assume that any problem is in the CCG circuit board.

**NOTE:** Also refer to "CCG Circuit Board" on Pages 1.2-4, 1.2-5, and 1.2-6.

### SYMPTOMS OF CIRCUIT BOARD FAILURE:

1. If the engine starts, but the Stepper Motor does not move, and engine shuts down after several seconds, the CCG circuit board's micro-controller may not be operating.
2. A failure of the circuit board's Stepper Motor drive can result in the following:
  - a. Engine starts, but Stepper Motor does not move. The engine accelerates uncontrollably and shuts down when engine speed exceeds 4500 rpm.
  - b. Engine starts, but Stepper Motor does not move. The following symptoms occur:
    - (1) Engine appears to operate too slowly.
    - (2) Engine is not able to handle the load and unit operates at low AC output voltage.
    - (3) After several seconds under load, AC output voltage is turned off (overload condition).
3. If the engine can be started, but shuts down after several seconds, a timing detection failure may have occurred (Timing winding, Wires TIM1, TIM2).
4. If the engine speed and output voltage are erratic under constant load, but the AC output does not turn off intermittently, erratic timing detection may have occurred (Timing winding, Wires TIM1, TIM2).

**NOTE:** Timing detection involves the circuit board's ability to detect "zero crossings" of the sine wave (see "Alternating Current", Pages 1.1-1 and 1.1-2). The CCG circuit board must detect both zero VOLTAGE and zero CURRENT crossings if the system is to operate properly. This "zero crossing" detector is used to synchronize an internal clock on the circuit board. The frequency of the input waveform is measured by the circuit board and checked against a "reference" frequency. The board then calculates a frequency divisor. By counting "zero voltage crossings", an internal reference output polarity is generated. The Genlstor switch with the maximum potential in the direction of the internal reference is gated.



## Section 1.5- COMPONENTS TESTING

---

### TESTING THE CIRCUIT BOARD:

There is no practical way of testing the CCG circuit board in the field. Read "SYMPTOMS OF CIRCUIT BOARD FAILURE" carefully. Test the Stator, the Genistor, and the Battery Charge circuit as outlined in this Section. Also perform a resistance test of the Stepper Motor (see Part 7, "THE VARIABLE SPEED SYSTEM") and observe its operation if possible.

Inspect wiring and wiring connections between the CCG circuit board and the Genistor as follows (refer to appropriate wiring diagram):

1. Check wires G1 through G4 (and Wire 22) for proper connections at circuit board and at the Genistor.
2. Use a VOM to check Wires G1 through G4 (and Wire 22) for continuity.
3. Check Wires AC1, AC2, SL1 and SL2 (between circuit board and Genistor) for proper connections.
4. Use a VOM to check Wires AC1, AC2, SL1, SL2 (between circuit board and Genistor) for continuity.

If all tests are completed and no problem is found on other components of the system, replace the CCG circuit board and check unit operation.

## **Section 1.5- COMPONENTS TESTING**

---

# Section 1.6- CONTROL PANEL

## Construction

The panel is constructed of sheet metal and includes a panel box, a panel back cover and a front control panel. The panel box is retained to an engine-generator divider plate by five M5 screws. Removal of these screws will permit the panel to be removed from the divider plate and set out of the way with connecting wires still attached. This will allow access to components housed in the control panel.

## Components

A heat sink bracket is attached to the engine-generator divider plate, for attachment of a heat sink to which a CCG circuit board and Genistor are mounted. See Items 26, 31, 32 and 38 in the Exploded View of Control Panel. Other components are also shown in the Exploded View. Many of these components are part of the "ENGINE ELECTRICAL SYSTEM" (Part 6 of this manual).

Figure 1. Exploded View of Control Panel

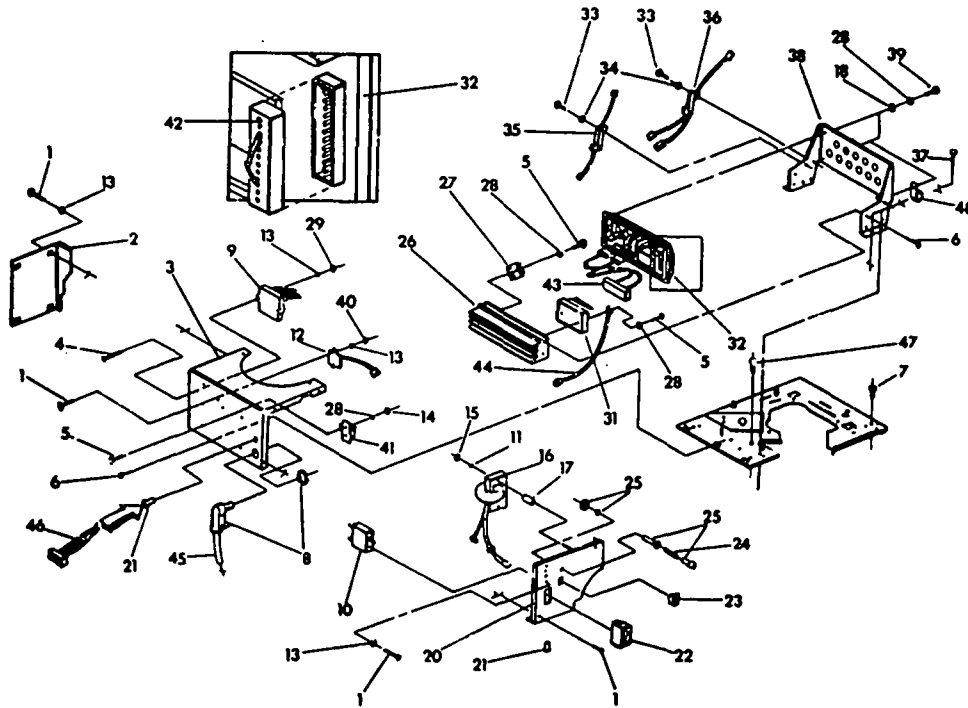

ITEM	QTY	DESCRIPTION	ITEM	QTY	DESCRIPTION
1	6	M5 Pan Head Machine Screw	26	1	Heat Sink
2	1	Back Panel Cover	27	1	Battery Charge Rectifier
3	1	Control Panel Box	28	9	M4 Lockwasher
4	2	No. 10-32 Pan Head Screw	29	2	No. 10-32 Hex Nut
5	5	M4 Pan Head Screw	31	1	Genistor
6	8	M5 Screw	32	1	CCG Printed Circuit Board
7	1	Snap Bushing	33	4	M3 Pan Head Screw
8	1	90° Connector	34	4	M3 Lockwasher
9	1	Engine Controller Circuit Board	35	1	1 ohm Power Resistor
10	1	25 amp circuit breaker	36	1	500 ohm Power Resistor
11	2	M6 Lockwasher	37	4	M6 Screw
12	1	Ignition Module	38	1	Heat Sink Bracket
13	8	M5 Lockwasher	39	4	M4 Pan Head Screw
14	2	M4 Hex Nut	40	2	M5 Hex Nut
15	2	M6 Hex Nut	41	1	Terminal Block
16	1	Ignition Coil Assembly	42	1	12-pin Connector
17	2	Ignition Coil Spacer	43	1	Genistor Harness
18	4	No. 8 Flatwasher	44	1	Ground Wire
20	1	Front Control Panel	45	1	Customer Wiring Harness
21	2	Snap Bushing	46	1	Remote Panel Harness
22	1	Start-Stop Switch	47	1	Snap Bushing
23	1	Fuel Primer Switch	48	2	Wiring Harness Clamp
24	1	15 amp Fuse	49	1	Panel Harness (Not Shown)
25	1	Fuse Holder			

# **Section 1.6- CONTROL PANEL**

---

# Section 1.7- SHEET METAL

## General

See "Exploded View of Sheet Metal" on next page. A DIVIDER PLATE (Item 1) separates the AC generator components from the engine. The engine itself is enclosed by a BASE HOUSING WRAPPER (Item 4), a FRAME (Item 24), and a BELLY PAN (Item 23). These components are sealed by means of rubber SEALS (Items 3), to prevent the escape of gases.

The LOWER FAN attaches to the engine shaft and is enclosed in a LOWER FAN HOUSING (Item 19). Air is drawn into the enclosed area around the engine and forced out of the LOWER FAN HOUSING.

Removal of sheet metal will be necessary for many repairs and for replacement of most parts.

NP-30/NP-40 Generator

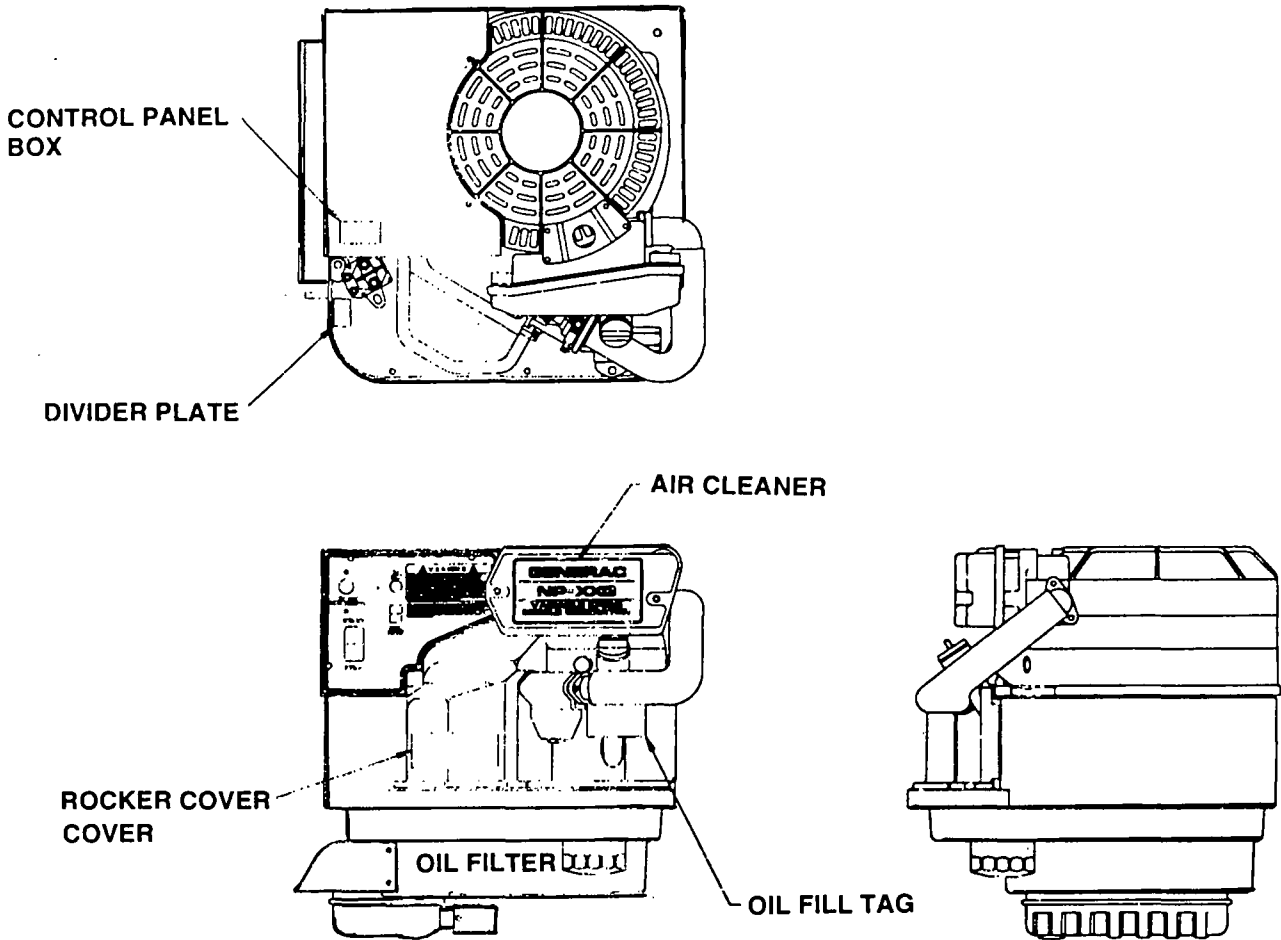

# Section 1.7- SHEET METAL

## Parts List for Exploded View of Sheet Metal

ITEM	QTY	DESCRIPTION	ITEM	QTY	DESCRIPTION
1	1	Engine-Generator Divider Plate	26	1	Grounding Strap
2	1	Engine Upper Wrapper	27	1	Fuel Pump
3	1	Rubber Seal	28	2	Barbed 90° Fitting
4	1	Base Housing Wrapper	29	3	1/4"-20 Hex Nut
5	26	M5 Screw	30	3	1/4" Lockwasher
6	2	Customer Mounting Rails	31	1	Starter Contactor
7	4	M8 Lockwasher	32	1	Starter Contactor Insulator Boot
8	4	M8-1.25 Capscrew	33	1	Oil Filter Opening Seal
9	5	M8-1.25 Capscrew	34	1	Seal Retainer
10	7	M6 Lockwasher	35	4	M8 Flatwasher
12	1	Spark Arrestor	36	1	Fuel Line
13	1	Exhaust Clamp	37	2	Hose Clamp
14	1	3/8"-16 Capscrew	38	1	Snap Bushing
15	1	3/8" Lockwasher	39	7	Lockwasher
16	1	3/8" Hex NHut	40	1	No. 8 Hex Nut
17	1	Air Outlet Deflector	41	1	No. 8 Hex Nut
18	1	Exhaust Muffler	42	2	M6-1.00 Capscrew
19	1	Lower Fan Housing	44	1	Lockwasher
20	1	Carburetor Baffle Skirt	45	1	Grounding Strap
21	1	Rocker Cover Cover	47	1	Muffler Heat Shield
22	1	Spark Plug Side Skirt	48	1	Muffler Hanger Bracket
23	1	Belly Pan	49	1	Muffler Lower Insulation
24	1	Frame	50	1	Muffler Upper Insulation
25	1	Grounding Strap			

# Section 1.7- SHEET METAL

## Exploded View of Sheet Metal

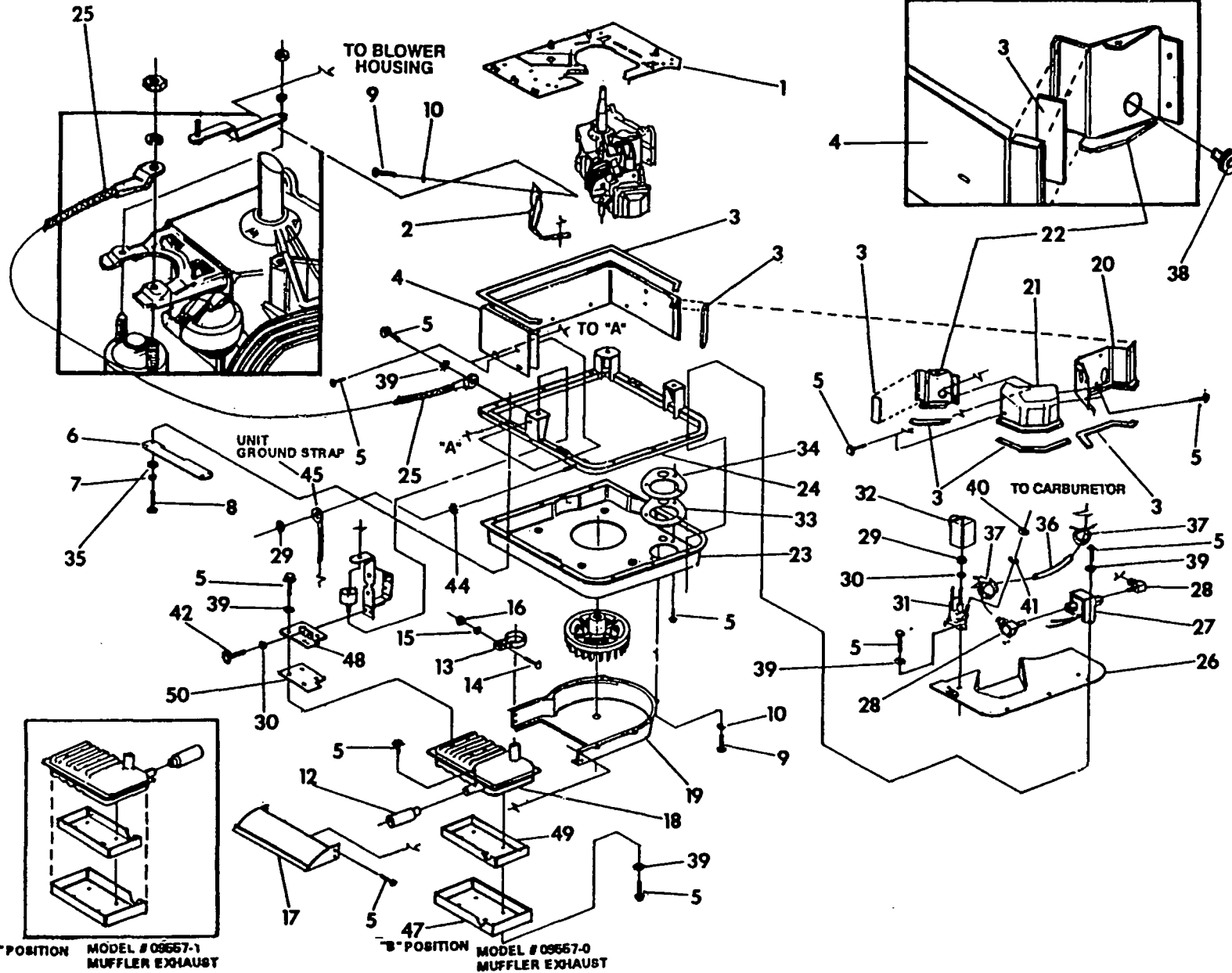

## **Section 1.7- SHEET METAL**

---



# **Part 2 ENGINE MECHANICAL**

**COMPUTER  
CONTROLLED  
VARIABLE  
SPEED RV  
GENERATORS**  
Series NP-30G and NP-40G

SECTION	TITLE
2.1	GENERAL INFORMATION
2.2	VALVE TRAIN
2.3	PISTON, RINGS, CONNECTING ROD
2.4	CRANKSHAFT & CAMSHAFT

## Section 2.1- GENERAL INFORMATION

### Introduction

The engine used on Series NP-30G and NP-40G recreational vehicle AC generators is a Generac Series GN190 or GN220, vertical shaft, single cylinder, overhead valve type.

These engines are not equipped with a mechanical engine governor. Instead, variable engine speeds are controlled by a computer circuit board. The circuit board signals a stepper motor to move the carburetor throttle linkage.

### 4-Cycle Engine Theory

#### GENERAL:

Series GN190 and GN220 engines require four (4) strokes or cycles to complete one power cycle. This is often called the "4-stroke, 5-event" cycle. The 4 strokes and 5 events that occur are (1) intake, (2) compression, (3) ignition, (4) power and (5) exhaust.

#### INTAKE STROKE (Figure 1):

The intake valve is open. The exhaust valve is closed. The piston travels downward, creating a suction which draws the air-fuel mixture from the carburetor into the cylinder and just above the piston.

#### COMPRESSION STROKE (Figure 2):

As the piston reaches bottom dead center (BDC), the intake valve closes. The exhaust valve remains closed, as well. The piston starts to move outward in the cylinder. Since both valves are closed, the air-fuel mixture in the cylinder is compressed.

#### POWER STROKE (Figure 3):

Both valves remain closed. At some point before the piston reached top dead center (TDC), the spark plug fires to ignite the fuel-air mixture. The piston moves to its top dead center position and the burning, expanding gases of combustion force the piston downward.

#### EXHAUST STROKE (Figure 4):

The expanding gases of combustion force the piston downward to its bottom dead center (BDC) position. The exhaust valve then opens, as the piston starts its movement toward top dead center (TDC). Piston movement then forces the exhaust gases out through the open exhaust valve. The 4-stroke cycle of events then starts over again.

#### TIMING:

Valve timing and ignition timing must be precisely controlled if the engine is to operate properly and efficiently. Intake and exhaust valves must open and close in a precise timed sequence if the four strokes are to occur. Ignition must occur at exactly the correct piston position, just prior to the start of the power stroke. Timing of valve opening and closing, as well as of spark occurrence, is given in relation to the piston position and the degrees of crankshaft rotation.

Ignition is timed to occur several degrees before top dead center (TDC) of the piston, to allow time for the air-fuel mixture to ignite and start to burn before the piston reaches top dead center.

There must be no leakage past the valves in their closed position or compression will not develop. Likewise, there must be no leakage past the piston.

Figure 1. Intake Stroke

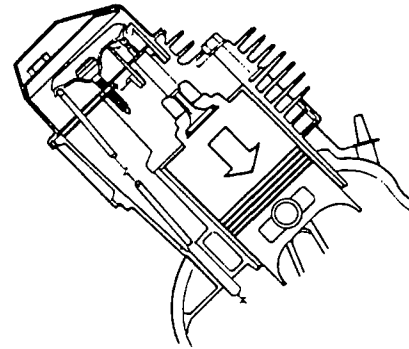

Figure 2. Compression Stroke

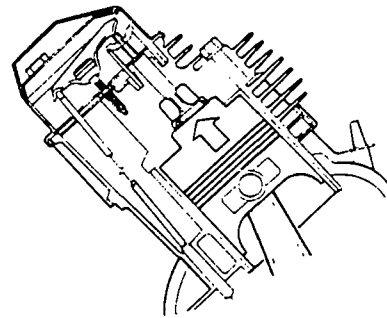

Figure 3. Power Stroke

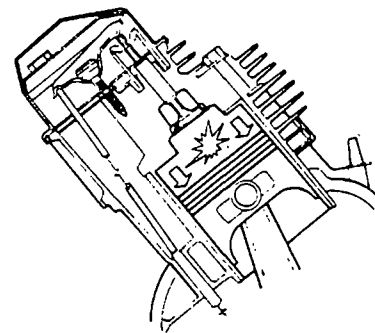
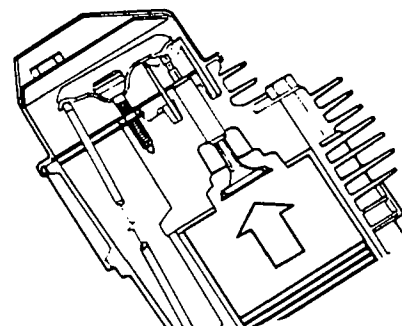

Figure 4. Exhaust Stroke



# Section 2.1- GENERAL INFORMATION

## Recommended Fuels

### GASOLINE FUEL SYSTEMS:

For models equipped with a gasoline fuel system, the use of clean, fresh, UNLEADED, regular grade gasoline is recommended. Unleaded gasoline burns cleaner, extends engine life, and promotes better starting by reducing carbon deposits in the combustion chamber.

Leaded "Regular" grade gasoline may be used if unleaded gasoline is not available.

The use of gasohol is NOT recommended. If it must be used, it should not contain more than 10 percent ethanol. When gasoline containing ethanol is used, special care is required when preparing the unit for storage (see "Storage Instructions").

DO NOT USE GASOLINE CONTAINING METHANOL.

DO NOT MIX OIL WITH THE GASOLINE.

### DANGER!

**GASOLINE IS EXTREMELY FLAMMABLE AND ITS VAPORS ARE EXPLOSIVE. DO NOT PERMIT SMOKING, OPEN FLAME, SPARKS OR ANY SOURCE OF HEAT IN THE VICINITY WHILE HANDLING GASOLINE. AVOID SPILLAGE OF GASOLINE ON A HOT ENGINE. THERE MUST BE NO LEAKAGE OF GASOLINE INTO THE RV GENERATOR COMPARTMENT.**

### GASEOUS FUEL SYSTEMS:

Some RV generator models may be equipped with an LP or natural gas fuel system. The use of such gaseous fuels may result in a slight power loss as compared to gasoline. However, that disadvantage is usually compensated for by the many advantages offered by such fuels. Some of these advantages are:

- A low residue content which results in minimum carbon formation in the engine.
- Reduced sludge buildup in the engine oil.
- Reduced burning of valves as compared to gasoline.
- No "washdown" of the engine cylinder wall during cranking and startup.
- Excellent anti-knock qualities.
- A nearly homogenous mixture in the engine cylinder.
- Fuel can be stored for long periods without breakdown.

### DANGER!

**GASEOUS FUELS ARE HIGHLY VOLATILE AND THEIR VAPORS ARE EXPLOSIVE. LP GAS IS HEAVIER THAN AIR AND WILL SETTLE IN LOW AREAS. NATURAL GAS IS LIGHTER THAN AIR AND WILL ACCUMULATE IN HIGH AREAS. EVEN THE SLIGHTEST SPARK CAN IGNITE THESE FUELS AND CAUSE AN EXPLOSION. THE USE OF LEAK DETECTORS IS RECOMMENDED WHEN GASEOUS FUELS ARE USED. ALL CODES, STANDARDS AND REGULATIONS PERTAINING TO THE INSTALLATION AND USE OF GASEOUS FUELS MUST BE COMPLIED WITH.**

## Recommended Engine Oil

Use a clean, high quality, detergent oil that is classified "For Service SC, SD, SE, SF or SG". Use no special additives with the oil.

- During summer months (above 32° F. or 0° C.), use SAE 30 oil. SAE 10W-30 oil is an acceptable substitute.
- During winter months (below 32° F. or 0° C.), use SAE 5W-20 or 5W-30 oil.
- DO NOT USE SAE 10W-40 OIL.

Engine crankcase oil capacity without oil filter change is about 29 fluid ounces (850ml).

Engine crankcase oil capacity (with oil filter change) is about 1 U.S. quart (946ml).

Change engine oil and the oil filter after the first eight (8) hours of operation. Thereafter, change engine oil and oil filter every 50 operating hours.

*NOTE: Additional information on the engine oil system can be found in Part 5 of this manual, "Engine Oil and Cooling System".*

## Storage Instructions

### PREPARATION FOR STORAGE:

The engine should be started at least once every seven (7) days and allowed to run for at least thirty (30) minutes. If this cannot be done and the engine is to remain unused longer than thirty (30) days, it must be prepared for storage. To prepare the unit for storage, proceed as follows:

1. Start the engine and let it warm up.
2. After engine is thoroughly warmed up, shut it down.

*NOTE: If the unit is equipped with a gasoline fuel system and GASOHOL was used as a fuel, turn off the supply of fuel to the engine and let it run out of gas.*

3. While engine is still warm from running, completely drain the oil. Then, refill with the recommended oil. See "Recommended Engine Oil".
4. Attach a tag to the engine indicating the viscosity and classification of the oil in the crankcase.
5. Remove the spark plug and pour about one (1) ounce (15ml) of clean, fresh engine oil into the spark plug threaded opening. Crank the engine several times to distribute the oil, then install and tighten the spark plug.
6. Remove the battery and store it in a cool, dry room on a wooden board. Never store the battery on any concrete or wood floor.
7. Clean and wipe the generator exterior surfaces.

### RETURN TO SERVICE AFTER STORAGE:

To return the unit to service after storage, proceed as follows:

1. Verify that the correct oil is in the engine crankcase by checking the tag on the engine (see "Recommended Engine Oil".) If necessary, drain oil and refill with the recommended oil.

## Section 2.1- GENERAL INFORMATION

2. Check the battery. Fill all battery cells to the proper level with distilled water. **DO NOT USE TAP WATER IN THE BATTERY.** If necessary, recharge the battery to a 100 percent state of charge or replace it, if defective.
3. Turn OFF all electrical loads. Start the engine at no-load and let it warm up.
4. Apply electrical loads to at least 50% of the unit's rated capacity.
5. When engine is thoroughly warmed up, turn off or disconnect all electrical loads. Then, shut the engine down.

THE UNIT IS NOW READY FOR SERVICE.

### *Engine Tuneup*

The following procedure may be used as a minor tuneup. On completion of the procedure, the engine should run properly. If it does not run properly, additional checks and repairs are required.

1. Service and repair engine air cleaners, as necessary.
2. Check engine oil level and condition of oil. Add or change oil as required.
3. Remove shrouding and clean away dirt from the engine cylinder head and cooling fins.
4. Check fuel filters and clean or replace as necessary.
5. Replace the spark plug with a Champion RC12YC (or equivalent) plug.
  - a. Set spark plug gap to 0.030 inch (0.76mm).
  - b. Install new plug and tighten to 13 foot-pounds (1.8 N-m).
  - c. If a torque wrench is not available, tighten spark plug as tight as possible with fingers and then
    - (1) If plug is RE-USED, tighten about 1/4 turn more with a wrench.
    - (2) If plug is NEW, tighten it about 1/2 turn more with a wrench.
6. Check that wiring is free of breaks, abrasions and are properly routed.
7. Check for spark as outlined in "Ignition" section of Part 6 of this manual.
8. Run engine, adjust carburetor if necessary and check operation.

# Section 2.1- GENERAL INFORMATION

## Exploded View of Engine Long Block

ITEM	QTY	DESCRIPTION	ITEM	QTY	DESCRIPTION
1	1	Connecting Rod & Cap	31	2	Valve Spring
2	1	Piston Pin	32	1	Dowel Pin
3	1	Piston Ring Set (STD)	33	1	Inner Oil Pump Rotor
4	2	1/4" Pipe Plug	34	2	Connecting Rod Bolt
5	1	Breather Cover	36	1	Cylinder Head (see NOTE 1)
6	1	Piston	37	1	Exhaust Valve
7	2	Piston Pin Retainer	38	1	Intake Valve
8	1	Crankshaft & Gear Assembly	39	2	Push Rod
10	1	Oil Breather Separator	40	2	Tappet
11	1	Crankcase Assembly	41	1	Oil Pickup Screen
12	1	Sleeve Bearing	42	1	Rocker Cover Gasket
13	2	Crankshaft Oil Seal	43	2	Pivot Ball Stud
14	1	Breather Baffle Cup	44	2	Rocker Arm
15	4	M6 Screw	45	2	Rocker Arm Nut
16	4	Lockwasher	46	1	Puch Rod Guide Plate
17	3	Dowel Sleeve	47	5	Head Bolt
18	1	Camshaft Assembly	48	1	Rocker Cover
19	1	Crank Case Flange Gasket	49	2	Breather Gasket
21	1	Cylinder Head Gasket	50	2	Bolt
22	1	Oil Pressure Spring Retainer	51	1	Outer Oil Pump Rotor
23	1	Oil Pressure Spring	52	1	Oil Sump Assembly
24	1	Oil Pressure Relief Valve Ball	53	2	Valve Spring Wear Washer
25	1	Thread Forming Bolt	54	1	Intake Valve Seal
26	4	M6 Screw & Lockwasher	55	1	Oil Temperature Switch
27	1	Oil Filter Adapter	56	2	M3 Screw
28	6	M8-1.25 Capscrew	57	2	M3 Lockwasher
29	1	Oil Pressure Switch	58	1	Spark Plug (see NOTE 2)
30	2	Valve Spring Retainer	59	1	Oil Filter Adapter Gasket
			60	1	1/4" NPT Pipe Plug

NOTE 1:- Item 36 Includes valve seats and guides.

NOTE 2:- Use a Champion RC12YC (or equivalent) spark plug with gap set to 0.030 inch (0.76mm).

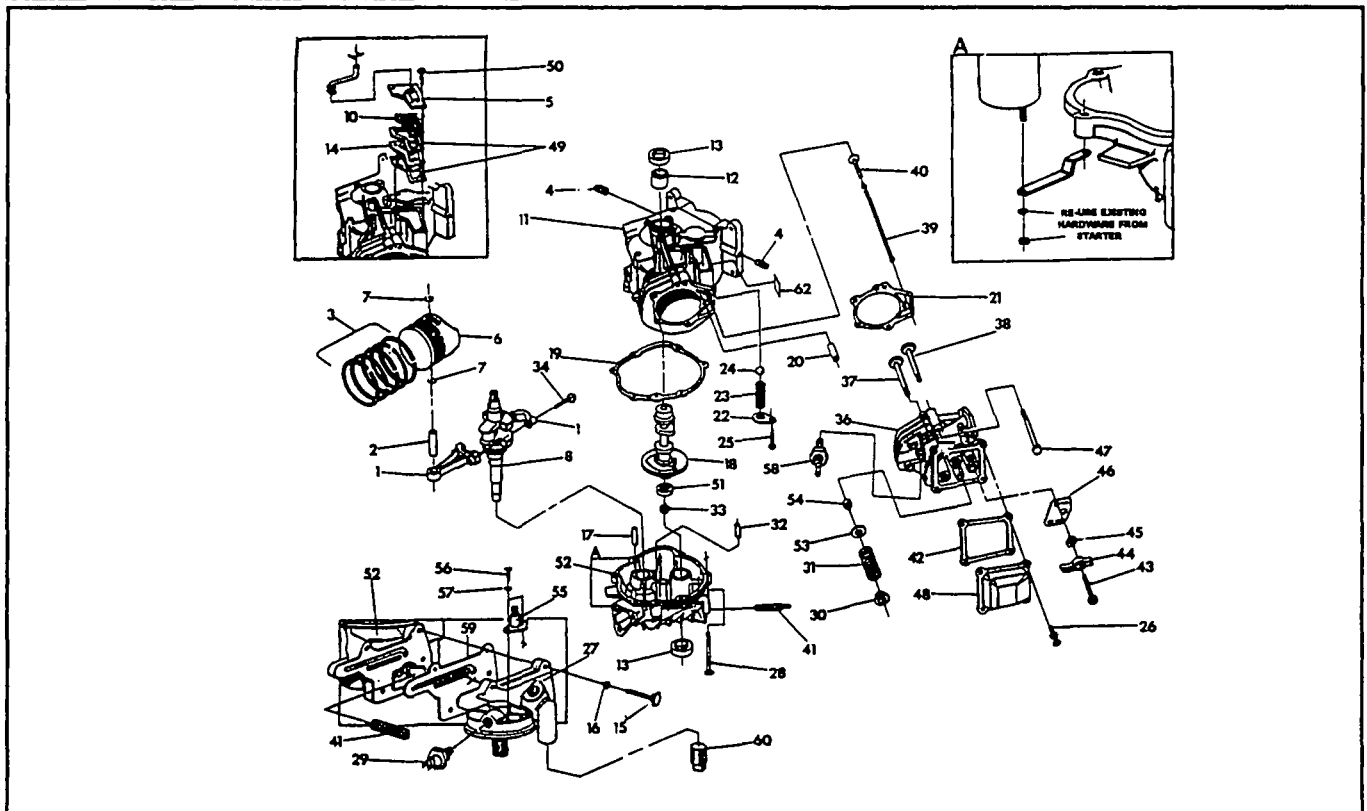

## Section 2.2- VALVE TRAIN

### Valve Train Components

Valve train components are listed below and shown in Figure 1, below.

ITEM	QTY	DESCRIPTION
1	2	Tappet
2	2	Push Rod
3	2	Rocker Arm
4	2	Pivot Ball Stud
5	2	Rocker Arm Jam Nut
6	1	Push Rod Guide Plate
7	2	Valve Spring
8	2	Valve Spring Retainer
9	2	Valve Spring Washer
10	1	Exhaust Valve
11	1	Intake Valve

Figure 1. Valve Train Components

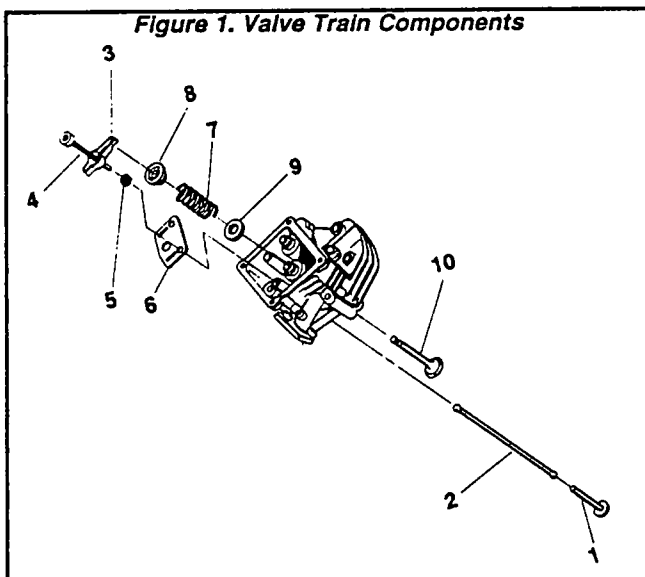

### Valve Components Removal

1. The **ROCKER ARM COVER** is retained by four M6-1.00 x 12mm screws and lockwashers. Remove the four screws and lockwashers, then remove the **ROCKER ARM COVER** and its gasket.

**NOTE:** Replace the **ROCKER ARM COVER GASKET** each time the **COVER** is removed, to ensure proper sealing.

Figure 2. Removal of Rocker Arm Cover

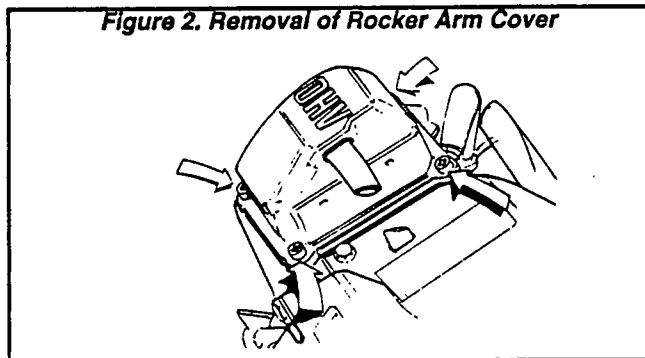

2. Loosen the rocker arm jam nuts on the pivot ball studs. Then, loosen the pivot ball studs. Remove the two pivot ball studs, the rocker arms and the jam nuts. Also remove the push rod guide plate.

**NOTE:** Keep the Intake valve and exhaust valve parts separated. Intake and exhaust parts are identical. However, once a wear pattern has been established on these parts their fit will be different.

Figure 3. Rocker Arm, Push Rod & Guide Plate

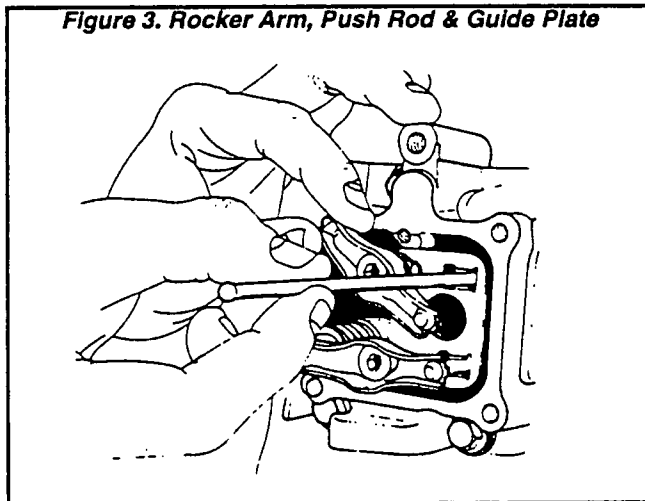

3. Remove the push rods.

4. Remove the cylinder head bolts, then remove the cylinder head and head gasket.

**NOTE:** Replace the head gasket every time the head is removed. The new head gasket must be free of nicks and scratches as these could cause leakage.

Figure 4. Cylinder Head Removal

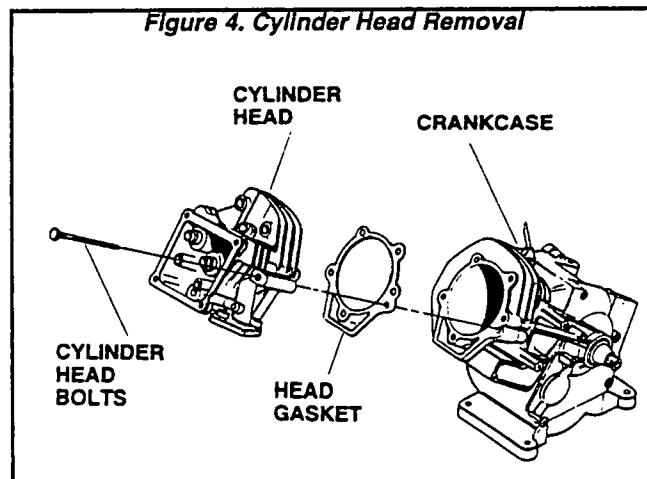

### DANGER!

**ALWAYS WEAR SAFETY GLASSES WHEN REMOVING THE VALVE SPRINGS.**

5. See Figure 5, next page. Hold the valve with your fingers while compressing the spring with your thumb, then proceed as follows:

## Section 2.2- VALVE TRAIN

### Valve Components Removal (Continued)

- While the spring is compressed, slide the larger hole of the valve spring retainer toward the valve stem.
- With the larger spring retainer hole around the valve stem, release the spring.
- Remove the valve spring retainer, the spring and the spring washer.

Figure 5. Removal of Valve Spring

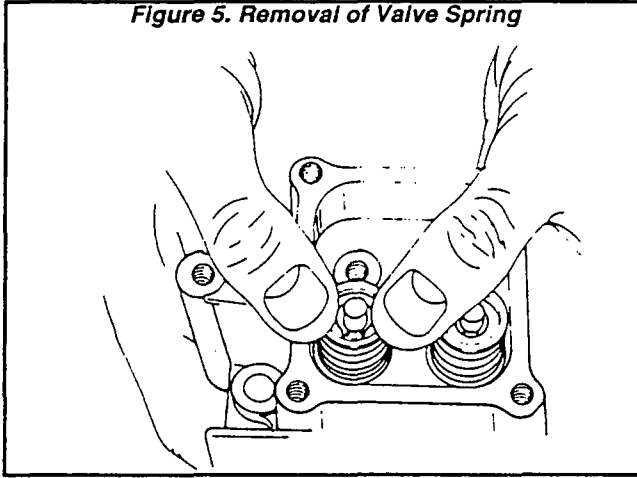

- Remove the intake and exhaust valves.
- Clean all parts. Remove carbon from valve heads and stems.
- Inspect the valves and valve seats. Service parts as outlined under "Valve Service".

### Valve Service

#### VALVES:

Replace valves if they are damaged, distorted or if the margin is ground to less than 0.039 inch (1.0mm). If the valves are in useable condition, use a valve grinder to grind the faces to a 45° angle. Check valve stem diameter.

After the valves have been reconditioned, they should be lapped with a suitable lapping tool and valve lapping compound.

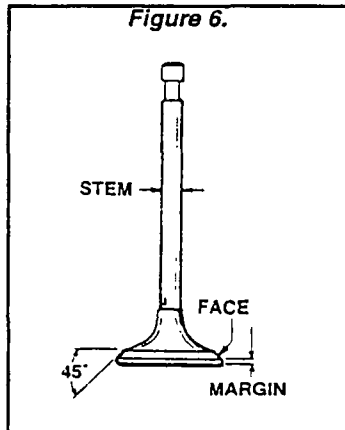

**NOTE:** Proper lapping of valves and valve seats will remove grinding marks and ensure a good seal between the valve and its seat. Be sure to clean lapping compound from the valve seats and faces.

**VALVE MARGIN (GN190)**  
**DESIGN MARGIN:** 0.058-0.060 inch (1.48-1.52mm)  
**WEAR LIMIT:** 0.039 inch (0.98mm) Maximum

**VALVE MARGIN (GN220)**  
**DESIGN MARGIN:** 0.034-0.044 inch (0.87-1.13mm)  
**WEAR LIMIT:** 0.020 inch (0.50mm) Maximum

**INTAKE VALVE STEM DIAMETER (GN190)**  
**DESIGN DIAMETER:** 0.215-0.216 inch (5.465-5.480mm)  
**WEAR LIMIT:** 0.214 inch (5.435mm) Minimum

**INTAKE VALVE STEM DIAMETER (GN220)**  
**DESIGN DIAMETER:** 0.274-0.275 inch (6.965-6.980mm)  
**WEAR LIMIT:** 0.273 inch (6.934mm) Minimum

**EXHAUST VALVE STEM DIAMETER (GN190)**  
**DESIGN DIAMETER:** 0.214-0.215 inch (5.445-5.460mm)  
**WEAR LIMIT:** 0.213 inch (5.415mm) Minimum

**EXHAUST VALVE STEM DIAMETER (GN220)**  
**DESIGN DIAMETER:** 0.273-0.274 inch (6.945-6.960mm)  
**WEAR LIMIT:** 0.272 inch (6.909mm) Minimum

**NOTE:** Design sizes and wear limits of valve train components can also be found in Part 9 of this Manual ("SPECIFICATIONS & CHARTS").

#### VALVE SEATS:

Valve seats are NOT replaceable. If burned or pitted, seats can be reground. Grind seats at a 45° angle and to a width of 0.039 inch (1.0mm).

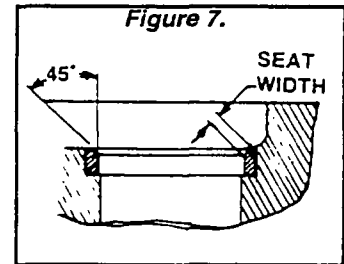

**VALVE SEAT WIDTH (GN190 & GN220)**  
**DESIGN WIDTH:** 0.034-0.044 inch (0.87-1.13mm)  
**WEAR LIMIT:** 0.064 inch (1.63mm) Maximum

#### VALVE GUIDES:

Valve guides are permanently installed in the cylinder head and cannot be replaced. If the guides become worn beyond the wear limit, they can be reamed to accommodate a 0.020 inch (0.50mm) oversize valve stem. Use a straight shank hand reamer or a low speed drill press to ream valve guides.

**VALVE GUIDES (GN190)**  
**DESIGN DIAMETER:** 0.216-0.217 inch (5.505-5.520mm)  
**WEAR LIMIT:** 0.218 inch (5.54mm) Maximum

**VALVE GUIDES (GN220)**  
**DESIGN DIAMETER:** 0.237-0.2364 inch (6.02-6.005mm)  
**WEAR LIMIT:** 0.238 inch (6.045mm) Maximum

**NOTE:** After the valve guides have been oversized, be sure to recut the valve seats so they will align with the guides.

## Section 2.2- VALVE TRAIN

### Valve Service (Continued)

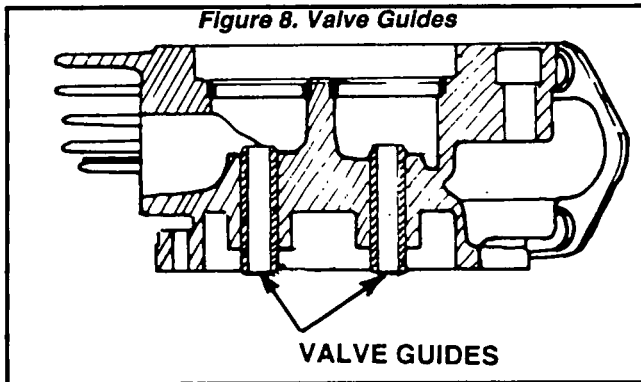

#### VALVE TAPPETS:

Valve tappets can be removed during removal of the engine camshaft. Intake and exhaust valve tappets are identical. However, once a wear pattern has been established the two tappets should not be interchanged.

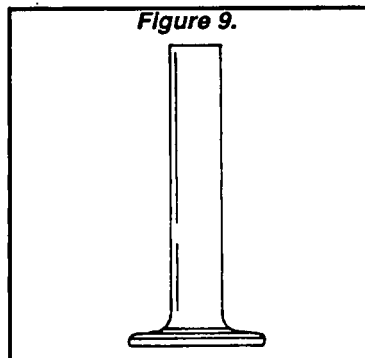

#### VALVE SPRINGS:

Inspect the valve springs. Measure the spring free length. Also, check the amount of force required to compress the spring to a length of 1.39 inch (35.2 mm). Replace any damaged or defective spring.

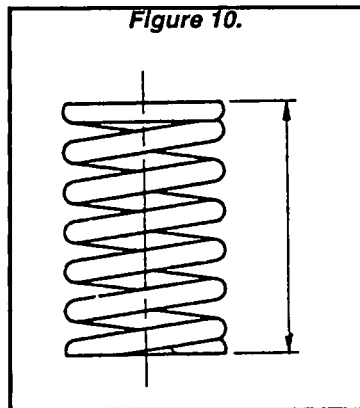

**VALVE SPRING FREE LENGTH**  
GN190: 1.910 inch (48.48mm)  
GN220: 2.074 inch (52.69mm)

**FORCE REQUIRED TO COMPRESS SPRING TO 1.39 INCH (35.2MM)**  
GN190: 14.8-16.2 lbs (6.7-7.4kg)  
GN220: 19.8-21.8 lbs (9.0-9.9kg)

### Valve Components Installation

After the valve train parts have been inspected and (if necessary) serviced, install them as follows:

1. Lubricate the valve stems and the valve guides with engine oil.
2. Install the intake and exhaust valves through their respective valve guides in the cylinder head.
  - a. The exhaust valve has the smaller head with a diameter of 1.053 inches (26.75mm).
  - b. The intake valve has the larger head, having a diameter of 1.171 inches (29.75mm).
  - c. Valve seat sizes in the cylinder head will match their respective head sizes.

**NOTE:** The exhaust valve stem is also smaller than that of the intake valve.

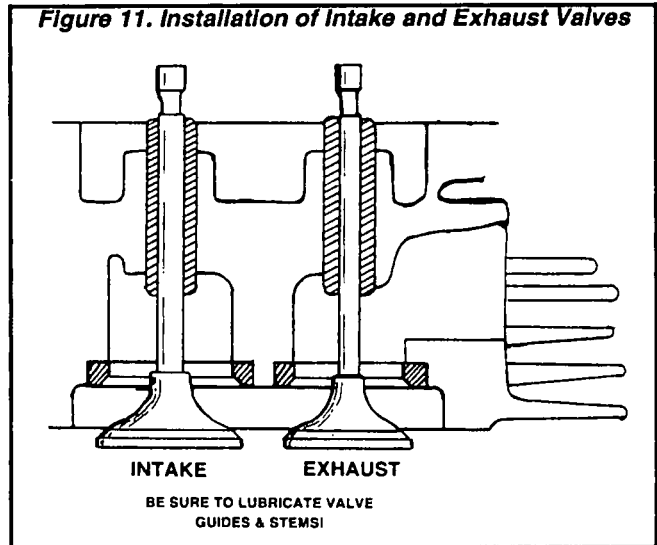

3. Install the valve spring washers, valve springs and valve spring retainers over the valve guides.
  - a. Hold the valve with your fingers and use your thumbs to compress the spring.
  - b. When the spring is compressed sufficiently, slide the spring retainer small opening over the valve stem.
  - c. With the smaller retainer opening around the valve stem, release the spring.

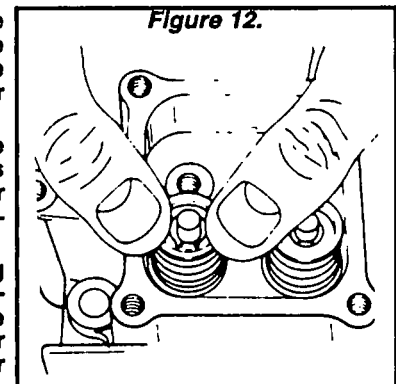

4. After both valves have been retained in the cylinder head, position a new head gasket and install the cylinder head.

**NOTE:** The head gasket is coated with a special substance for better sealing. The gasket must be free of nicks, scratches and other defects for better sealing.

5. Install cylinder head bolts. Tighten the head bolts in the sequence shown to the recommended tightness.



## Section 2.2- VALVE TRAIN

### Valve Components Installation (Continued)

**TIGHTENING TORQUE  
CYLINDER HEAD**  
GN190: 25 foot-pounds  
GN220: 29 foot-pounds

Figure 13. Head Bolts Tightening Sequence

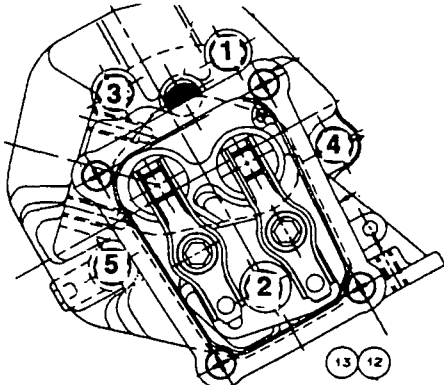

TORQUE SEQUENCE= 1-2-3-4-5

6. Place the push rod guide plate into position on the head. Then, install the rocker arm and the pivot ball stud. The rocker arm jam nut must be on far enough to hold the guide plate in position.

**NOTE: Do NOT adjust valve clearance at this time. This will be done later.**

Figure 14. Install Rocker Arm & Pivot Ball Stud

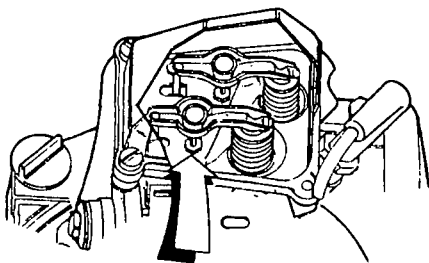

7. Install the push rod with either end against the tappet.  
a. Place the push rod between the guide plate tabs.  
b. Place the rocker arm socket onto end of push rod.  
c. Alignment is correct when push rod ball rests in the rocker arm socket.

**NOTE: The pivot ball stud will be tightened when the valve clearance is adjusted. After valve clearance has been adjusted, the rocker arm cover will be installed.**

Figure 15. Push Rod Installation

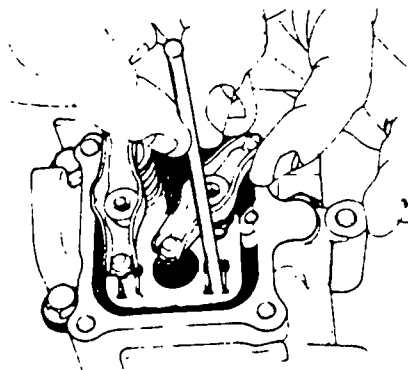

### Adjusting Valve Clearance

When adjusting valve clearance, the engine should be at room temperature and the piston should be at top dead center (TDC) of its compression stroke (both valves closed).

#### VALVE CLEARANCE GN190 ENGINE

INTAKE VALVE: 0.001-0.003 inch (0.03-0.07mm)  
EXHAUST VALVE: 0.001-0.003 inch (0.03-0.07mm)

#### VALVE CLEARANCE GN220 ENGINE

INTAKE VALVE: 0.001-0.0022 inch (0.03-0.056mm)  
EXHAUST VALVE: 0.0018-0.003 inch (0.046-0.07mm)

Adjust the valve clearance as follows:

1. Rotate the crankshaft until the piston is at top dead center (TDC) of its compression stroke. Both valves should be closed.
2. Loosen the rocker arm jam nut.
3. Use an allen wrench to turn the pivot ball stud while checking the clearance between the rocker arm and the valve stem with a feeler gauge.

Figure 16. Adjusting Valve Clearance

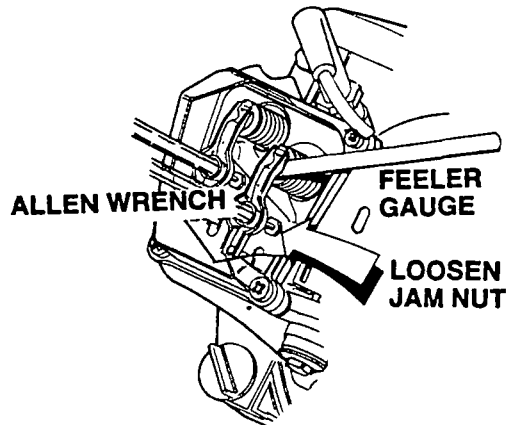

## Section 2.2- VALVE TRAIN

4. When valve clearance is correct, hold the pivot ball stud with the allen wrench while tightening the rocker arm jam nut with a crow's foot. Tighten the jam nut to the specified torque. After tightening the jam nut, recheck the valve clearance to make sure it did not change.

**JAM NUT TIGHTENING TORQUE**  
GN190: 75 inch-pounds  
GN220: 6.3 foot-pounds

*Figure 17. Tightening Pivot Ball Jam Nut*

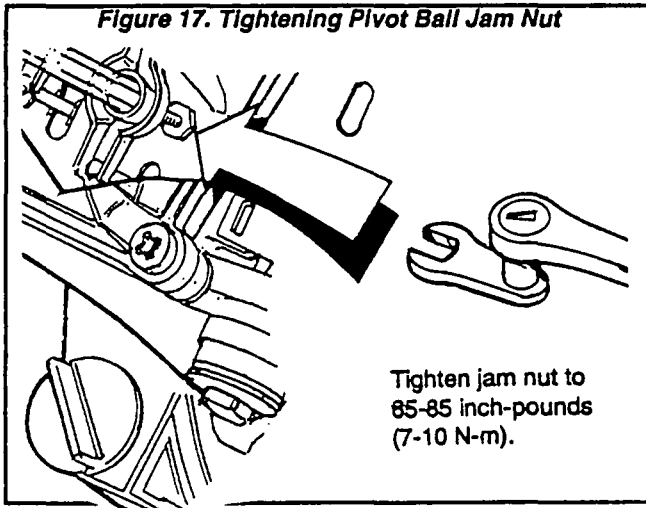

### *Rocker Arm Cover Installation*

Place a new rocker arm cover gasket into place. Then, install the rocker arm cover. Finally, retain the cover with M6-1.00 x 12mm screws.

*Figure 18. Rocker Arm Cover Installation*

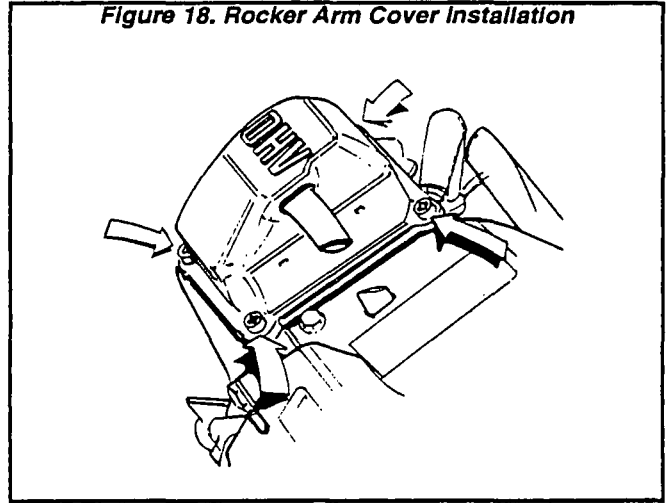

## **Section 2.2- VALVE TRAIN**

---

# Section 2.3- PISTON, RINGS, CONNECTING ROD

## Oversize Piston & Rings

Worn or scored cylinders may be rebored to 0.010 (0.25mm) or 0.020 (0.50mm) oversize. Pistons and piston rings of matching oversize are available to fit the rebored cylinder.

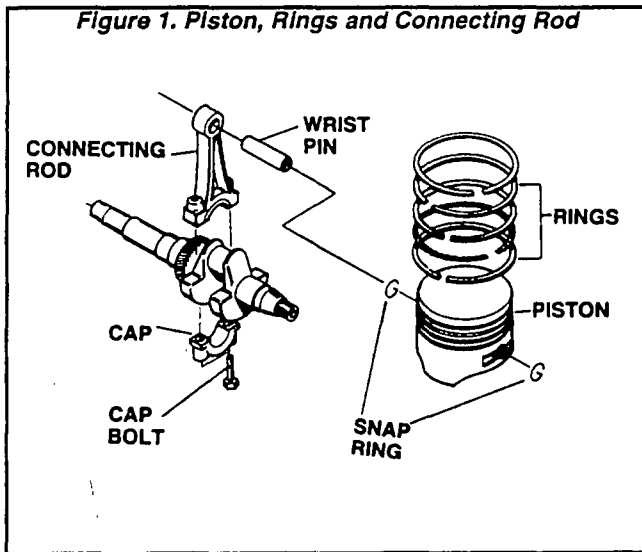

Figure 1. Piston, Rings and Connecting Rod

## CHECK FOR PISTON WEAR:

The piston is slightly elliptical. It's smaller diameter is in line with the wrist pin boss. It's larger diameter is 90° from the wrist pin boss.

**NOTE:** An assembly mark is provided on the piston. This mark should face the flywheel end of the crankshaft (3:00 position) during reassembly.

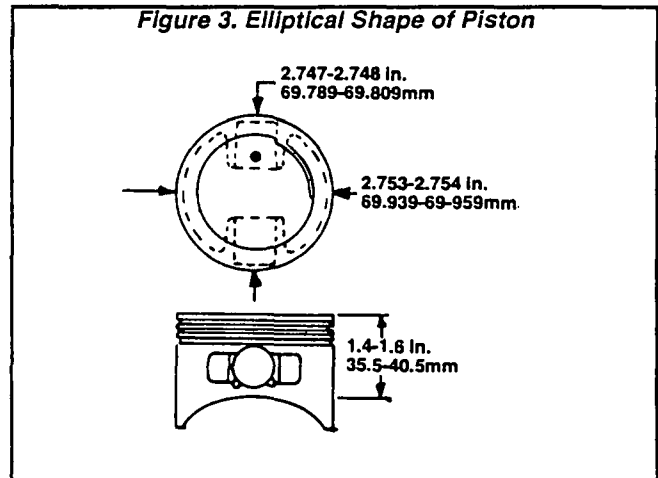

Figure 3. Elliptical Shape of Piston

## Prior to Removal

Before removing pistons, rings and connecting rod, clean all carbon from the cylinder bore. Carbon buildup in the cylinder bore can cause ring breakage during piston removal.

## Removal

Remove the connecting rod CAP BOLTS and the connecting rod CAP. Then, push the piston and connecting rod out through top of cylinder.

## Piston

### REMOVE FROM CONNECTING ROD:

**NOTE:** An oil hole in the wrist pin area of the piston helps distribute oil to assist in cooling. The oil hole also provides an assist in removing the wrist pin snap ring.

To remove the piston from the connecting rod, proceed as follows:

1. Move the snap ring around until its protruding end is aligned with the notched out oil hole. Use needle nose pliers to turn the snap ring and pull it toward you.
2. With one snap ring removed, slide the wrist pin out of the piston boss. This will separate the piston from the connecting rod.

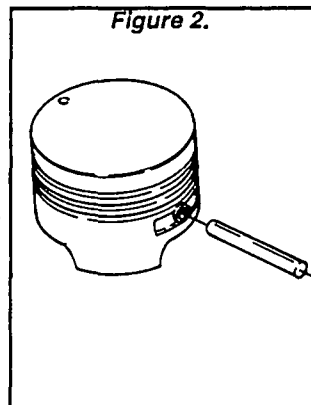

Figure 2.

To check the piston for wear, proceed as follows:

1. Minor Diameter:- At a position directly in line with the wrist pin hole, measure from top of piston down to a distance of 1.4-1.6 inches (35.5-40.5mm). This is the "minor" diameter. Measure at this point to check for wear.

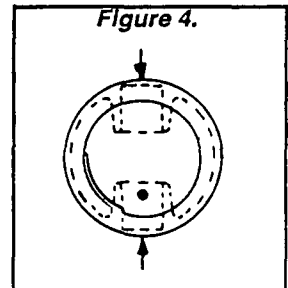

Figure 4.

**PISTON MINOR DIAMETER (GN190 & GN220)**  
**DESIGN DIAMETER: 2.747-2.748 inch (69.789-69.809mm)**  
**WEAR LIMIT: 2.745 inch (69.739mm) Minimum**

2. Major Diameter:- At a point 90° from the wrist pin bore, measure down 1.4-1.6 inches (35.5-40.5mm). This is the "major" diameter. Measure at this point to check for piston wear. Replace the piston if wear limits are exceeded.

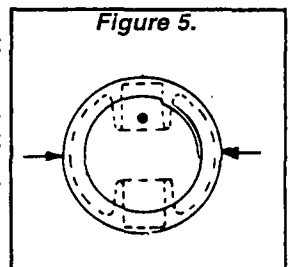

Figure 5.

3. Check wrist Pin for Looseness:- A rough check for wear in the wrist pin, wrist pin bore in the piston, or wrist pin bore in the connecting rod is to check for looseness or play with the piston assembled to the rod. Looseness or play indicates a worn wrist pin, or a worn bore in the piston or connecting rod.

**NOTE:** Always apply engine oil to wrist pin and its bores during installation. Wrist pin fit is very close.

# Section 2.3- PISTON, RINGS, CONNECTING ROD

## Piston (Continued)

### CHECK PISTON FOR WEAR (CONT'D):

4. Check Wrist Pin for Wear:- Measure the outside diameter of the wrist pin. Also measure the inside diameter of the wrist pin bore in the piston and in the connecting rod. Also check wrist pin length. Replace any component that is worn excessively.

**WRIST PIN OUTSIDE DIAMETER (GN190 & GN220)**  
**DESIGN DIAMETER: 0.708-0.709 inch (17.989-18.000mm)**  
**WEAR LIMIT: 0.707 inch (17.969mm) Minimum**

**WRIST PIN LENGTH (GN190 & GN220)**  
**DESIGN LENGTH: 2.196-2.213 inch (55.8-56.2mm)**  
**WEAR LIMIT: 2.193 inch (55.7mm) Minimum**

**WRIST PIN BORE IN PISTON (GN190 & GN220)**  
**DESIGN DIAMETER: 0.708-0.709 inch (18.000-18.011mm)**  
**WEAR LIMIT: 0.710 inch (18.026mm) Maximum**

**CONNECTING ROD SMALL END I.D. (GN190 & GN220)**  
**DESIGN DIAMETER: 0.709-0.710 inch (18.02-18.03mm)**  
**WEAR LIMIT: 0.711 inch (18.05mm) Maximum**

5. Ring to Groove Side Clearance:- Clean carbon from piston ring grooves. Install new rings. Use a feeler gauge to measure the side clearance between the rings and ring grooves. If ring-to-groove side clearance exceeds the stated limits, replace the piston.

**RING TO GROOVE SIDE CLEARANCE (GN190 & GN220)**  
**0.0004-0.0014 inch (0.012-0.034mm)**

Figure 6. Ring to Groove Side Clearance

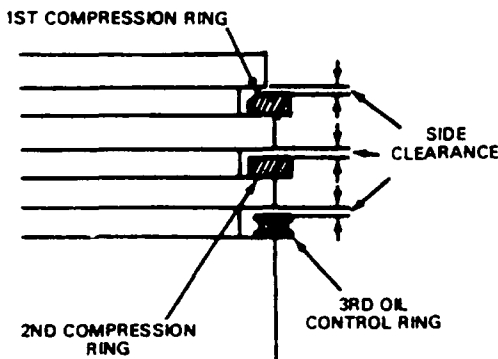

## Piston Rings

### GENERAL:

The following rules pertaining to piston rings must always be complied with:

- Always replace piston rings in sets.
- When removing rings, use a ring expander to prevent breakage. Do not spread the rings too far or they will break.
- When installing the piston into the cylinder, use a ring compressor. This will prevent ring breakage and/or cylinder damage.
- When installing new rings, deglaze the cylinder wall with a commercially available deglazing tool.

### RING DESCRIPTION:

A piston ring SET consists of (a) a top compression ring, (b) a second compression ring, and (c) an oil ring assembly. When installing rings, pay close attention to the following:

- The OIL RING is a 3-piece assembly which consists of two oil rails and an oil spacer ring. Oil rails have a rounded face and can be installed with either side up.
- The second compression ring has an inside chamfer which must face UP when installing the ring.
- The top compression ring has a barrel-shaped face and can be installed with either side up.

Figure 7. Ring Locations in Piston Grooves

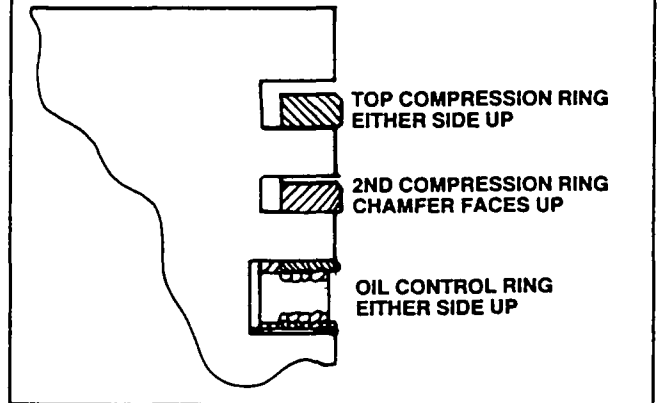

### CHECKING PISTON RING END GAP:

To check piston rings end gap, proceed as follows (see Figure 8):

1. Locate a point inside the cylinder that is 2.75 inches (70mm) down from top of cylinder. This is approximately half-way down.
2. Place the ring into the cylinder. Use the piston to push the ring squarely into the cylinder to the proper depth.
3. Use a feeler gauge to measure the ring end gap. If end gap is excessive, rebore the cylinder to take oversize parts.

**TOP RING END GAP (GN190 & GN220)**  
**DESIGN GAP: 0.005-0.016 inch (0.15-0.40mm)**  
**WEAR LIMIT: 0.024 inch (0.60mm) Maximum**

## Section 2.3- PISTON, RINGS, CONNECTING ROD

**SECOND RING END GAP (GN190 & GN220)**  
DESIGN GAP: 0.006-0.016 inch (0.15-0.40mm)  
WEAR LIMIT: 0.024 inch (0.60mm) Maximum

**OIL RING END GAP (GN190 & GN220)**  
DESIGN GAP: 0.015-0.055 inch (0.38-1.40mm)  
WEAR LIMIT: 0.062 inch (1.60mm) Maximum

Figure 8. Ring End Gap

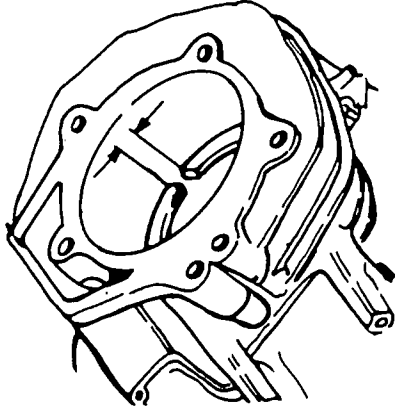

### Connecting Rod

The connecting rod is manufactured of die cast aluminum. Alignment marks are provided on the rod and on the connecting rod cap. Be sure to align these marks when assembling the rod to the crankshaft. Connecting rod bolts are of the "washerless" type.

The connecting rod and the connecting rod cap are a matched set and must be replaced as a matched set.

Figure 9.

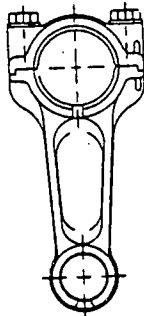

### Assembly and Installation

#### ASSEMBLY:

Use a ring expander when installing rings into the piston ring grooves. Install the OIL RING ASSEMBLY first. Then, install the second compression ring with its inside chamfer facing up. Finally, install the top compression ring.

When assembling the piston, connecting rod and wrist pin, the assembly marks on the piston must be toward the flywheel side of the engine.

Coat the wrist pin, wrist pin bore in piston, and wrist pin bore in the rod with engine oil. Install one snap ring into the piston's wrist pin bore. Then, assemble the piston to the rod. Slide the wrist pin through one piston bore, through the rod bore, and through the second piston bore until it contacts the snap ring. Then, install the second snap ring into the piston bore.

#### INSTALLATION:

Coat the cylinder walls with engine oil, as well as the crank throw, connecting rod bearing and connecting rod cap bearing. Then, install the rod and piston assembly as follows:

1. Use a ring compressor to compress the rings into the piston ring grooves. **MAKE SURE ALL RINGS ARE FULLY COMPRESSED INTO THEIR GROOVES.**
2. Guide the connecting rod into the cylinder, with assembly mark on piston toward the flywheel side of engine.
3. When the ring compressor contacts top of cylinder, use a wood hammer handle to gently tap the piston down into the cylinder.
4. Check that the connecting rod's large diameter bearing is coated with oil, as well as the crank throw and the connecting rod cap.
5. Guide the large end of the connecting rod onto the crankshaft. Install the connecting rod cap. The match mark on the cap must be aligned with an identical mark on the rod (Figure 10).
6. Install the connecting rod cap bolts and tighten to the proper torque.

**TIGHTENING TORQUE**  
**CONNECTING ROD CAP BOLTS (GN190 & GN220)**  
10 foot-pounds (1.36 N-m)

**NOTE:** The connecting rod can be installed in either direction. That is, the cap marks on the rod and cap may face toward the installer or away from the installer. The only requirement is that the assembly mark on top of piston be toward the flywheel side of engine.

Figure 10. Match Marks on Rod and Cap

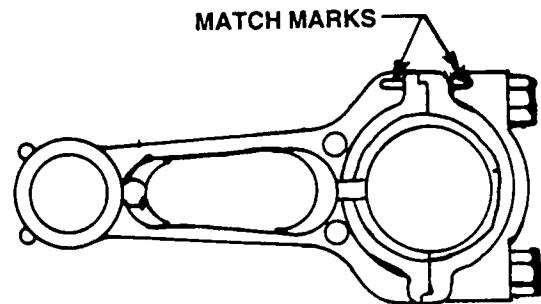

### Cylinder Service

#### INSPECTION:

Check the cylinder for dirty, broken or cracked fins. Also look for worn or scored bearings, or a scored cylinder wall. Check the cylinder head mounting surface for warpage. If the head is warped, it must be replaced. If the cylinder bore is worn (as evidenced by excessive ring end gap), the cylinder should be replaced or rebored to 0.010 or 0.020 (0.25 or 0.50mm) oversize.

After reboring the cylinder to a specific oversize, install an identically oversize piston along with identically oversized rings.

## Section 2.3- PISTON, RINGS, CONNECTING ROD

---

### *Cylinder Service (Continued)*

#### **REBORING THE CYLINDER:**

Always resize the cylinder bore to EXACTLY 0.010 inch or 0.020 inch (0.25 or 0.50mm) over the standard cylinder dimensions. If this is done accurately, the service oversize ring and piston will fit and correct clearances will be maintained.

<b>STANDARD CYLINDER BORE DIAMETER</b> <b>MINIMUM: 2.7560 inches (70.000mm)</b> <b>MAXIMUM: 2.7570 inches (70.025mm)</b>
--

To rebores the cylinder, use a commercial hone of suitable size chucked in a drill press having a spindle speed of about 600 rpm. Use the stones and lubrication recommended by the hone manufacturer to produce the proper cylinder bore finish. Proceed as follows:

1. Start with coarse stones. Center the cylinder under the drill press spindle. Lower the hone so that the lowest end of the stone contacts the lowest point in the cylinder bore.
2. Begin honing at bottom of cylinder. Move the hone up or down at about 50 strokes per minute, to avoid cutting ridges in the cylinder wall. Every fourth or fifth stroke, move the hone far enough to extend it one (1) inch beyond the top and bottom of the cylinder bore.
3. Every 30 or 40 strokes, check the bore for size and straightness. If stones collect metal, clean them with a wire brush.
4. Hone with coarse stones until the cylinder bore is within 0.002 inch (0.05mm) of the desired finish size. Then, replace the coarse stones with burnishing stones and continue until bore is within 0.0005 inch (0.01mm) of the desired size.
5. Install finishing stones and polish the cylinder to its final size.
6. Clean the cylinder with soap and water. Dry thoroughly.
7. Replace the piston and rings with parts of correct oversize.

# Section 2.4- CRANKSHAFT AND CAMSHAFT

## General

Prior to removal of the crankcase cover, gain access to the engine and generator by removing surrounding sheet metal as required. See Section 1.6.

### Crankcase Cover Removal

Before attempting to remove the crankcase cover, remove rust, paint and burrs from the power takeoff (PTO) end of the crankshaft. This will reduce the possibility of damaging the oil seal in the crankcase cover or the bearing during cover removal.

To remove the crankcase cover, proceed as follows:

1. Drain oil from the crankcase.
2. Remove the engine cylinder head, push rods and push rod guide plate. See Section 2.2.
3. Remove all bolts that retain the crankcase cover to the crankcase.
4. Remove the crankcase cover. If necessary, tap lightly with a soft hammer on alternate sides of the cover.

Figure 1. Crankcase Cover Removal

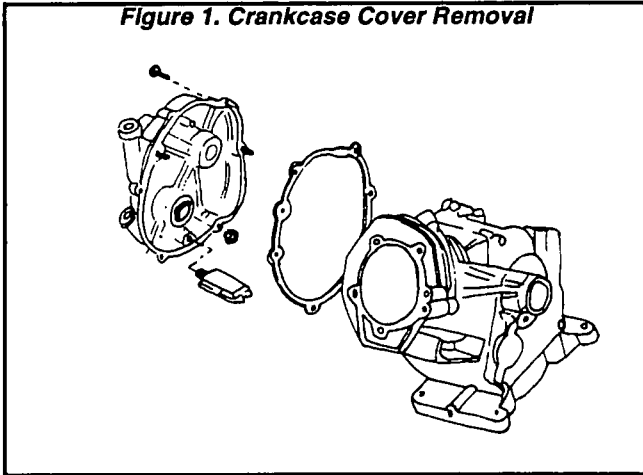

Figure 2. Camshaft Removal

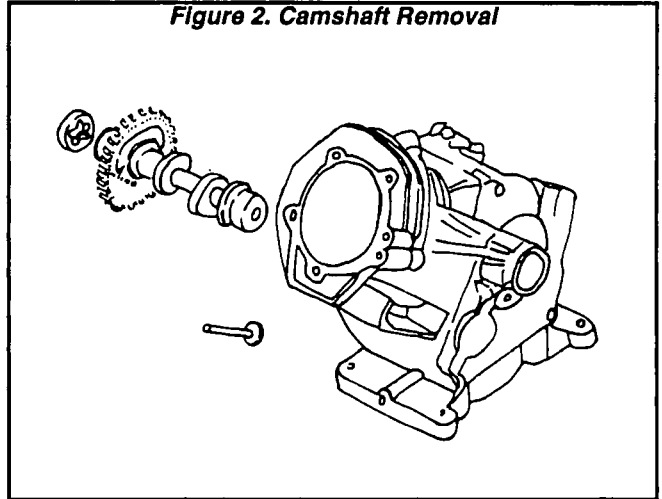
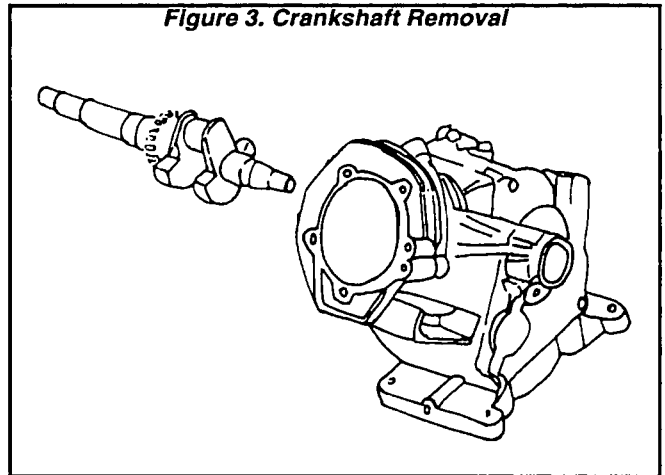

Figure 3. Crankshaft Removal



### Camshaft Removal

See Figure 2. Remove the camshaft as follows:

1. Tip the engine over onto the flywheel end of the crankshaft. Support the engine to prevent end of crankshaft from resting on the workbench.
2. Reach in with two fingers and hold the tappets up so they are clear of the camshaft lobes. Then, remove the camshaft.
3. Remove the two tappets.
4. Remove the outer and inner oil pump rotors.

### Crankshaft Removal

See Figure 3. To remove the crankshaft, proceed as follows:

1. The engine flywheel must be removed before the crankshaft can be removed.
2. The piston and connecting rod must be removed.
3. Remove the crankshaft by pulling it straight out of the crankcase.

### Camshaft Inspection

Carefully inspect the entire camshaft for wear, nicks, damage. All areas indicated in Figure 4 should be checked for wear.

Figure 4. Points to Check on Camshaft

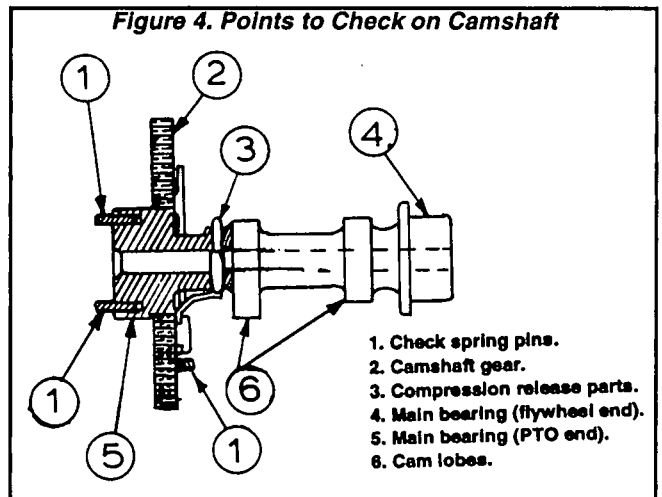

1. Check spring pins.
2. Camshaft gear.
3. Compression release parts.
4. Main bearing (flywheel end).
5. Main bearing (PTO end).
6. Cam lobes.



## Section 2.4- CRANKSHAFT AND CAMSHAFT

### Camshaft Inspection (Continued)

The following should be measured carefully to check for wear:

**MAIN CAMSHAFT BEARING DIAMETER (FLYWHEEL END)**  
 DESIGN DIAMETER: 1.022-1.023 inch (25.96-25.98mm)  
 WEAR LIMIT: 1.020 inch (25.91mm) Minimum

**MAIN CAMSHAFT BEARING DIAMETER (PTO END) GN-190 ONLY**  
 DESIGN DIAMETER: 1.022-1.023 inch (25.96-25.98mm)  
 WEAR LIMIT: 1.020 inch (25.91mm) Minimum

**MAIN CAMSHAFT BEARING DIAMETER (PTO END) GN-220 ONLY**  
 DESIGN DIAMETER: 1.297-1.298 inch (32.96-32.98mm)  
 WEAR LIMIT: 1.295 inch (32.89mm) Minimum

**CAMSHAFT BEARING BORE IN CRANKCASE**  
 DESIGN DIAMETER: 1.024-1.025 inch (26.00-26.03mm)  
 WEAR LIMIT: 1.026 inch (26.06mm) Maximum

**CAMSHAFT BEARING BORE IN CRANKCASE COVER**  
 DESIGN DIAMETER: 1.299-1.300 inch (33.00-33.03mm)  
 WEAR LIMIT: 1.302 inch (33.06mm) Maximum

**CAM LIFT**  
 DESIGN LIFT: 0.210-0.212 inch (5.34-5.38mm)  
 WEAR LIMIT: 0.206 inch (5.24mm) Minimum

### Crankshaft Inspection:

#### CRANKSHAFT PROPER:

Use a commercial solvent to clean the crankshaft. After cleaning, inspect the crankshaft as follows:

- Inspect keyways in crankshaft, make sure they are not worn or spread. Remove burrs from edges of keyway, to prevent scratching the bearing.
- Inspect timing gear teeth for chipping or cracking. If the timing gear is damaged, the crankshaft assembly must be replaced.
- Inspect the crankpin for damage, nicks, scratches, etc. Small nicks and scratches may be polished out using fine emery cloth. **ALL EMERY RESIDUE MUST BE REMOVED.** Use a solvent (such as kerosene) to remove emery residue.
- Carefully measure the outside diameter (O.D.) of the crankpin, crankshaft journal at flywheel end, and crankshaft journal at PTO end. Replace the crankshaft if it is worn smaller than the stated limits.

**NOTE: DO NOT regrind the crankpin to any smaller diameter. Undersize connecting rods are NOT available for the GN-190 or GN-220 engines.**

- Inspect oil passage. Use a length of wire to make sure it is open. Inspect threaded ends of crankshaft.

**CRANKPIN OUTSIDE DIAMETER**  
 DESIGN DIAMETER: 1.180-1.181 INCH (29.99-30.01MM)  
 WEAR LIMIT: 1.179 inch (29.96mm) Minimum

**CRANKSHAFT BEARING JOURNAL (FLYWHEEL END)**  
 DESIGN DIAMETER: 1.102-1.103 inch (28.000-28.012mm)  
 WEAR LIMIT: 1.100 inch (27.95mm) Minimum

**CRANKSHAFT BEARING JOURNAL (PTO END)**  
 DESIGN DIAMETER: 1.102-1.103 inch (28.000-28.012mm)  
 WEAR LIMIT: 1.186 inch (27.95mm) Minimum

Figure 5. Points to Check on Crankshaft

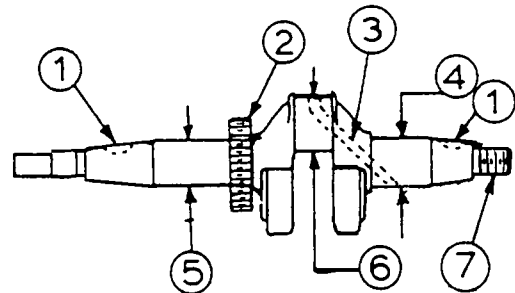

1. Check keyways.
2. Crankshaft gear.
3. Oil passage.
4. Journal (flywheel end).
5. Journal (PTO end).
6. Crankpin.
7. Threaded ends.

#### CRANKSHAFT SLEEVE BEARING:

A sleeve bearing (Figure 6) is pressed into the crankshaft bore of the crankcase. A bearing is NOT provided for the crankshaft bore in the crankcase cover.

Inspect the sleeve bearing in the crankcase for damage. Measure the inside diameter (I.D.) of the sleeve bearing. Replace any sleeve bearing that is worn excessively. Press out the old bearing, press a new bearing into place.

**CRANKSHAFT SLEEVE BEARING**  
 DESIGN DIAMETER: 1.104-1.106 inch (28.044-28.099mm)  
 WEAR LIMIT: 1.107 inch (28.129mm) Maximum

Check the crankshaft bearing bore in the crankcase cover. If limits are exceeded, replace the crankcase cover.

**CRANKSHAFT BEARING BORE IN CRANKCASE COVER**  
 DESIGN DIAMETER: 1.104-1.105 inch (28.040-28.065mm)  
 WEAR LIMIT: 1.106 inch (28.092mm) Maximum

## Section 2.4- CRANKSHAFT AND CAMSHAFT

Figure 6. Sleeve Bearing in Crankcase

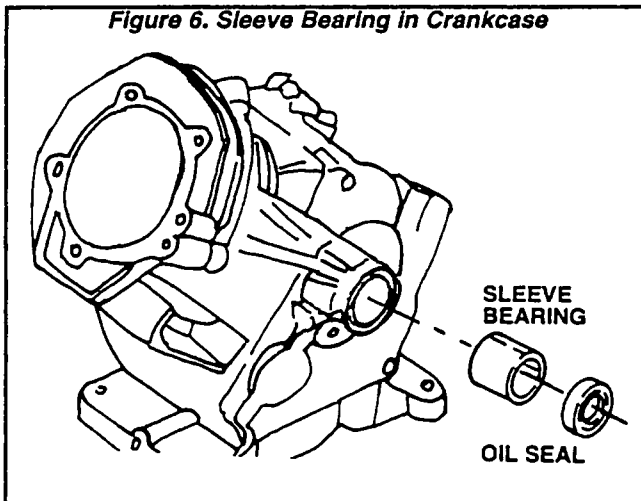

Figure 8. Compression Release Mechanism on Camshaft

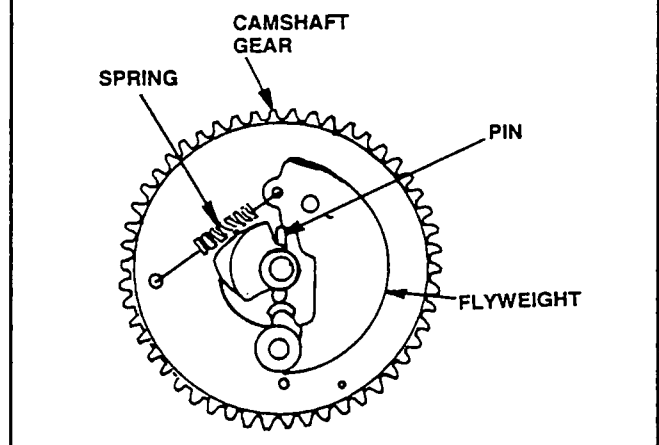

Figure 7. Bearing Bore in Crankcase Cover

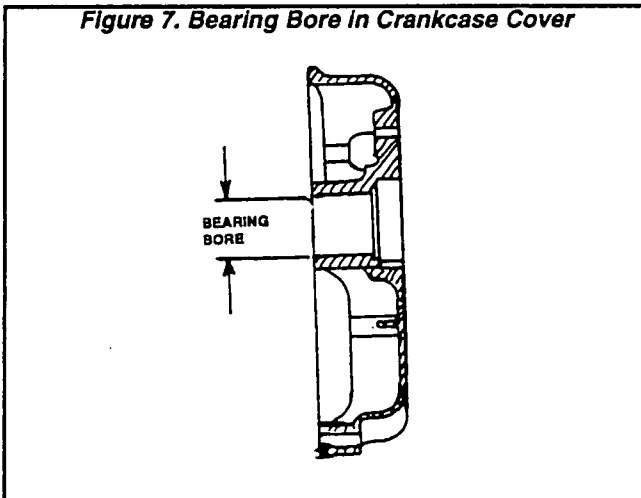
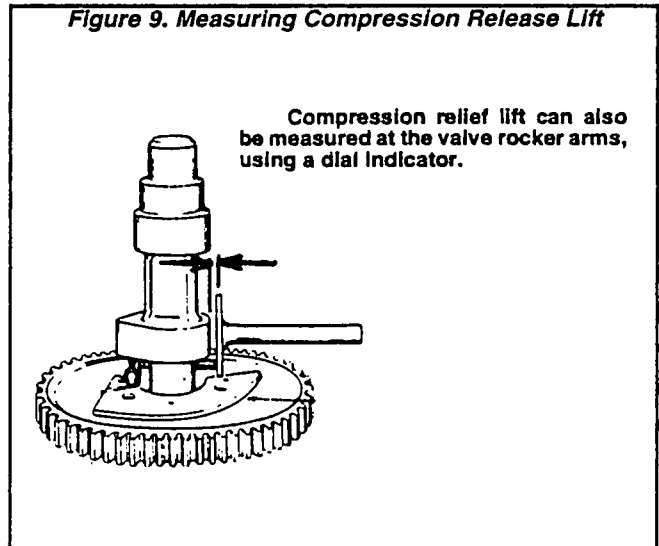

Figure 9. Measuring Compression Release Lift



### Compression Release Mechanism

A mechanical compression release is provided on the camshaft. See Figure 8. A PIN extends over the cam lobe. This PIN pushes on the tappet, to lift the valve and relieve compression for easier cranking. When the engine starts, centrifugal force moves the FLYWEIGHT outward against SPRING force. The PIN will then drop back and allow the engine to run at full compression.

Measure the amount of compression release lift at the tappet (Figure 9).

**COMPRESSION RELEASE LIFT FOR GN-190 ENGINE  
(MEASURED AT TAPPET)**  
DESIGN LIFT: 0.027-0.055 Inch (0.70-1.40mm)  
WEAR LIMIT: 0.023 Inch (0.60mm) Minimum

**COMPRESSION RELEASE LIFT FOR GN-220 ENGINE  
(MEASURED AT TAPPET)**  
DESIGN LIFT: 0.020-0.047 inch (0.50-1.20mm)  
WEAR LIMIT: 0.016 Inch (0.406mm) Minimum

### Installing the Crankshaft

Before installing the crankshaft, lubricate all bearing surfaces with engine oil. Use oil seal protectors, to prevent damage to seals during installation. Install the crankshaft as follows:

1. Lubricate all bearing surfaces with engine oil.
2. Install the valve tappets.
3. Support both ends of the crankshaft and carefully install into the crankcase.
4. Rotate the crankshaft until the timing mark (Figure 10) is toward the cam gear side of the crankcase.

### Installing the Camshaft

Apply engine oil to the camshaft main bearing and to bearing bore in crankcase. Carefully install the camshaft into the crankcase camshaft bore.

Hold the tappets out of the way during installation. Align timing mark on camshaft gear with timing mark on crankshaft gear (piston will be at top dead center). See Figure 11.

## Section 2.4- CRANKSHAFT AND CAMSHAFT

### Installing the Camshaft (Continued)

**NOTE:** For installation of the oil pump assembly, oil pickup assembly and crankcase cover, see Part 5 "ENGINE OIL & COOLING SYSTEM".

Figure 10. Timing Mark on Crankshaft Gear

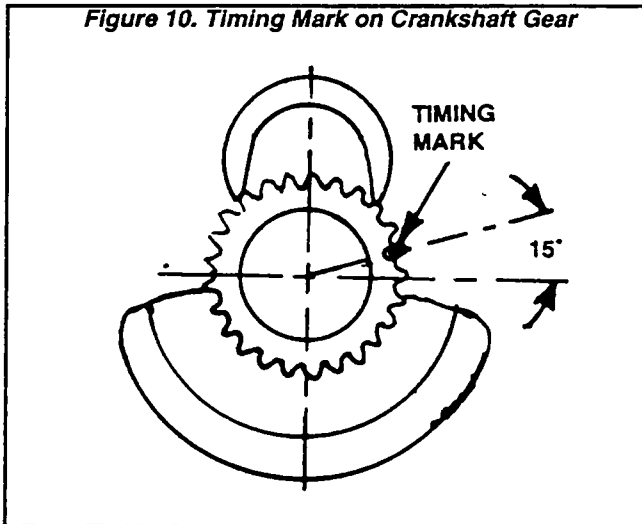
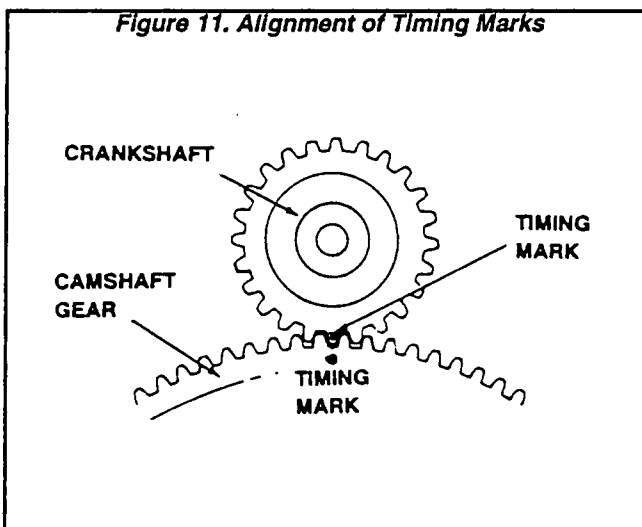

Figure 11. Alignment of Timing Marks



# Part 3 GASOLINE FUEL SYSTEM

**COMPUTER  
CONTROLLED  
VARIABLE  
SPEED RV  
GENERATORS**  
Series NP-30G and NP-40G

SECTION	TITLE
3.1	INTRODUCTION TO FUEL SYSTEM
3.2	AIR CLEANER & AIR INTAKE
3.3	FILTER & FUEL PUMP
3.4	CARBURETOR
3.5	AUTOMATIC CHOKE
3.6	SPEED CONTROL SYSTEM

# Section 3.1- INTRODUCTION TO FUEL SYSTEM

## General

Recreational vehicle generators equipped with a gasoline fuel system are usually installed so that they share the fuel supply tank with the vehicle engine. When this is done, the generator installer must never tee off the vehicle fuel supply line to deliver fuel to the generator.

When the generator fuel supply line is teed off the vehicle's fuel supply line, the more powerful vehicle engine's fuel pump will starve the generator when both are running. In addition, when the vehicle engine is not running the generator fuel pump will draw all of the gasoline from the vehicle engine line or even from the vehicle engine carburetor. This will result in hard starting of the vehicle engine.

One method of sharing the same fuel supply tank is to install a special fitting at the tank outlet so that two fuel dip tubes can be fitted in the tank (Figure 1). Another method is to install a new outlet in the tank. If the tank has an unused outlet, it can be used.

A second fuel dip tube can be installed in the original tank outlet if the tank outlet is large enough to accommodate two dip tubes. The required fittings can be made at a machine shop. To install a second fuel outlet on the tank means removing the tank to braze or weld a new fitting into place.

not contain more than 10% ethanol and it must be removed from the generator fuel system during storage. do NOT use fuel containing methanol. If any fuel containing alcohol is used, the system must be inspected more frequently for leakage and other abnormalities.

Figure 1. Sharing a Fuel Supply Tank

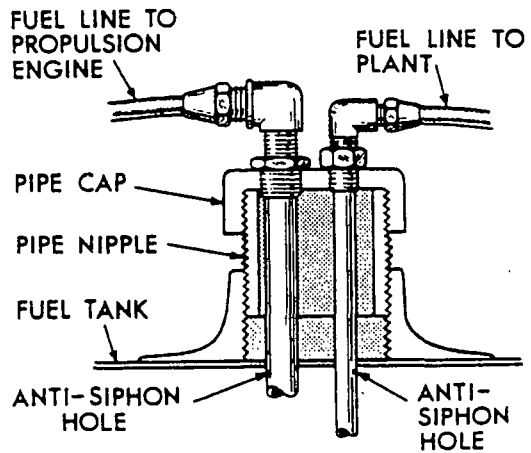

### DANGER!

ATTEMPTING TO WELD OR BRAZE ON A FUEL TANK, EMPTY OR NOT, IS EXTREMELY DANGEROUS. FUEL VAPORS IN THE TANK WILL RESULT IN AN EXPLOSION.

The generator's fuel dip tube in the tank should be shorter than the vehicle engine's dip tube. This will prevent the generator from consuming the entire fuel supply.

### DANGER!

THE FUEL SYSTEM DESIGNED AND INSTALLED BY THE GENERATOR MANUFACTURER IS IN STRICT COMPLIANCE WITH STANDARDS ESTABLISHED BY THE RECREATIONAL VEHICLE INDUSTRY ASSOCIATION (RVIA). NOTHING MUST BE DONE DURING MAINTENANCE THAT WILL RENDER THE SYSTEM IN NON-COMPLIANCE WITH THOSE STANDARDS.

### DANGER!

THERE MUST BE NO LEAKAGE OF GASOLINE OR GASOLINE VAPORS INTO THE VEHICLE. THE GENERATOR COMPARTMENT MUST BE VAPOR-TIGHT TO PREVENT ENTRY OF FUEL VAPORS OR FUMES INTO THE VEHICLE. THE GENERATOR'S VENTILATION SYSTEM MUST PROVIDE A FLOW OF AIR THAT WILL EXPEL ANY FUEL VAPOR ACCUMULATIONS.

## Recommended Fuel

Use a high quality UNLEADED gasoline. Leaded REGULAR grade gasoline is an acceptable substitute.

Do NOT use any fuel containing alcohol, such as "gasohol". If gasoline containing alcohol is used, it must

## Evaporation Control Systems

Federal and state laws have imposed strict evaporative controls on gasoline fuel systems. The recreational vehicle industry has complied with such strict regulations by using specially designed fuel tanks, tank filler tubes and gas caps. Special canisters are often used to collect the gasoline vapors rather than let them escape into the atmosphere.

Such systems are designed to operate within very critical pressure ranges. For that reason, the vehicle manufacturer's fuel supply system design must not be altered. Service technicians working on the RV generator systems must not do anything that might change the vehicle fuel system design.

Figure 2. Typical Gasoline Fuel System

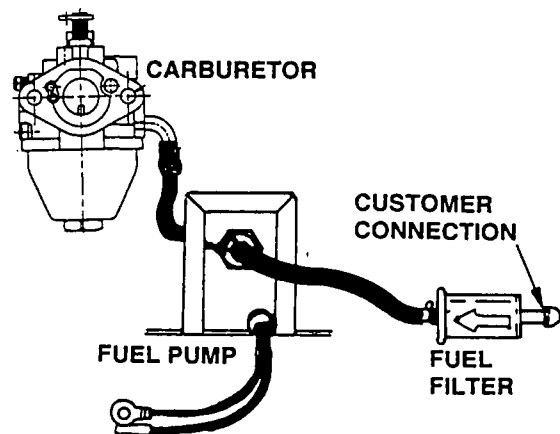

**Section 3.1- INTRODUCTION TO FUEL SYSTEM**

---

## Section 3.2- AIR CLEANER & AIR INTAKE

### Air Cleaner

#### DESCRIPTION:

The air cleaner assembly consists of (a) an air cleaner BASE, (b) a PAPER FILTER, and (c) a COVER. See Figure 1.

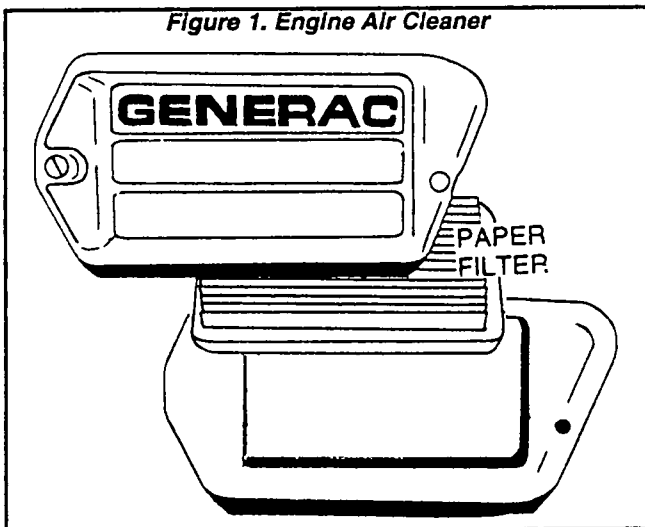

Figure 1. Engine Air Cleaner

#### SERVICING THE AIR CLEANER:

Clean or replace the PAPER FILTER every 25 hours of operation or once each year, whichever comes first.

1. Loosen the two screws that retain the air cleaner COVER and remove the COVER.
2. Remove the PAPER FILTER.
3. Clean the PAPER FILTER by tapping gently on a flat surface. If PAPER FILTER is extremely dirty, replace it.
4. Clean the air cleaner BASE and COVER, then install the new PAPER FILTER into COVER.
5. Install COVER with PAPER FILTER. Retain to BASE with two screws.

### Air Intake

See Figure 2. Air is drawn into the aircleaner, passes through the air cleaner filter, and is then ported to the carburetor air inlet through an air intake hose.

Periodically inspect the air intake hose for condition, damage, holes, perforations, etc. Replace hose, if necessary. Inspect air intake hose clamps for tightness, condition. Tighten or replace as necessary.

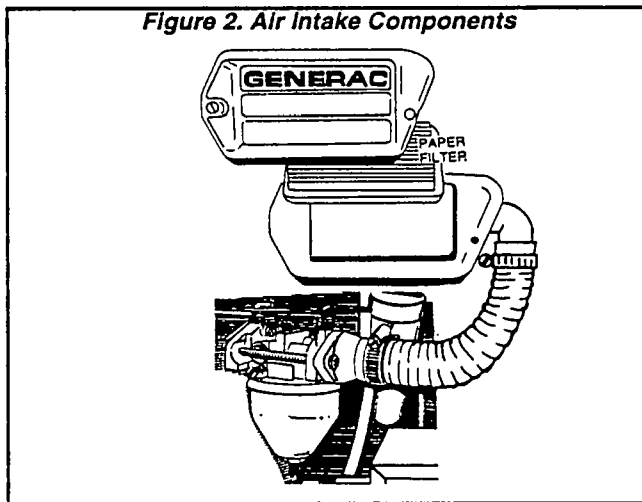

Figure 2. Air Intake Components

## **Section 3.2- AIR CLEANER & AIR INTAKE**

---



## Section 3.3- FILTER & FUEL PUMP

### Fuel Filter

The fuel filter should be removed and replaced every 100 hours of operation or once each year, whichever occurs first.

Figure 1. Fuel Filter (Typical)

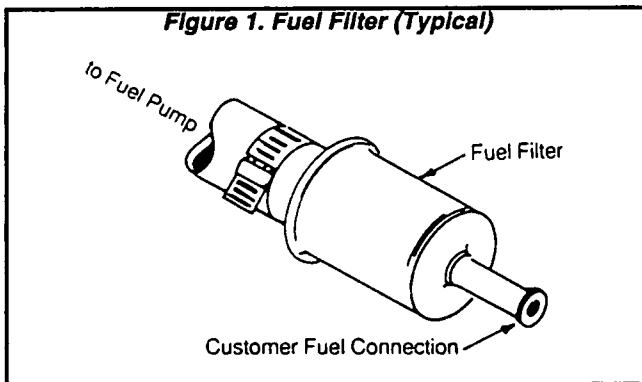

### Fuel Pump

#### DESCRIPTION:

The 12 volts DC electric fuel pump has a zinc plate finish. Flow through the pump is positively shut off when it is not operating. The pump is actually rated at a voltage of 8 to 16 VDC, but has a nominal voltage rating of 12 VDC.

Current draw of the pump at nominal voltage is approximately 1.4 amperes maximum.

Pressure rating of the pump at zero delivery is 2.0 to 3.5 psi.

Two wires are brought out from the pump. The black wire is grounded by connecting it to a pump mounting bolt. The red wire is identified as Wire No. 14A. The pump will operate whenever:

- The FUEL PRIME switch on the generator panel is actuated to its "ON" position.
- During engine startup and running conditions when the Engine Controller circuit board energizes the Wire No. 14 circuit.

Figure 2. Electric Fuel Pump

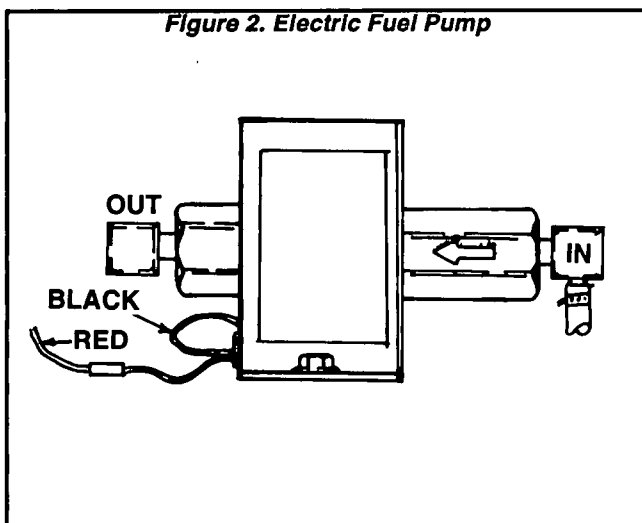

#### TESTING THE PUMP:

1. The pump coil can be tested for an open or shorted condition as follows:

a. Test for "Open":

- (1) Disconnect the RED pump wire at its "bullet" lug.
- (2) Set a VOM to its "Rx1" scale and zero the meter.
- (3) Connect one meter test probe to the RED pump wire, the other test probe to terminal end of the pump's BLACK lead. The VOM should indicate pump coil resistance.

**FUEL PUMP NOMINAL COIL RESISTANCE  
ABOUT 0.75 to 1.00 ohm**

b. Test for "Shorted" condition:

- (1) Disconnect the RED and the BLACK fuel pump leads.
- (2) Set a VOM to its "Rx10,000" or "Rx1K" scale and zero the meter.
- (3) Connect one VOM test lead to the pump RED lead, the other test probe to the pump body. The meter should read "Infinity".

2. Pump operation can be tested as follows:

- a. Disconnect the fuel line from the outlet side of the fuel pump.
- b. Make sure a supply of fuel is available to the inlet side of the pump.
- c. The RED lead from the pump must be connected properly into the circuit. The pump's BLACK lead must be connected at the pump mounting bolt.
- d. Actuate the Fuel Prime switch on the generator panel. The pump should operate and should pump fuel from the outlet side.

**NOTE: If desired, a pressure gauge can be attached to the pump's outlet side. Pump outlet pressure should be 2.0 to 3.5 psi.**

## **Section 3.3- FILTER AND FUEL PUMP**

---

## Section 3.4- CARBURETOR

### General Information

Proper engine performance depends on the carburetion system. The use of clean, fresh gasoline and a well-maintained air cleaner are extremely important to proper operation, as well as engine reliability and power.

Most causes of carburetion problems are related to the use of stale, gummy fuel and the ingestion of dirt. Before servicing the carburetor, be sure to check for evidence of these conditions. Gasoline that is left in the fuel lines for long periods can form gum or varnish deposits that will adversely affect carburetor operation.

**NOTE:** A commercial fuel stabilizer (such as STABIL®) will minimize the formation of gum deposits during storage. Add the stabilizer to the gasoline in the fuel tank or in the storage container. Follow the ratio recommended on the stabilizer container. Run the engine for about 10 minutes after adding stabilizer, to allow it to enter the carburetor. "STABIL®" is a brand name fuel stabilizer that can be purchased in most automotive repair facilities or in lawn and garden centers.

### Description

The carburetor used on GN-190 and GN-220 engines is a float type with fixed main jet. Carburetor throttle position and engine speed are controlled by an electric stepper motor. The stepper motor moves the throttle in response to signals received from a CCG circuit board. The circuit board senses load voltage, establishes the correct engine speed to obtain correct voltage and delivers an output signal to the stepper motor. The stepper motor adjusts the engine throttle to change engine speed and establish correct output voltage.

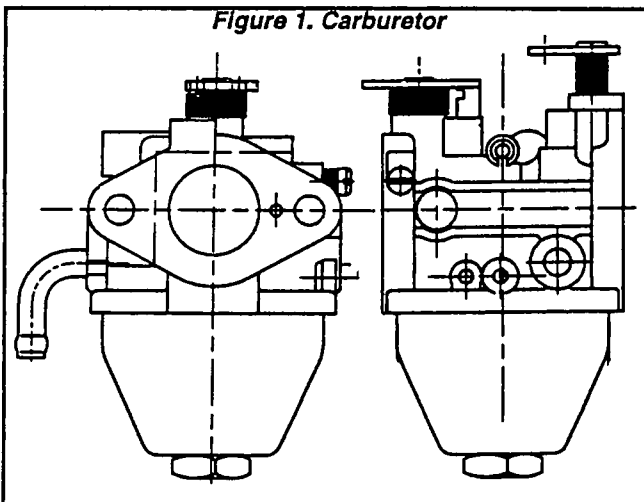

### Carburetor Operation

#### FLOAT OPERATION:

A hollow plastic float maintains fuel level in the float bowl. As fuel is used, the float moves downward to move an inlet needle valve off its seat.

When the needle valve moves off its seat, fuel can flow into the bowl. As the fuel level rises, the float moves upward to force the needle valve against its seat and stop the flow into the bowl.

Figure 2. Carburetor Sectional View

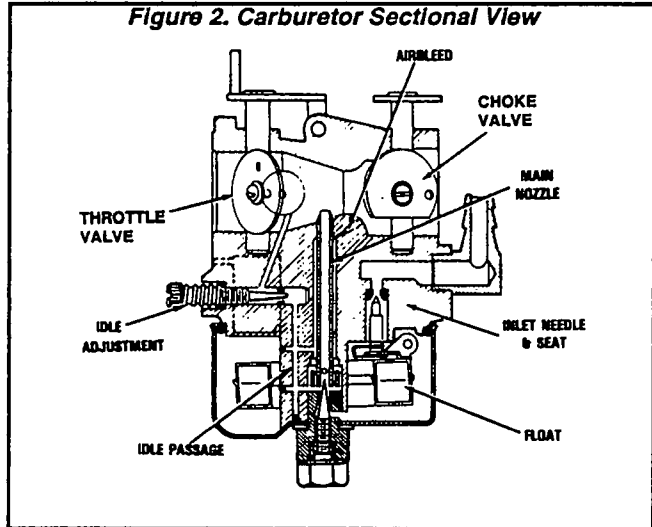

#### CHOKE POSITION:

The choke valve is closed to restrict the flow of air into the engine. As the engine cranks, air pressure in the cylinder is reduced. Since the air intake passage is partially blocked by the choke valve, fuel is drawn from the main nozzle and from the idle discharge port. This creates the very rich fuel mixture required for starting a cold engine.

#### IDLE OPERATION:

The throttle valve is nearly closed to shut off the fuel supply from all ports except the primary idle fuel discharge port. Engine suction then draws fuel only from that port.

#### HIGH SPEED OPERATION:

The throttle valve is wide open. This allows a large volume of air to pass through the carburetor at a high velocity. The high velocity air flow past the carburetor venturi results in a drop in air pressure at the venturi throat. This reduced air pressure draws fuel through the main nozzle that opens into the venturi which then mixes with the air in the air passage.

### Carburetor Disassembly

See Figure 3, next page. The carburetor can be disassembled as follows:

1. Remove the BOWL NUT (Item 3) and the FIBER WASHER (Item 4). Then, remove the FLOAT BOWL (Item 5).
2. Remove the FLOAT PIN (Item 6). Then, remove the FLOAT (Item 7) and the INLET VALVE (Item 8).

## Section 3.4- CARBURETOR

### Carburetor Disassembly (Continued)

3. Remove the IDLE MIXTURE SCREW (Item 22) with SPRING (Item 21).
4. Remove the IDLE SPEED SCREW (Item 20) with SPRING (Item 19).
5. Rotate the THROTTLE VALVE (Item 10) to its closed position and remove the SCREW (Item 9). Remove the THROTTLE VALVE.
6. Remove the THROTTLE SHAFT (Item 14), along with the THROTTLE SHAFT SPRING (Item 13) and the THROTTLE SHAFT SEAL (Item 12).
7. Remove the CHOKE VALVE SPRING RETAINER (Item 18). Remove the CHOKE VALVE (Item 17). Remove the CHOKE SHAFT (Item 15) and the SHAFT SEAL (Item 16).

### Cleaning and Inspection

1. Separate all non-metallic parts.
2. Clean metallic parts in a solvent or a commercial cleaner. Soak the parts no longer than about 30 minutes.
3. Inspect throttle lever and plate. Replace if worn or damaged.
4. Inspect the Idle mixture screw. Check the point as well as its seating surface for damage. Replace the screw, if damaged.
5. The float bowl must be free of dirt and corrosion. Use a new float bowl gasket when assembling the bowl.
6. Check the float for damage. Replace, if damaged. The float setting is fixed and non-adjustable.
7. The carburetor body contains a main jet tube that is pressed in to a fixed depth. Do NOT attempt to remove this tube. Tube movement will adversely affect carburetor metering characteristics.
8. After soaking in solvent, blow out all passages with compressed air.

### Adjustment

The carburetor is equipped only with an idle jet adjustment. This jet controls the fuel-air mixture from light to no-load conditions. The carburetor's high speed jet is FIXED and NON-ADJUSTABLE.

If the engine is operated at a significantly different altitude than the factory (900 feet above sea level), it may become necessary to readjust the idle jet. The fuel-air mixture must be set LEANER for high altitudes. If the unit is moved back to a lower altitude, return the jet to a richer setting.

#### CAUTION!

Do NOT adjust the fuel-air mixture excessively lean. An excessively lean mixture can result in engine damage.

See Figure 4, next page. Turn the IDLE JET inward (clockwise) until it just contacts its seat. DO NOT FORCE. Then, turn the IDLE JET outward (counterclockwise) 1-1/8 turns. This initial adjustment should allow the engine to be started and warmed up.

Figure 3. Carburetor Exploded View

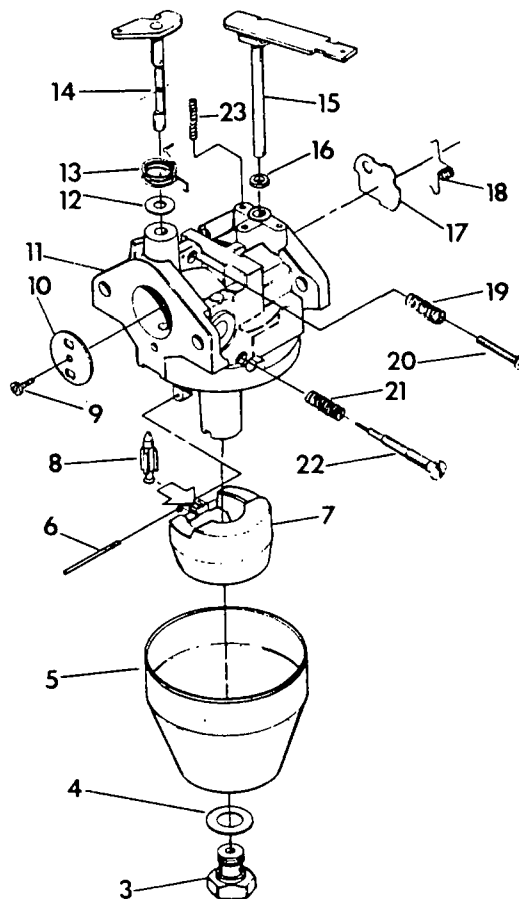

3. Bowl Nut
4. Fiber Washer
5. Float Bowl
6. Float Pin
7. Float
8. Inlet Valve
9. Screw
10. Throttle Valve
11. Body
12. Throttle Shaft Seal
13. Throttle Shaft Spring
14. Throttle Shaft
15. Choke Shaft
16. Choke Shaft Seal
17. Choke Valve
18. Choke Valve Spring Retainer
19. Idle Speed Screw Spring
20. Idle Speed Screw
21. Idle Mixture Screw Spring
22. Idle Mixture Screw.

NOTE: Item 20 used only on Serial No.'s 1354194-1354198 and 1361541-1361600. On other units, Idle Speed Screw has been removed.

After the initial adjustment, start the engine and let it warm up for about five (5) minutes. If the engine runs rough or if exhaust smoke is black, proceed as follows:

## Section 3.4- CARBURETOR

1. With engine running at no-load, turn the IDLE JET clockwise (leaner) until engine speed starts to decrease or fluctuate.
2. Turn the IDLE JET counterclockwise (richer) until engine speed starts to decrease or fluctuate or until black smoke comes from exhaust.
3. Very SLOWLY turn the IDLE JET clockwise (leaner) until engine speed just stabilizes or until black smoke just stops coming from exhaust. DO NOT turn the JET excessively lean.

Figure 4. Carburetor Idle Jet

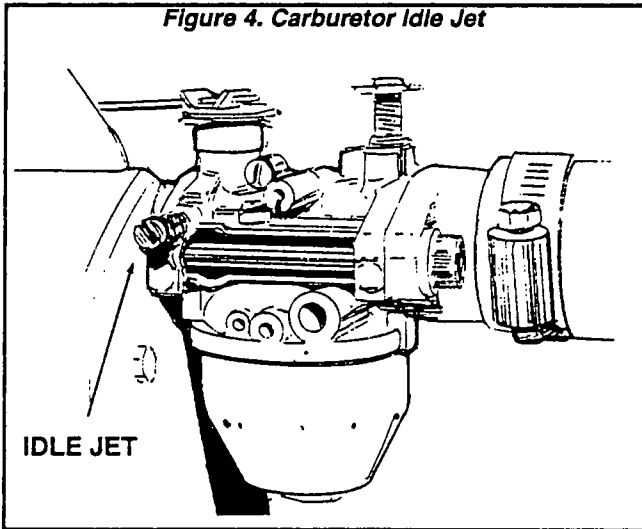

### Engine Speed

Engine speed is controlled by the CCG circuit board. That circuit board signals a stepper motor which moves the throttle linkage. Engine speed will vary in response to changes in generator AC output voltage.

The circuit board monitors the demand for power and adjusts the engine speed accordingly. This permits the engine to deliver only the power needed.

**NOTE:** Do NOT attempt to accelerate the engine manually by grasping the throttle or throttle linkage. This will cause the system to enter a fault condition and terminate generator AC output.

### Throttle Linkage Adjustment

If necessary, the length of the linkage between the stepper motor and the carburetor throttle lever arm can be adjusted. This adjustment helps to establish the proper travel relationship of the linkage. If the adjustment is not correct, the CCG board will not be able to control the full range of engine speed. The following conditions might occur:

- If the throttle linkage is set too short, the system will not be able to provide wide open throttle or full power conditions.
- If the linkage is set too long, the system will not be able to provide closed throttle or no power conditions.

Use the following procedure to ensure the linkage rod is properly adjusted:

1. Start the engine and immediately shut it down. As the engine coasts to a stop, observe from above the engine as the carburetor throttle lever rotates counterclockwise.
2. There should be a gap of about 0.003 inch (0.08-0.5mm) between the stop tab on the throttle lever arm and the stop block on the carburetor casting. See Figure 5.

### CAUTION!

The next step involves bending a spring clip. Do NOT overbend the clip or it may lose its clamping force.

3. Use pliers to lightly compress the spring clip on the carburetor lever arm (Figure 6). This permits the linkage rod to slide freely through the clip. With the clip compressed, rotate the throttle lever in the appropriate direction until there is a 0.003 inch (0.08-0.5mm) gap.
4. Release the spring clip to lock in the adjustment.

Figure 5. Set Gap Between Stop Tab and Stop Block

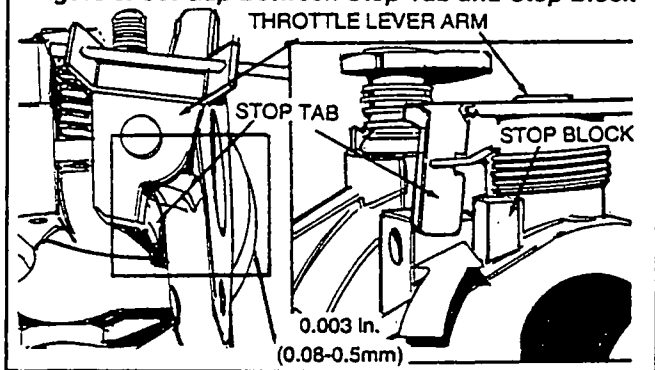
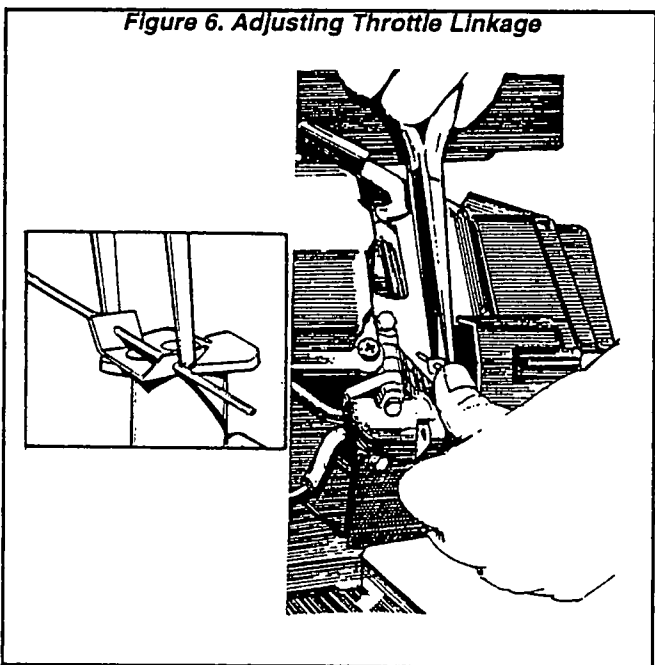

Figure 6. Adjusting Throttle Linkage



## Section 3.4- CARBURETOR

### *Carburetor Removal*

To remove the carburetor from the engine, proceed as follows:

1. Disconnect the carburetor fuel inlet line.
2. Loosen the clamp and disconnect the carburetor air inlet hose.
3. Remove the two M6-1.00 x 90mm screws that retain the carburetor.
4. Remove the carburetor air inlet adapter, the air inlet adapter gasket, carburetor and carburetor to skirt gasket.
5. Remove the sheet metal carburetor skirt.
6. Remove two gaskets and the carburetor spacer.

Figure 7. Carburetor Removal

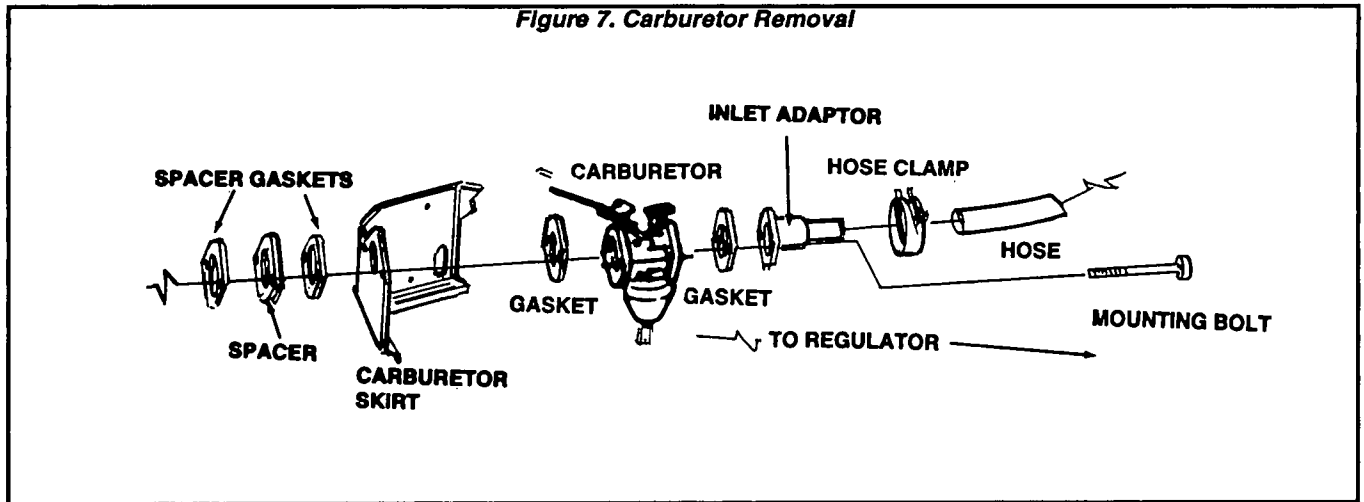

## Section 3.5- AUTOMATIC CHOKE

### General

The GN-190 and GN-220 vertical shaft engines are equipped with an automatic choke. A choke solenoid is attached to the carburetor choke shaft by means of a choke control link. Solenoid operation is controlled by an engine controller circuit board. The circuit board energizes and de-energizes the solenoid cyclically at a rate dependent on ambient temperature during engine cranking only.

### Description

See Figure 1. The CHOKE SOLENOID is retained to a CHOKE COVER by two No. 4-40 SCREWS, LOCKWASHERS and FLATWASHERS. The two screw holes in the COVER are slotted to provide for axial adjustment of the CHOKE SOLENOID. A COTTER PIN retains a CHOKE LINK to the SOLENOID. A CHOKE BI-METAL & HEATER is retained to the SOLENOID by two No. 4-40 SCREWS, LOCKWASHERS and FLATWASHERS.

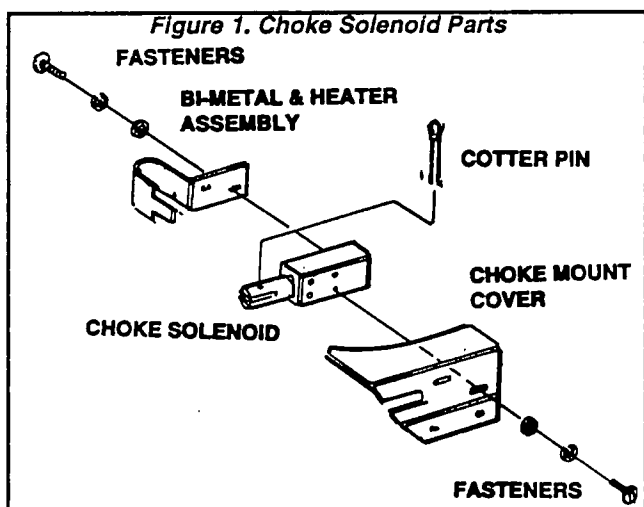

### Operation

**NOTE:** Also see Part 6, "ENGINE ELECTRICAL SYSTEM". The section on DC control system includes additional information on choke operation and the engine controller circuit board.

When the engine is being cranked, engine controller circuit board action energizes the choke solenoid in regular timed cycles. Each time the choke solenoid is energized, it closes the carburetor choke valve. The circuit board's choke timer circuit provides energizes the choke solenoid (pulls it in) about every 2 to 5 seconds'

When the engine starts, cranking is terminated. The choke action is then terminated and the choke setting is determined by a choke heater (CH).

### Operational Check and Adjustment

#### OPERATIONAL CHECK:

Crank the engine. During cranking, the choke solenoid should pull in about every 2 to 5 seconds. If it does NOT pull in, try adjusting the choke.

#### PRE-CHOKE ADJUSTMENT:

With the solenoid NOT pulled in, the carburetor choke valve (choke plate) should be about 1/8 inch from its full open position. If necessary, use needle nose pliers to bend the tip of the BI-METAL until a 1/8 inch setting is obtained.

#### CHOKE SOLENOID ADJUSTMENT:

Loosen the two screws that retain the choke solenoid to its cover. Adjust axial movement of the solenoid plunger by sliding the solenoid in the slotted screw holes of the cover.

Adjust plunger axial movement until (with the carburetor choke valve closed) the plunger is bottomed in the solenoid coil. That is, until the plunger is at its full actuated position.

With the choke valve (choke plate) closed and the plunger bottomed in its coil, tighten the two screws.

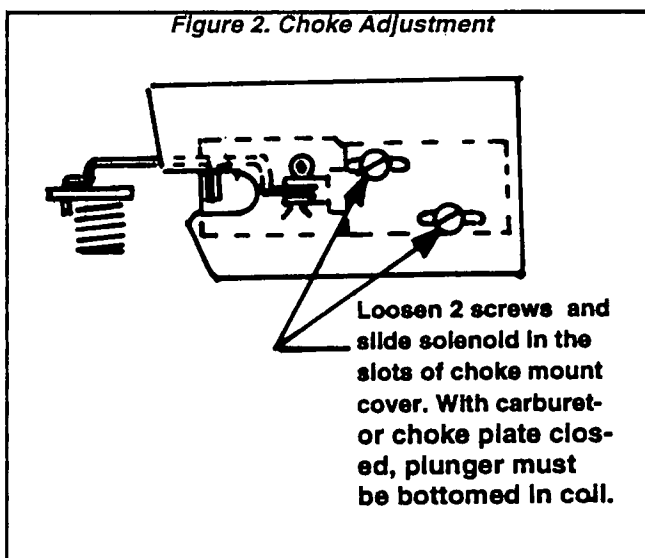

## **Section 3.5- AUTOMATIC CHOKE**

---



## Section 3.6- SPEED CONTROL SYSTEM

### General

The AC generator's output voltage is controlled by a "computerized" speed control system. This system changes engine speed in response to changes in the AC output voltage at varying engine loads. The speed control system consists of (a) the CCG circuit board and (b) a stepper motor.

### CCG Circuit Board

This circuit board utilizes a closed-loop, proportional-derivative controller circuit which regulates the generator's RMS voltage by changing engine speed. The system attempts to maintain an output voltage of about 115 volts at the lowest rpm and 120 volts up to the maximum rpm.

The system also includes a controller which will hold the engine at maximum speed. In this mode, the system will attempt to maintain an output voltage of 105-115 volts.

The CCG circuit board controls a stepper motor by calculating the number of steps the motor needs to take and then supplying the necessary signals to the motor to take those steps.

**NOTE:** Also see "CCG Circuit Board" on Pages 1.2-4 through 1.2-6.

### Stepper Motor

See "Stepper Motor" on Page 1.1-2.

### Testing the CCG Circuit Board

See "Testing the CCG Circuit Board" on Page 1.5-4 and 1.5-5.

### Stepper Motor Problems

#### INTRODUCTION:

Some stepper motor problems that might occur include the following:

- Throttle linkage or carburetor throttle shaft sticking, or linkage disconnected.
- Stepper motor failed or seized.
- Electrical connections to stepper motor broken or disconnected.
- Electrical leads to stepper motor are connected wrong.

#### THROTTLE LINKAGE:

Check throttle linkage and carburetor throttle shaft for binding, disconnected linkage. This type of problem will usually result in the carburetor throttle lever not moving. If the throttle lever does not move, the throttle may be stuck at a permanently open throttle or a permanently closed throttle as follows:

1. If the throttle is open, engine will start but will accelerate quickly and uncontrollably. It will shut down when speed exceeds about 4500 rpm.
2. If the throttle is closed, engine will not accelerate under load. After about 10 seconds, generator AC output will terminate.

#### STEPPER MOTOR FAILED OR SEIZED:

The engine will start but stepper motor will not turn. If an open throttle condition exists, either of the following might occur:

1. Engine may accelerate and shut down at 4500 rpm.
2. Engine may shut down after 15 seconds due to an overvoltage condition.

If throttle is closed, engine will be unable to accelerate under load and AC output will be lost after 10 seconds.

A failed stepper motor may also turn erratically. If this is the case, engine speed and AC output voltage will be erratic under constant load.

#### ELECTRICAL CONNECTIONS BROKEN:

If one or more of the electrical connections to the stepper motor are broken or disconnected, either of the following might occur:

1. The stepper motor may not turn at all.
2. The stepper motor may turn erratically.

If the stepper motor does not turn, symptoms will be the same as for a failed or seized stepper motor.

#### LEADS CONNECTED WRONG:

Incorrectly connected electrical leads to the stepper motor can result in any one of the following:

1. Stepper motor may not turn at all.
2. Stepper motor may turn erratically.
3. Stepper motor may turn backwards.

If the stepper motor does not turn, engine will start and the following may occur:

1. If throttle is open, engine will accelerate and shut down when speed reaches 4500 rpm or after 15 seconds due to overvoltage condition.
2. If throttle is closed, generator AC output will terminate.

If the stepper motor turns erratically, engine speed and AC output voltage will be erratic under a constant load. The AC output will not terminate.

If the stepper motor is turning backwards, engine will accelerate and shut down at 4500 rpm.

## Section 3.6- SPEED CONTROL SYSTEM

Figure 1. Speed Control System

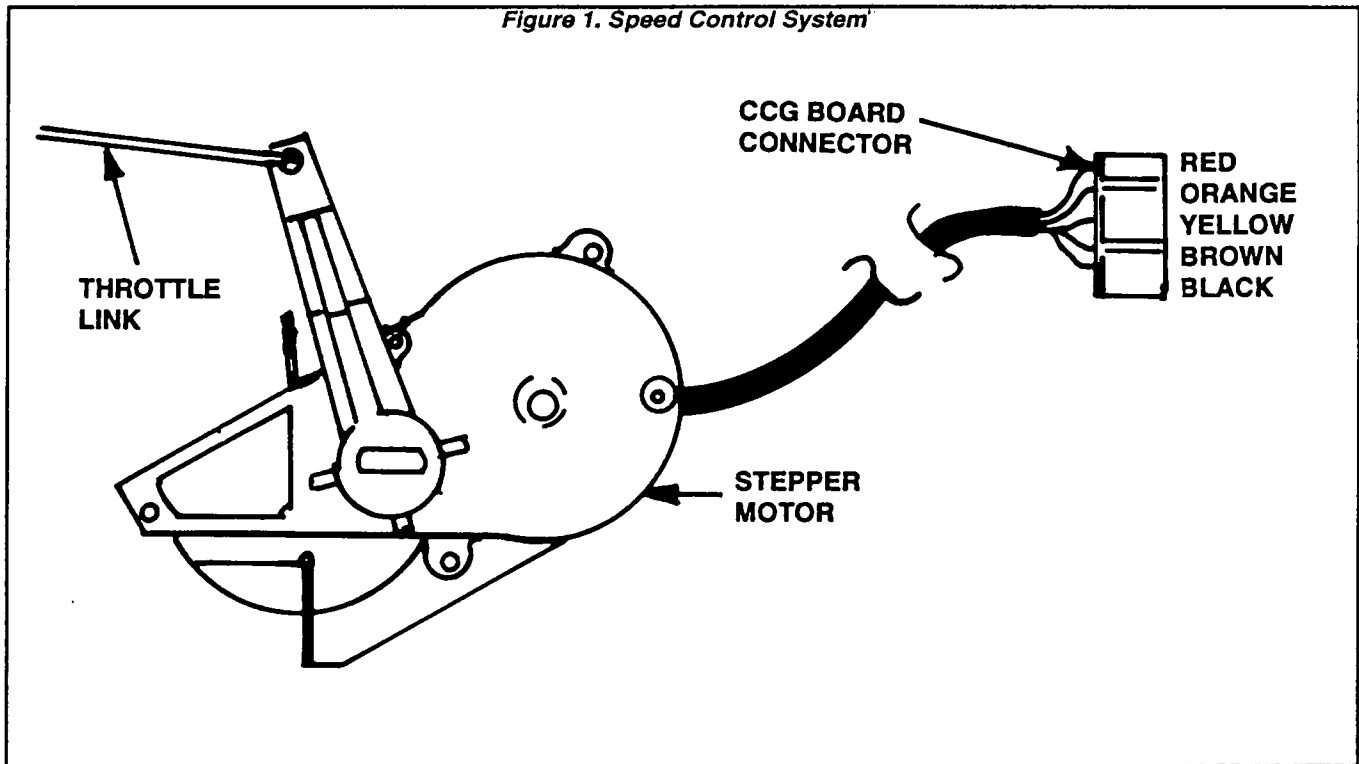

### Testing the Stepper Motor

#### GENERAL:

The Stepper Motor consists of an electric motor plus a small gearbox. It is shown pictorially and schematically in Figure 3. The four (4) motor windings can be tested for (a) continuity and (b) shorts to the case.

It is difficult to perform an operational test of the motor since the amount of motor arm movement is so small.

#### TESTING FOR OPEN CONDITION:

To test the motor windings for an open circuit condition, proceed as follows:

1. Unplug the Stepper Motor connector from its receptacle on the CCG circuit board.
2. Set a volt-ohm-millammeter (VOM) to its "Rx1" scale and zero the meter.
3. Connect one VOM test probe to the connector pin to which the RED wire attaches. This is the +DC side of all windings. Then, connect the other VOM test probe as follows:
  - a. To the ORANGE wire connector pin. Approximately 19-21 ohms should be indicated.
  - b. To the YELLOW wire connector pin. About 19-21 ohms should be read.
  - c. To the BROWN wire pin for a reading of 19-21 ohms.
  - d. To the BLACK wire connector pin for a reading of about 19-21 ohms.

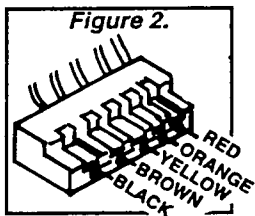

#### TESTING FOR SHORTED CONDITION:

1. Set the VOM to its "Rx10,000" or "Rx1K" scale and zero the meter.
2. Connect one VOM test probe to the RED wire connector pin, the other test probe to the Stepper Motor case. The meter should read "Infinity". Any reading other than "infinity" indicates a shorted winding.

Replace the Stepper Motor if it fails any part of the test.

Figure 3. The Stepper Motor

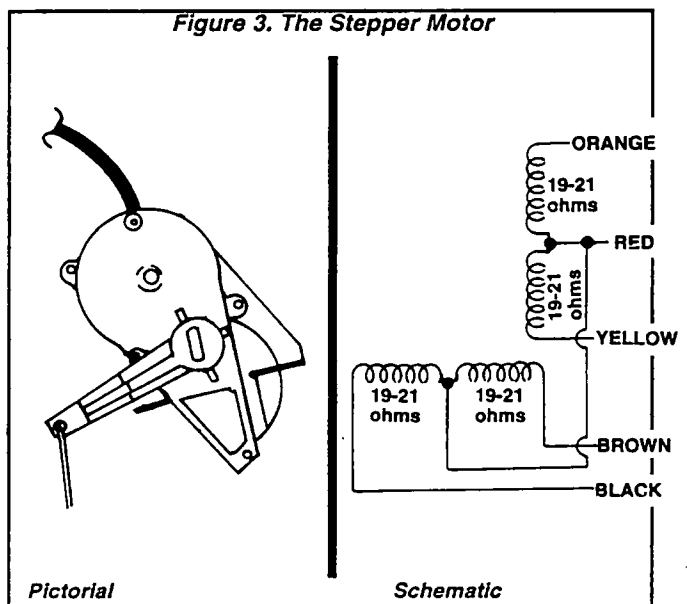

# Part 4 GASEOUS FUEL SYSTEM

## COMPUTER CONTROLLED VARIABLE SPEED RV GENERATORS

Series NP-30G and NP-40G

SECTION	TITLE
4.1	INTRODUCTION TO FUEL SYSTEM
4.2	SHUTOFF VALVE & REGULATOR
4.3	CARBURETOR

NOTE: Information on the following is the same as for the "GASOLINE FUEL SYSTEM" (Part 3):

Air Cleaner & Air Intake (Section 3.2)  
Speed Control System (Section 3.6)

## Section 4.1- INTRODUCTION TO FUEL SYSTEM

### General Information

Some RV generator models are equipped with fuel systems that utilize LP gas as a fuel. The initials "LP" stand for "liquefied petroleum". This gas is highly volatile and can be dangerous if handled or stored carelessly.

All applicable laws, codes and regulations pertaining to the storage and handling of LP gas must be complied with. The installation of such fuel systems must also be in compliance with such laws, codes and regulations. Service technicians who work on these systems must do nothing that might cause the system to be in non-compliance with regulations.

Regulations established by the Recreational Vehicle Industry Association (RVIA) must be followed in the installation, use and servicing of such systems.

#### DANGER!

LP GAS IS HIGHLY EXPLOSIVE. THE GAS IS HEAVIER THAN AIR AND TENDS TO SETTLE IN LOW AREAS. EVEN THE LIGHTEST SPARK CAN IGNITE THE GAS AND CAUSE AN EXPLOSION. ONLY COMPETENT, QUALIFIED GAS SERVICE TECHNICIANS SHOULD BE ALLOWED TO INSTALL, TEST, ADJUST OR SERVICE THE GASEOUS FUEL SYSTEM. INSTALLATION OF A GASEOUS FUEL SYSTEM MUST BE IN STRICT COMPLIANCE WITH APPLICABLE CODES. FOLLOWING INSTALLATION NOTHING MUST BE DONE THAT MIGHT RENDER THE SYSTEM IN NON-COMPLIANCE WITH SUCH CODES.

#### DANGER!

USE ONLY APPROVED COMPONENTS IN THE GASEOUS FUEL SYSTEM. IMPROPER INSTALLATION OR USE OF UNAUTHORIZED COMPONENTS CAN RESULT IN FIRE OR AN EXPLOSION. USE APPROVED METHODS TO TEST THE SYSTEM FOR LEAKS. NO LEAKAGE IS PERMITTED. DO NOT PERMIT FUEL VAPORS TO ENTER THE VEHICLE INTERIOR.

### Advantages of Gaseous Fuels

The use of gaseous fuels may result in a slight power loss, as compared to gasoline. However, that disadvantage is usually compensated for by the many advantages of gaseous fuels. Some of these advantages are:

- A low residue content results in minimum carbon formation in the engine.
- Reduced sludge buildup in the engine oil.
- Reduced burning of valves as compared to gasoline.

- No wash-down of engine cylinder walls during cranking and startup.
- Excellent anti-knock qualities.
- A nearly homogeneous mixture in the engine cylinders.
- Fuel can be stored for long periods without breakdown.

### Fuel System Components

When the generator set is shipped from the factory, the following fuel system components are included with the unit:

1. A Fuel Lockoff Solenoid
2. The LP Gas Regulator
3. The carburetor.
4. Interconnecting lines and fittings.

Components that must be added by the generator installer include the following:

1. A VAPOR WITHDRAWAL type fuel tank.
2. A PRIMARY REGULATOR that will deliver a fuel pressure to the Fuel Lockoff Solenoid of about 11 psi.
3. Interconnecting lines and fittings.

### Vapor Withdrawal

LP gas is stored in pressure tanks as a liquid. Gaseous fuel system components installed on the generator are designed for "vapor withdrawal" type systems. Such systems use the gas vapors that form above the liquid fuel in the tank. Do not attempt to use any "liquid withdrawal" type tank with the RV generator.

*NOTE: "Liquid withdrawal" type systems use the liquid fuel from the tank. The liquid fuel must be vaporized before it reaches the carburetor. Fuel vaporization is usually accomplished by porting the liquid fuel through some kind of heating device.*

### Important Considerations

When servicing the gaseous fuel system the following rules apply:

- All lines, fittings, hoses and clamps must be free of leaks. Apply pipe sealant to threads when assembling threaded connectors to reduce the possibility of leakage.
- Following any service, the system must be tested for leaks using APPROVED test methods.
- Optimum gas pressure at the inlet to the fuel lockoff solenoid and secondary regulator is 11 inches of water column. Do NOT exceed 14 inches water column.

## Section 4.1- INTRODUCTION TO FUEL SYSTEM

### Important Considerations (Continued)

**NOTE:** A PRIMARY REGULATOR, between the tank and the fuel lockoff solenoid, is required to ensure that correct gas pressure is delivered to the lockoff solenoid.

- The generator installer's connection point is at the fuel lockoff solenoid which has a 3/4 inch (female) connection.
- A length of flexible hose is required between the fuel lockoff solenoid and rigid fuel piping, to allow for vibration and/or shifting of the unit. This line must be at least six (6) inches longer than necessary.

### Fuel Supply Lines

When servicing or repairing the gaseous fuel system, the following rules apply to gaseous fuel supply lines:

- The LP gas lines must be accessible but must also be protected against possible damage.
- Do NOT connect electrical wiring to any gaseous fuel line. Do NOT route electrical wiring alongside the gaseous fuel lines.
- Route the gaseous fuel lines AWAY from hot engine exhaust mufflers and piping.

- Gas lines should be retained with metal clamps that do not have any sharp edges.
- Gaseous fuel lines and primary regulators must be properly sized to deliver adequate fuel flow to the generator engine. The generator requires at least 67 cubic feet of gas per hour for its operation.

**NOTE:** An existing primary regulator may be used to deliver gas to the fuel lockoff solenoid provided it has sufficient flow capacity for the generator and other gas appliances in the circuit. If the existing primary regulator does not have a sufficient capacity (a) replace it with one that has adequate flow capacity, or (b) install a separate primary regulator having at least a 67 cubic feet per hour capacity.

### Excess Flow Valve

Rules established by the National Fire Protection Association (NFPA) and the Recreation Vehicle Industry Association (RVIA) require that the LP gas tank be equipped with an excess flow valve. This valve and the gaseous fuel lines must be carefully sized so the excess flow valve will close in the event of line breakage.

Shutoff valves on the fuel supply tank and elsewhere in the system must be fully open when operating the generator. The excess flow valve will function properly only if all valves are fully open and fuel lines are properly sized.

Figure 1. A Typical LP Gas Fuel System

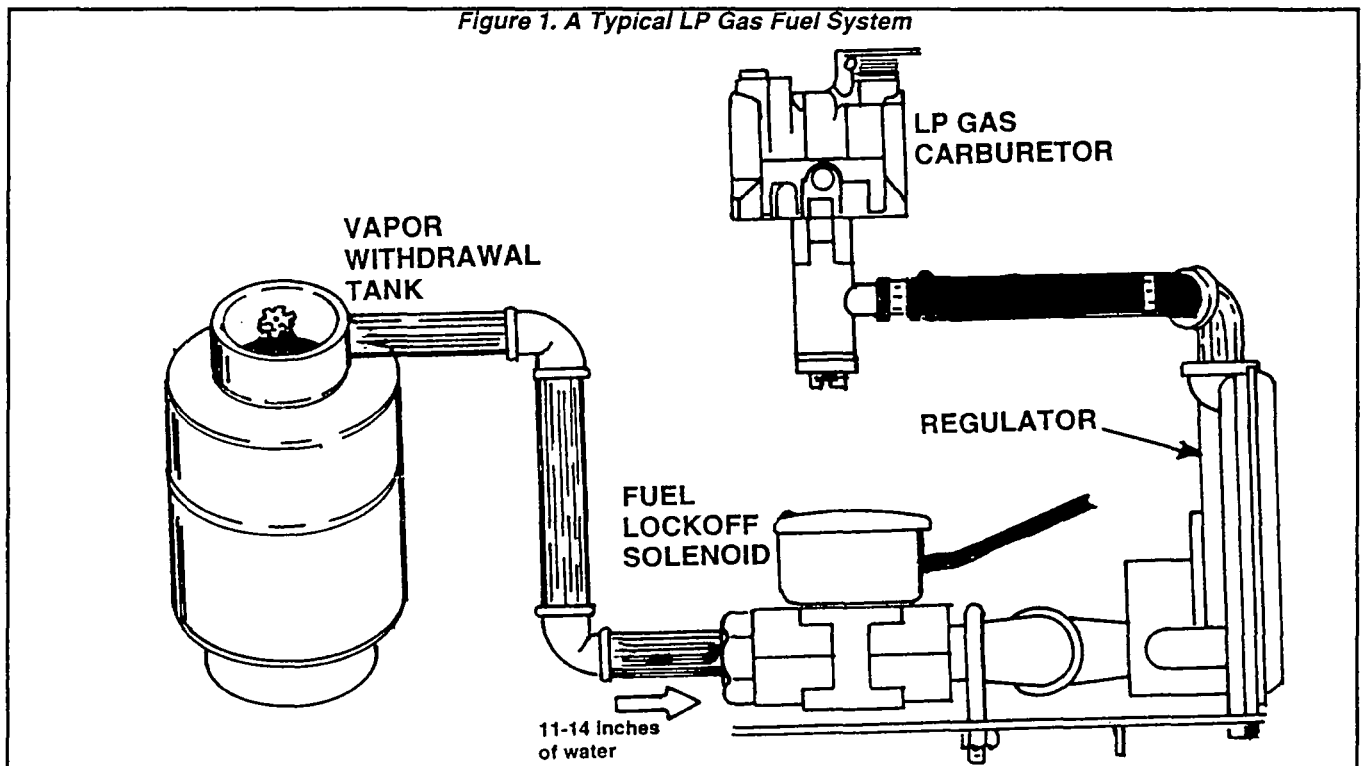

## Section 4.1- INTRODUCTION TO FUEL SYSTEM

### *Gaseous Carburetion*

Gas at positive pressure is delivered from the fuel lockoff solenoid to the inlet of the regulator (about 11-14 inches of water).

As the engine piston moves downward on its intake stroke, air is drawn into the area above the piston through the carburetor venturi. A negative pressure is created at the venturi which is proportional to the amount of air that is flowing.

The negative pressure at the carburetor venturi acts on the regulator diaphragm to pull the diaphragm toward the source of low pressure. A lever, attached to the diaphragm, opens a metering valve which allows gas to enter and flow through the carburetor.

The greater the air flow through the carburetor venturi, the lower the pressure at the venturi throat. The lower the pressure at the venturi throat, the greater the movement of the diaphragm and the more the metering valve opens.

Figure 2. Gas Carburetion Diagram

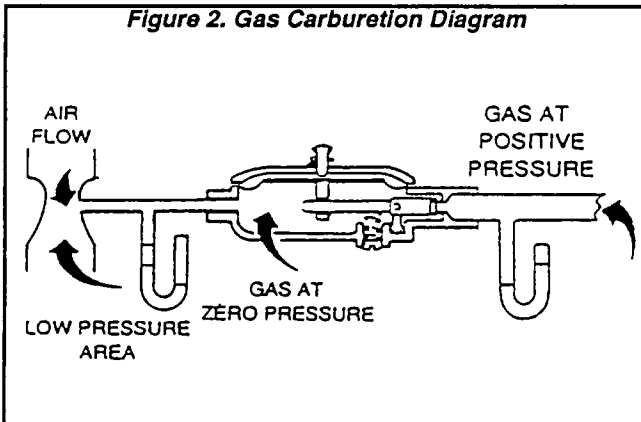

The following requirements of the secondary regulator must be emphasized:

- It must be sensitive to pressure changes in the carburetor venturi throughout the entire operating range.
- It must positively stop the flow of gas when the engine is not running.
- The slightest air flow through the carburetor venturi must move the regulator valve off its seat and permit gas flow.

### *Leakage Testing*

Whenever any lines, fittings or other components of the fuel system have been removed and replaced, the system should be carefully checked for leaks before it is placed into service.

To check for leakage, start the engine and let it run. Then use a soap and water solution or an approved commercial leak detector solution to determine if any leakage exists. No leakage is permitted.

#### **DANGER!**

**DO NOT USE FLAME TO CHECK FOR LEAKAGE. GASEOUS FUEL LINES BETWEEN THE TANK AND SECONDARY REGULATOR ARE UNDER A POSITIVE PRESSURE (ABOUT 11 INCHES OF WATER COLUMN). HOWEVER, GAS PRESSURE AT THE OUTLET SIDE OF THE SECONDARY REGULATOR IS A NEGATIVE PRESSURE (ABOUT 1 INCH WATER COLUMN). THIS NEGATIVE PRESSURE CAN DRAW FLAME INSIDE A LINE OR FITTING AND CAUSE AN EXPLOSION.**

#### **IMPORTANT!**

**APPLY PIPE SEALANT TO THREADS OF ALL FITTINGS TO REDUCE THE POSSIBILITY OF LEAKAGE.**

## **Section 4.1- INTRODUCTION TO FUEL SYSTEM**

# Section 4.2- SHUTOFF VALVE & REGULATOR

## General

See Figure 1. The fuel shutoff valve (lockoff solenoid) and the secondary regulator are retained to a flat mounting bracket which, in turn, mounts to the generator base cover. The fuel lockoff solenoid is retained to the mounting bracket by means of a u-bolt. The secondary regulator is retained to the mounting bracket with two 1/4"-20 x 3/4" long capscrews.

## Parts List for Figure 1

ITEM	QTY	DESCRIPTION
1	1	LP Gas Regulator
2	1	Fuel Lockoff Solenoid
3	1	U-Bolt- 1.25" wide (5/16"-18)
4	2	3/4" NPT Street Elbow
5	1	3/4" NPT Close Nipple
6	1	3/8" NPT Street Elbow
7	1	1/2" x 3/8" NPT Fitting
8	1	Hose Clamp
9	1	1/2" ID Hose (11.5" long)
10	2	1/4"-20 x 3/4" Capscrew
11	2	1/4" Lockwasher
12	2	5/16" Lockwasher
13	2	5/16"-18 Hex Nut
14	1	Regulator Mounting Bracket
15	1	Sleeving (9" long)

Figure 1. Shutoff Valve & Regulator

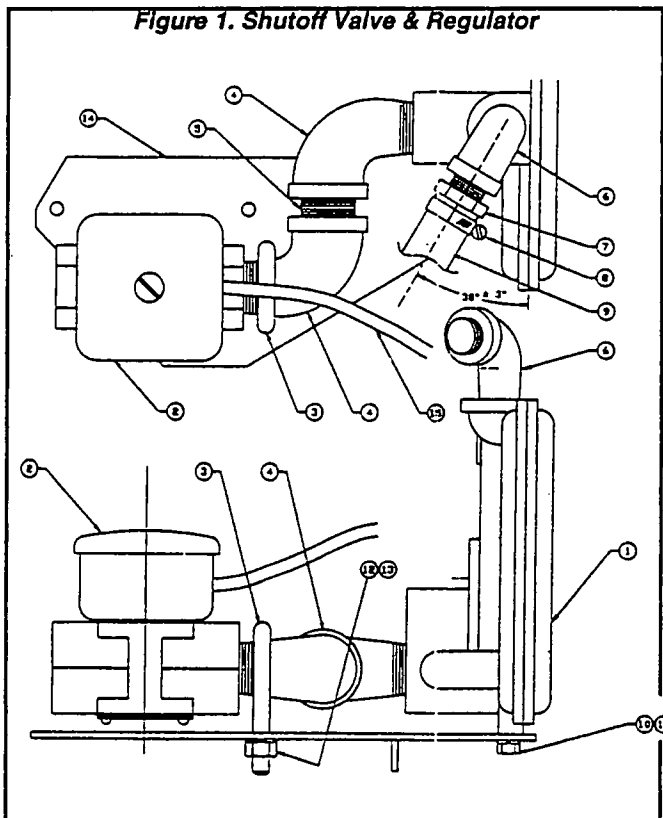

## Adjustments

There are no adjustments on the fuel lockoff solenoid or the secondary regulator. This system is NOT equipped with a load block.

## The LP Gas Regulator

The secondary regulator is a GARRETSON® Model KN. It is designed for simplicity and simple operation. The regulator is suitable for use with low pressure vaporized gaseous fuels where dependable starting is a requirement. Recommended inlet pressure to the regulator is 11 inches water column.

The regulator comes with a 3/4 inch NPT fuel inlet and a 3/8 inch NPT fuel outlet.

The LOCKOFF ADJUSTMENT SCREW shown in Figure 2 has been preset at the factory. No additional adjustment is authorized.

Figure 2. LP Gas Regulator

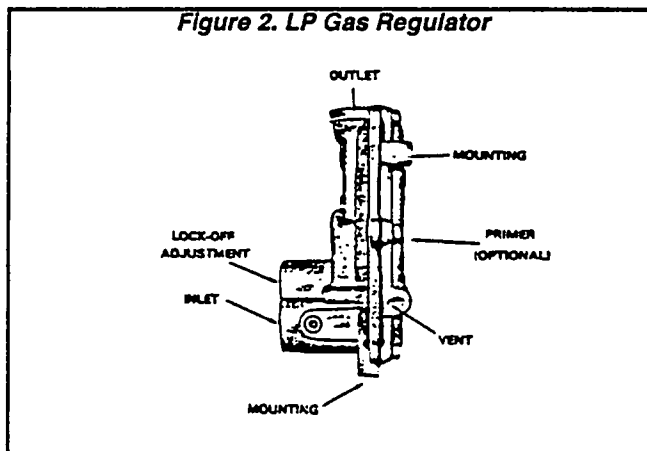

## DANGER!

DO NOT ATTEMPT TO ADJUST THE GAS REGULATOR. REGULATOR ADJUSTMENTS SHOULD BE ATTEMPTED ONLY BY QUALIFIED GAS SERVICE TECHNICIANS WHO HAVE THE KNOWLEDGE AND SPECIALIZED EQUIPMENT FOR SUCH ADJUSTMENTS.

## Testing the Fuel Lockoff Solenoid

### GENERAL:

The fuel lockoff solenoid is energized open by 12 volts DC power from the engine controller circuit board during engine cranking. The solenoid can also be energized open without cranking by actuating the fuel primer switch on the generator panel.

### TEST PROCEDURE:

1. Set a volt-ohm-milliammeter (VOM) to read battery voltage (12 VDC).



## Section 4.2- SHUTOFF VALVE & REGULATOR

### Testing the Fuel Lockoff Solenoid (Continued)

2. Connect the VOM test leads across Wire 14 (Red) at the solenoid and a clean frame ground.
3. Set the fuel primer switch on the generator panel to its ON position.
  - a. The meter should indicate battery voltage.
  - b. The solenoid should energize open.

#### **RESULTS OF TEST:**

1. If battery voltage is indicated but the solenoid does NOT energize, replace the lockoff solenoid.
2. If battery voltage is NOT indicated, a problem exists in the DC control system. See Parts 6, "ENGINE ELECTRICAL SYSTEM".

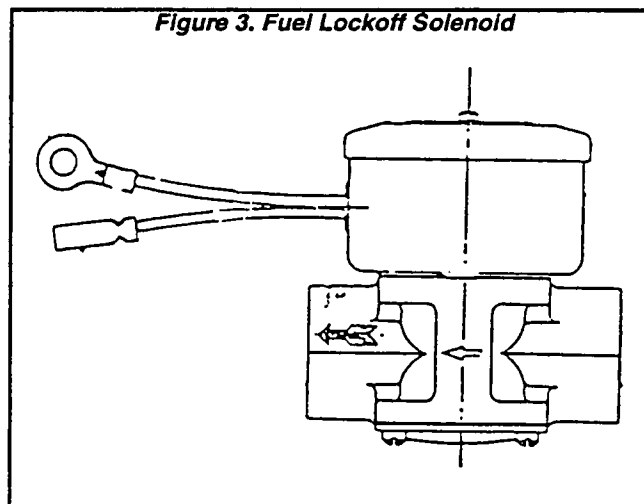

## Section 4.3- CARBURETOR

### ***General***

The carburetor is designed for use with LP gas in its vapor form. The following specifications apply:

Carburetor Inlet Diameter . . . . 1.02 inch (26mm)  
Carburetor Outlet Diameter . . 0.78 inch (20mm)  
Venturi Diameter . . . . . 0.63 inch (16mm)  
Main Jet Diameter  
Number .....370  
Measured Size.....0.145 inch (3.7mm)

### ***Carburetion***

Refer to "Gaseous Carburetion" in Section 4.1 (Page 4.1-3).

### ***Carburetor Adjustment***

The LP gas carburetor used on NP-30 and NP-40 generator sets is equipped with a fixed jet and is non-adjustable.

### ***Carburetor Removal***

Refer to Part 3, Section 3.4, Page 3.4-4 for carburetor removal procedures.

### ***Disassembly and Reassembly***

The carburetor is replaced as an entire assembly. Disassembly and reassembly is not required.

Figure 1. LP Gas Carburetor

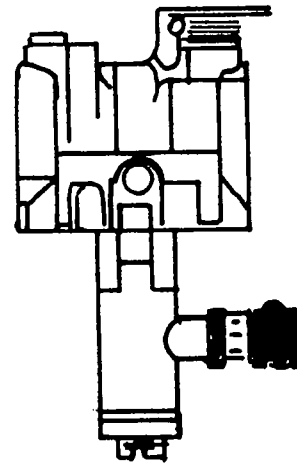

## **Section 4.3- CARBURETOR**

---

**Part 5**  
**ENGINE OIL**  
**& COOLING**  
**SYSTEM**

**COMPUTER**  
**CONTROLLED**  
**VARIABLE**  
**SPEED RV**  
**GENERATORS**  
Series NP-30G and NP-40G

SECTION	TITLE
5.1	ENGINE OIL SYSTEM
5.2	ENGINE COOLING SYSTEM

# Section 5.1- ENGINE OIL SYSTEM

## Introduction to Oil System

The engine oil system serves to (a) reduce friction between parts, (b) cool the engine, and (c) establish a slightly negative pressure in the crankcase to prevent oil leakage. Major components that will be discussed in this section include the following:

- Oil Pickup Screen.
- Oil Pump.
- Crankshaft Oil Seals.
- Pressure Relief Valve.
- Breather Assembly.
- Oil Sump.
- Oil Filter Support Assembly.

## Oil Flow

See Figure 1. The oil pump draws oil from the oil sump through an oil pickup screen and delivers it to the areas requiring lubrication as follows:

1. Through a cored channel in the oil sump to the crankcase journal at one end of the crankshaft.
2. Through the hollow camshaft to the camshaft bearing.
3. Through a cored passage in the crankcase to the crankshaft journal.
4. Through the crankshaft to the crankpin and connecting rod bearing.

Figure 1. Oil System Diagram

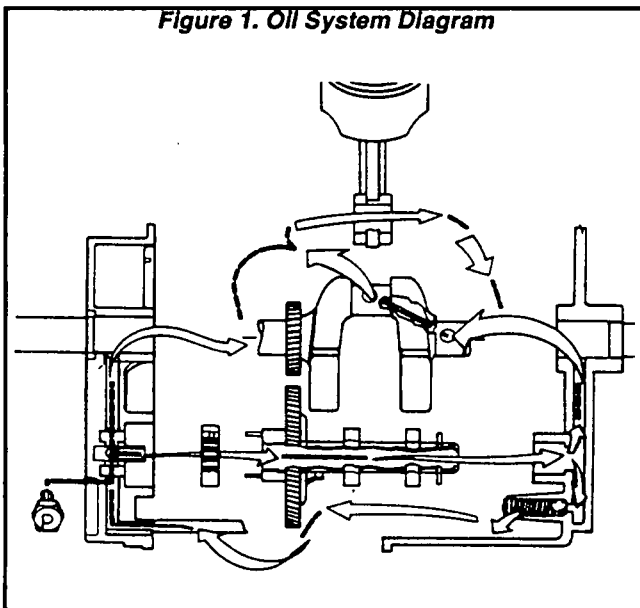

## Oil Pickup Screen

### DESCRIPTION:

The oil pickup screen consists of a cylindrical screen which is open at one end only. The screen's open end fits over a tubular protrusion in the oil sump, just behind the oil filter support. Also see "Oil Filter Support Assembly".

### INSPECTION:

To gain access to the screen, remove the oil filter support and its gasket. Pull the screen off its tubular protrusion. Clean the screen in solvent, then inspect for damage. Replace the screen if necessary.

## Oil Pump

### DESCRIPTION:

The oil pump is of the trochoid type. Its inner rotor rotates on a shaft provided in the camshaft bore of the oil sump. The outer rotor is installed over two drive pins on the end of the camshaft and is driven by camshaft rotation.

Figure 2. Oil Pump

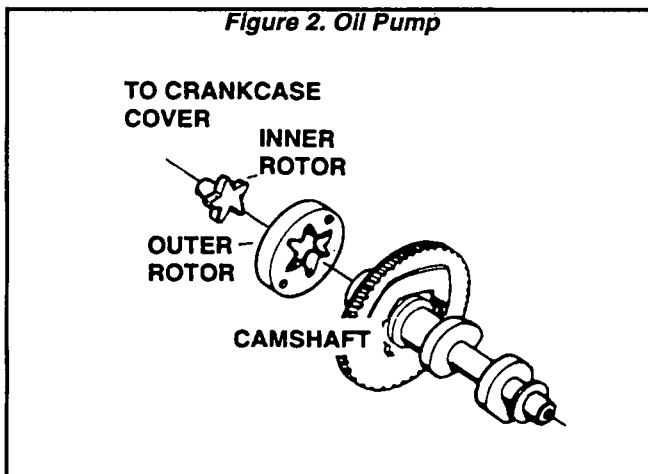

### INSPECTION:

See Figure 3. Inspect the inner and outer rotors of the pump for damage and wear. Use a feeler gauge to check tip clearance of the rotor (measured on the shaft in the oil sump). Check the bore inner diameter and the thickness of the inner rotor. If wear limits are exceeded, replace the appropriate part(s).

**PUMP TIP CLEARANCE**  
(MEASURED ON SHAFT IN OIL SUMP)  
DESIGN CLEARANCE: 0.0000-0.0010 inch  
(0.000-0.025mm)  
WEAR LIMIT: 0.004 inch (0.105mm) Maximum

**INNER PUMP ROTOR BORE**  
DESIGN BORE: 0.354-0.355 inch (9.000-9.019mm)  
WEAR LIMIT: 0.357 inch (9.034mm) Maximum

**INNER ROTOR THICKNESS**  
DESIGN THICKNESS: 0.312-0.315 inch (7.95-8.00mm)  
WEAR LIMIT: 0.311 inch (7.90mm) Minimum

Replace any part that is damaged or worn excessively. The shaft on which the inner rotor rotates is NOT replaceable (oil sump must be replaced).

# Section 5.1- ENGINE OIL SYSTEM

## Oil Pump (Continued)

### INSPECTION (CONT'D):

Inspect the outer drive pins on the camshaft. Look for breakage, bending, other damage. These are roll pins which can be removed and replaced.

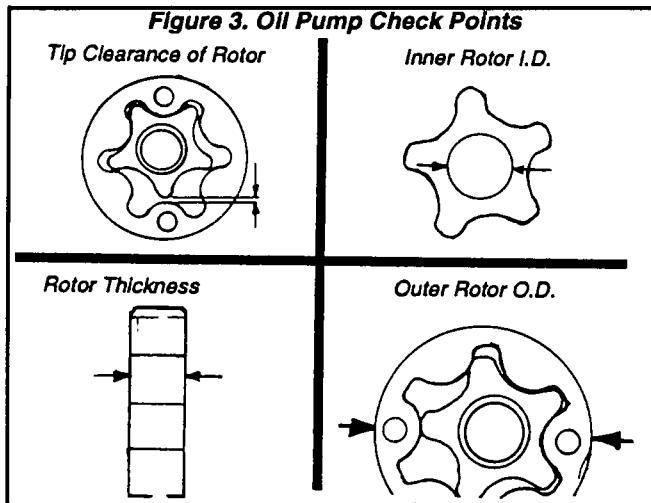

## Crankshaft Oil Seals

An oil seal is provided in the crankcase and in the oil sump, to prevent leakage past the crankshaft journals. See Figure 4.

A defective or leaking seal can be replaced. If the crankshaft has been removed from the engine, old seals can be removed by tapping out with a screwdriver or punching them out from inside. Oil seal pullers are available commercially, for seal removal with the crankshaft installed.

Always use a seal protector when installing the crankshaft into its crankcase bore and when installing the oil sump over the crankshaft.

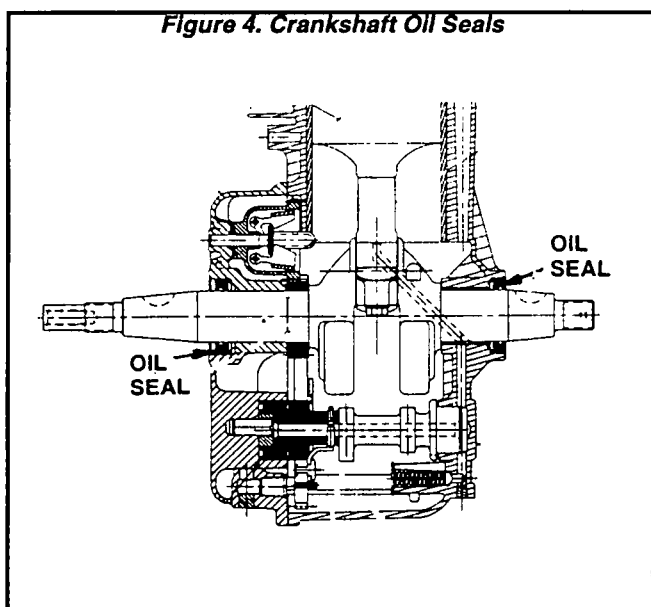

## Pressure Relief Valve

### DESCRIPTION:

A ball type pressure relief valve is located in a bore of the crankcase. The ball and spring are retained in the crankcase bore by a spring retainer.

The Relief Valve serves to limit oil pressure to a maximum value. The ball will remain against its seat as long as oil pressure in the crankcase oil passage is below approximately 30 psi (29 kg/cm<sup>2</sup>). Should oil pressure increase above that value, the ball will be forced off its seat to relieve excess pressure into the crankcase.

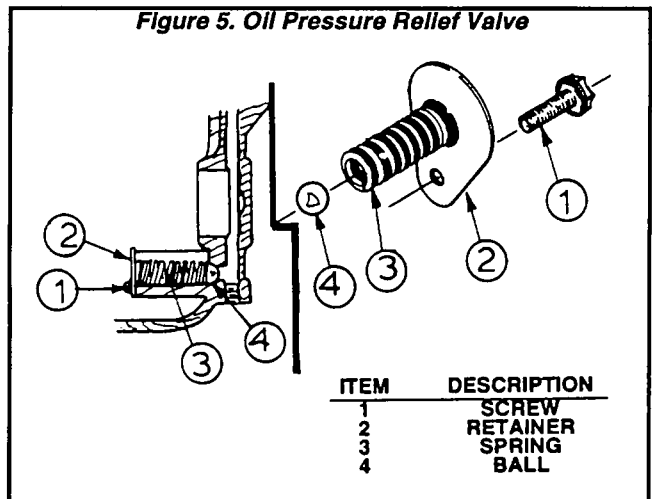

### INSPECTION:

Remove the 8mm screw that retains the spring RETAINER to the crankcase interior. Remove the RETAINER, SPRING and BALL. Clean all parts in solvent.

Inspect the BALL and RETAINER for damage, excessive wear. Replace any damaged or worn components. Inspect the SPRING and replace if damaged or worn.

Apply a known test load to the SPRING, sufficient to compress the spring to a length of 1.03 inch (26.3mm). The amount of the test load at the stated spring length should be as follows:

**FORCE REQUIRED TO COMPRESS  
RELIEF VALVE SPRING TO 1.03 INCH (26.3mm)  
0.86-0.95 pounds (0.43-0.39 kg)**

If the test load at the stated length is not within limits, replace the SPRING.

## Breather Assembly

### DESCRIPTION:

A crankcase breather is located in the crankcase assembly.

## Section 5.1- ENGINE OIL SYSTEM

The breather serves to maintain a partial vacuum in the engine crankcase, to prevent oil from being forced past oil seals, gaskets or rings.

See Figure 6. A reed type breather valve permits excess pressure to be vented out of the crankcase and to atmosphere through a breather tube. A breather retainer limits the movement of the breather valve. Two small oil return holes in the breather cup allow condensed oil vapors to drain back to the crankcase. A "steel wool" type breather separator separates the breather cup from the breather cover and breather tube opening.

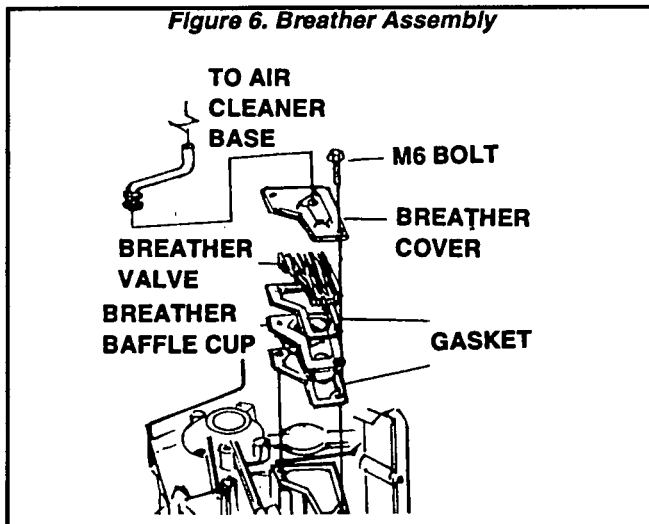

### INSPECTION:

Remove the breather hose. Inspect it for cracks, damage, hardening. Replace, if necessary.

Clean the breather cover and breather cup in commercial solvent. Check that the two small drain holes in the breather cup are open; open with a length of wire, if necessary.

Inspect the rivets that retain the reed type breather valve, make sure they are tight. Also check that the valve seats flat on the breather cup around the entire surface of the valve.

### Oil Sump

#### DESCRIPTION:

The die cast aluminum oil sump is retained to the crankcase with six (6) flanged head bolts. Install a new gasket between the oil sump and crankcase each time the oil sump is removed.

Bores are provided in the oil sump for (a) oil pump rotors and camshaft, (b) crankshaft, (c) governor gear assembly, (d) oil pickup. Cored oil passages are provided from the pickup to the pump and from the pump to the crankshaft bore.

### INSPECTION:

Clean the oil sump and blow dry with compressed air. Use compressed air to blow out all oil passages. Inspect the sump for cracks, damage, etc. Check the following bores in the oil sump for wear:

**CRANKSHAFT BEARING BORE DIAMETER  
GN-190 ENGINE**  
DESIGN DIAMETER: 1.103-1.105 Inch (28.030-28.058mm)  
WEAR LIMIT: 1.106 Inch (28.088mm) Maximum

**CRANKSHAFT BEARING BORE DIAMETER  
GN-220 ENGINE**  
DESIGN DIAMETER: 1.104-1.105 Inch (28.040-28.065mm)  
WEAR LIMIT: 1.106 Inch (28.092mm) Maximum

**CAMSHAFT BEARING BORE DIAMETER  
GN-190 & GN-220 ENGINE**  
DESIGN DIAMETER: 1.299-1.300 Inch (33.00-33.03mm)  
WEAR LIMIT: 1.302 Inch (33.06mm) Maximum

**OIL PUMP INNER ROTOR SHAFT DIAMETER  
GN-190 & GN-220 ENGINE**  
DESIGN DIAMETER: 0.353-0.354 Inch (8.969-8.987mm)  
WEAR LIMIT: 0.352 Inch (8.949mm) Minimum

### Oil Filter Support

An oil filter support and its gasket are retained to the oil sump by four (4) M6-1.00 bolt.

A threaded bore is provided in the support for a low oil pressure switch. This switch will protect the engine against damaging low oil pressure by shutting the engine down automatically if oil pressure should drop below a pre-set low limit.

A high oil temperature switch is retained to the support by two (2) M5 screws and lockwashers. This thermal sensor will protect the engine against damaging high temperature conditions through automatic shutdown.

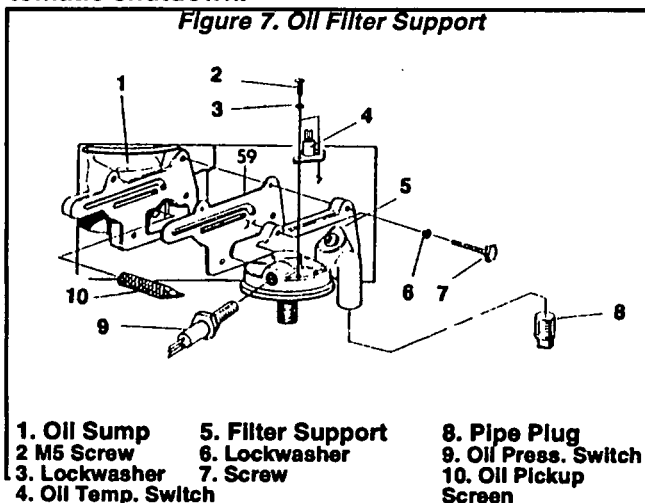

- |                     |                   |                       |
|---------------------|-------------------|-----------------------|
| 1. Oil Sump         | 5. Filter Support | 8. Pipe Plug          |
| 2. M5 Screw         | 6. Lockwasher     | 9. Oil Press. Switch  |
| 3. Lockwasher       | 7. Screw          | 10. Oil Pickup Screen |
| 4. Oil Temp. Switch |                   |                       |

# **Section 5.1- ENGINE OIL SYSTEM**

---



## Section 5.2- ENGINE COOLING SYSTEM

### General

The engine and generator are air-cooled. It is absolutely essential that an adequate flow of air for cooling, ventilation and combustion be supplied to the RV generator. Without sufficient air flow, the engine-generator will quickly overheat. Overheating can result in serious damage to the equipment, as well as fire and possible injury. Air must be drawn into the generator compartment of the recreational vehicle at a sufficiently high rate. The air must then be exhausted from the compartment at a sufficiently high rate.

### Generator Air Flow

A cooling fan is attached to the generator's permanent magnet rotor. This pressure fan draws air into the top of the generator, into the side of the control panel, and across the engine-generator and electronic components.

A suction fan is attached to the engine crankshaft. This fan draws the heated air into a collector pan at the bottom of the engine-generator, where it is directed across the exhaust muffler and then deflected out to ambient air.

Figure 1. Engine-Generator Air Flow

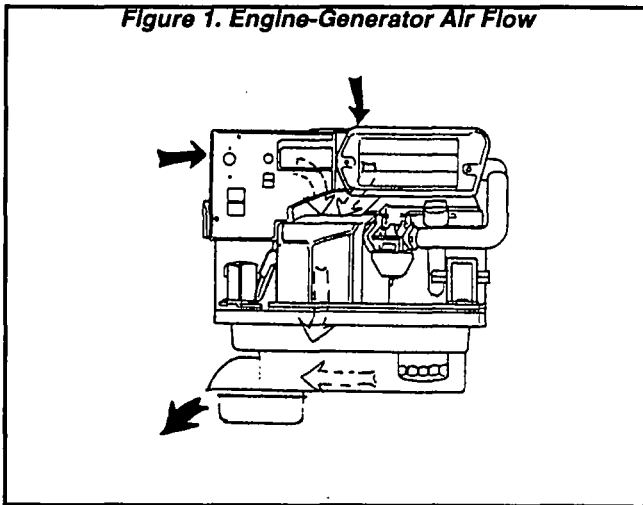

### Air Flow into Generator Compartment

#### GENERAL:

The installer of an RV generator into a vehicle must provide air openings that will supply the needed air for cooling, ventilation and combustion. Technicians who service the engine-generator must not do anything that will restrict this air flow. Any one or a combination of several different methods may be used to deliver the required air flow. The method used by the installer will depend on the method used to mount the generator in the vehicle, as follows:

1. If the generator set is mounted in a compartment above the vehicle frame, air openings can be provided in the compartment door.

a. Ideally, three openings should be provided in such a door as shown in Figure 2.

(1) One opening of 40 square inches (unrestricted) as shown.

(2) Two 10 square inch openings (unrestricted) as shown.

**NOTE:** If screening, louvers or expanded metal are used to cover air openings, it must be remembered that such materials will restrict air flow. This restriction must be compensated for by making the actual air opening size proportionately larger. See "Compensating for Restrictions".

**NOTE:** If the generator is installed in a compartment, at least 1-1/2 inches of clearance must be provided between the generator and the compartment and any insulation or metal lining the compartment walls. Provide at least two (2) inches of clearance between the top of the generator and the compartment ceiling.

Figure 2. Air Inlet in Door

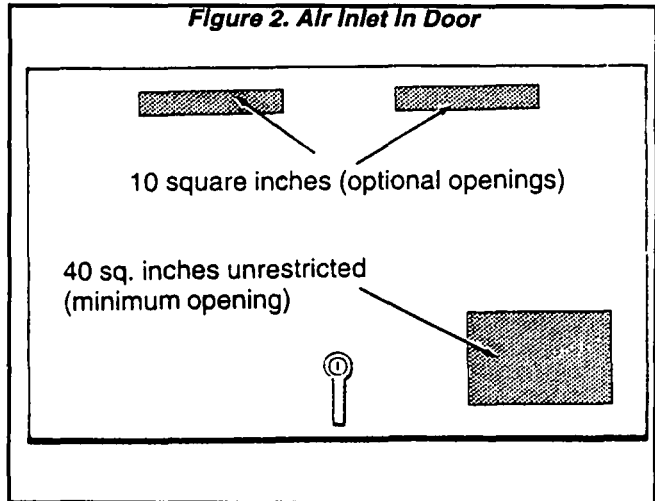

2. If the generator is suspended below the vehicle frame, any one of several methods can be used to supply required air flow.

a. A door in the vehicle skirt having the required air inlet openings (Figure 3).

b. By using ductwork. Air must be available at top of the engine-generator. See Figure 4.

c. By providing an opening in the vehicle skirt and at least 2 inches of space above the engine-generator (Figure 5).

### Compensating for Restrictions

Materials such as screening, louvers and expanded metal will restrict the free flow of air. When such materials are used to cover air openings, they must be compensated for by making the actual air opening size proportionately larger.

Some materials may offer only a 60 percent "free inlet area". More efficient materials may offer a 90 percent "free inlet area". The percentage of free air inlet opening can usually be obtained from the manufacturer of the material.

# Section 5.2- ENGINE COOLING SYSTEM

## Compensating for Restrictions (Continued)

**EXAMPLE:** Screening with an 80 percent free air inlet area is to be used to cover an opening that must be at least 40 square inches in area. Divide 40 by 0.80 to obtain 50 square inches. In this case, the actual opening size must be at least 50 square inches.

Figure 3. Door in Vehicle Skirt

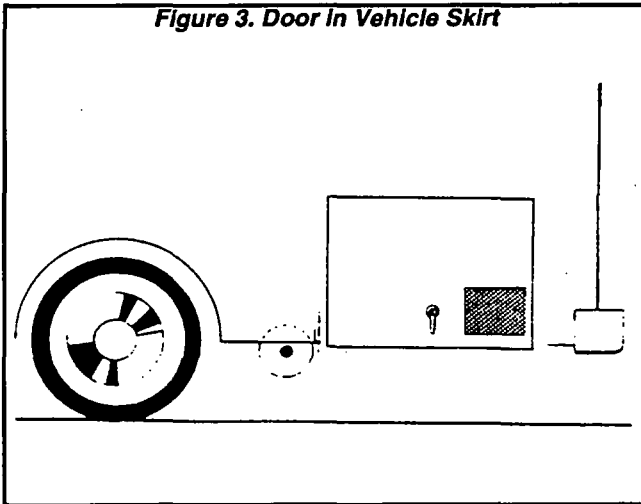

Figure 4. Ductwork

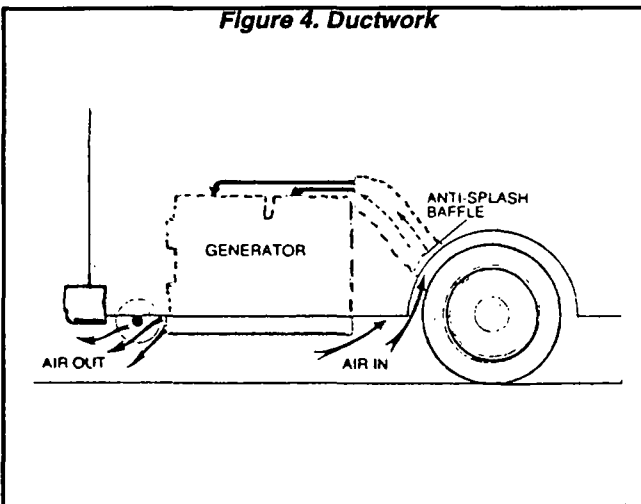
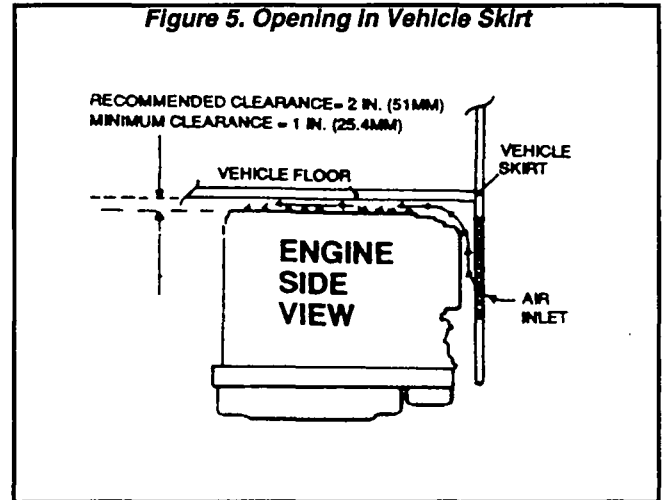

Figure 5. Opening in Vehicle Skirt



**Part 6**  
**ENGINE**  
**ELECTRICAL**  
**SYSTEM**

**COMPUTER**  
**CONTROLLED**  
**VARIABLE**  
**SPEED RV**  
**GENERATORS**  
Series NP-30G and NP-40G

<b>SECTION</b>	<b>TITLE</b>
6.1	ENGINE DC CONTROL SYSTEM
6.2	ENGINE CONTROLLER BOARD
6.3	ENGINE CRANKING SYSTEM
6.4	ENGINE IGNITION SYSTEM
6.5	ENGINE PROTECTIVE DEVICES
6.6	OPTIONAL REMOTE PANEL

# Section 6.1- ENGINE DC CONTROL SYSTEM

## General

The engine DC control system consists of all those electrical components required for cranking, starting and running the engine. These components include the following:

1. Engine cranking system components
  - a. A 12 VDC battery.
  - b. A Start-Run-Stop Switch (SW1).
  - c. A Starter Contactor (Starter Relay)- (SC).
  - d. A Starter Motor (SM).
2. An Engine Controller Circuit Board (ECB).
3. A Fuel Primer Switch (SW2).
4. Engine Ignition System Components.
  - a. Ignition Module (IM).
  - b. Ignition Stator (IS).
  - c. Ignition Coil (IC).
  - d. Spark Plug (SP).
5. Engine Protective Devices
  - a. Low Oil Pressure Switch (LOP).
  - b. High Oil Temperature Switch (HTO).
6. An optional Remote Panel.

**NOTE:** On units with LP gas fuel system, the Fuel Lockoff Solenoid (FS) will be turned on by closing the Primer Switch.

## CRANKING:

When the Start-Run-Stop Switch is held at "START", the Wire 17 circuit from the Engine Controller circuit board is connected to frame ground. Circuit board action then initiates the following events:

1. Battery voltage is delivered to the Starter Contactor (SC) coil via Wire 56.
  - a. The SC coil energizes and its contacts (SC) close.
  - b. Closure of SC contacts deliver battery voltage to the Starter Motor (SM) via Wire 16. The engine cranks.
2. Battery voltage is delivered to the Wire 14 circuit.
  - a. The Fuel Pump (FP) turns on.
  - b. Power is available to the Ignition Module (IM) and ignition occurs.

## How it Works

### ENGINE NOT RUNNING:

1. Battery output (12VDC) is available to the contacts of a starter contactor (SC). However, the contacts are open.
2. Battery output is delivered to Terminal J3 of an Engine Controller circuit board, via Wire 13, a 15 amp fuse, and Wire 15. Circuit board action holds this circuit open.
3. Battery output is available to a Battery Charge Rectifier (BCR) via Wire 13, 15 amp Fuse (F1), Wire 15, a Resistor (R2) and Wire 15A.

### PRIMING:

When the Primer Switch (SW2) is closed, battery voltage is delivered to the engine Fuel Pump via Wire 13, 15 amp Fuse (F1), the Switch contacts (SW2) and Wire 14A. The Fuel Pump will operate to draw fuel from the tank and "prime" the fuel lines.

Figure 1. Schematic- Engine DC Control System

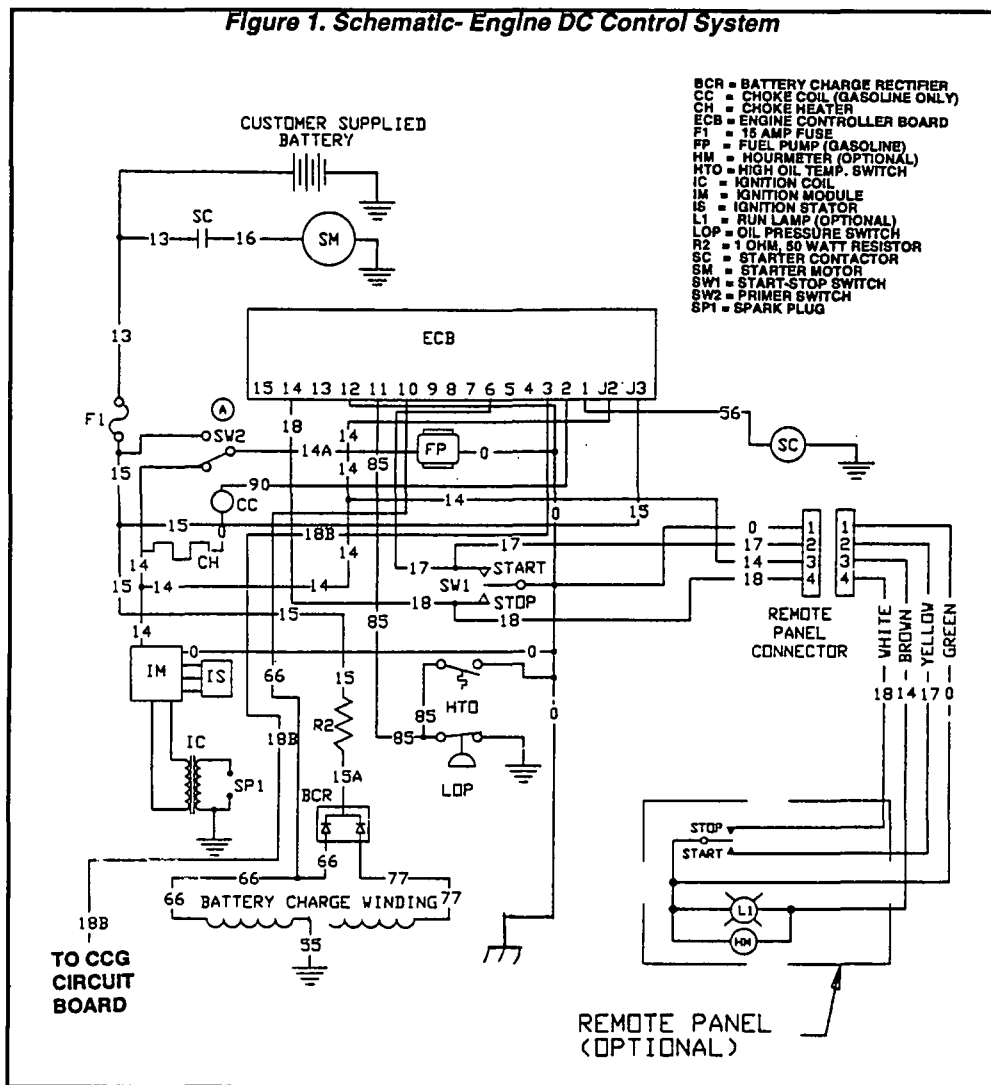

# Section 6.1- ENGINE DC CONTROL SYSTEM

---

## *How it Works (Continued)*

### CRANKING (CONT'D):

3. Engine Controller circuit board action operates the automatic choke.

*NOTE: Also see Section 3.5, "AUTOMATIC CHOKE" and Section 6.2, "ENGINE CONTROLLER BOARD".*

### RUNNING:

With fuel flow and Ignition available, the engine starts and runs. The operator releases the Start-Run-Stop switch to its "RUN" position.

1. The Wire 18 circuit is now open to ground. Circuit board action terminates the 12 VDC to the Starter Contactor (SC). The SC contacts open and cranking ends.
2. Choking action ends and the carburetor choke plate is positioned by the Choke Heater (CH).
3. Circuit board action continues to power the Wire 14 circuit- fuel flow and ignition continue.

### NORMAL SHUTDOWN:

When the Start-Run-Stop switch is held at "STOP", the Wire 18 circuit is connected to frame ground. Engine Controller circuit board action then terminates the DC flow to the Wire 14 circuit.

1. Fuel Pump (FP) shuts down.
2. Ignition terminates.
3. Engine shuts down.

*NOTE: Connection of the circuit board's Wire 18 or Wire 18B circuit to frame ground will always result in engine shutdown. Note that Wire 18B is routed to the CCG circuit board, giving that circuit board engine shutdown capability.*

### ENGINE PROTECTIVE DEVICE SHUTDOWN:

Refer to "Oil Filter Support" on Page 5.1-3 and Section 6.5. The engine mounts a Low Oil Pressure Switch (LOP) and a High Oil Temperature Switch.

# Section 6.2- ENGINE CONTROLLER BOARD

## General

The Engine Controller circuit board controls all phases of engine operation, including cranking, starting, running and shutdown.

The circuit board interconnects with other components of the engine electrical system to turn them on or off at the proper times.

The board is powered by fused 12 VDC battery output, available to the board via Wire 15.

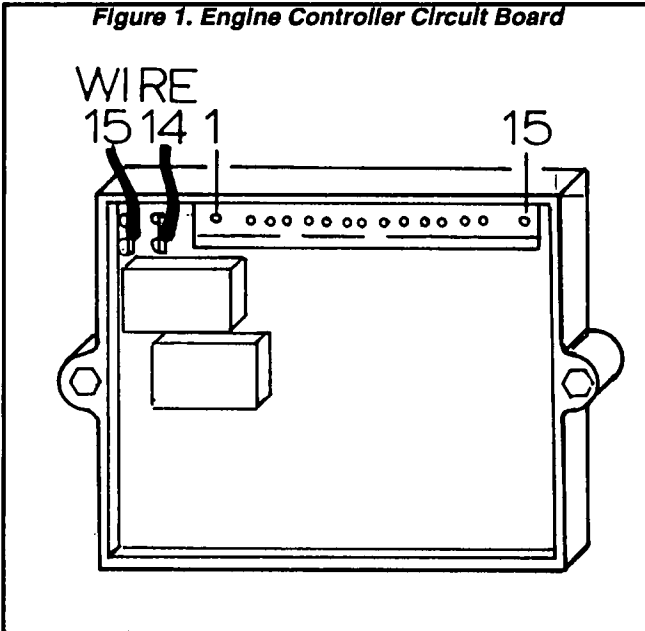

Figure 1. Engine Controller Circuit Board

## Circuit Board Connections

The circuit board mounts a 15-pin receptacle (J1). A 15-pin connector plug connects to this receptacle to interconnect the board with other components and circuits. In addition, a single pin terminal is provided on the board for connection of Wire 15 (J3) and a single pin terminal for Wire 14 (J2).

## Receptacle J1

This 15-pin receptacle is shown in Figure 2, along with a chart that identifies each pin, wire and function.

## Receptacle J2

Wire 14 connects to Terminal J2. This terminal and wire are electrically hot (12 volts DC) only when the engine is cranking or running. Battery voltage is delivered to Terminal J2 when circuit board action energizes a board-mounted run relay while cranking or running.

Wire 14 DC output is delivered to (a) the engine fuel pump and (b) the engine ignition system. If an optional remote panel is used, Wire 14 DC output will turn on a "RUN" lamp on that panel.

## Receptacle J3

Wire 15 connects to Terminal J3. This is fused battery voltage. The Wire 15 circuit is electrically hot at all times (provided the unit battery is connected).

Figure 2. Receptacle J1

PIN	WIRE	FUNCTION
1	56	Delivers 12 VDC to Starter Contactor while cranking only.
2	90	Delivers 12 VDC to automatic choke solenoid coil while cranking only.
3	18B	Interconnects CCG circuit board so that board can stop engine in the event of a generator fault (NOTE 1).
4	—	Not used on computer-controlled generator units.
5	—	Not used on computer-controlled generator units.
6	17	When Wire 17 is connected to ground by holding Start-Run-Stop switch at "START", cranking will occur.
7	—	Not used on computer-controlled generator units.
8	—	Not used on computer-controlled generator units.
9	—	Not used on computer-controlled generator units.
10	66	AC signal from Stator battery charge winding for starter cutout.
11	85	When grounded by Low Oil Pressure or High oil Temperature switch, the circuit board will stop engine.
12	0	Common frame ground.
13	—	Not used on Computer-controlled generator units.
14	18	When Wire 17 is connected to ground by holding Start-Run-Stop switch at "STOP", shutdown will occur.
15	—	Not used on computer-controlled generator units.

NOTE 1:- See "AUTOMATIC SHUTDOWNS" in Section 1.2 (Page 1.2-5).

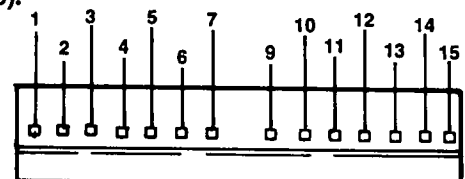

# **Section 6.2- ENGINE CONTROLLER BOARD**

---

# Section 6.3- ENGINE CRANKING SYSTEM

## Introduction

### COMPONENTS:

The engine cranking system is shown schematically in Figure 1, below. The system consists of the following components:

- A 12 volts Battery.
- A Start-Run-Stop Switch (SW1).
- A Starter Contactor (SC).
- A Starter Motor (SM).
- Engine Controller Circuit Board.
- Interconnecting wires.

### OPERATION:

1. Holding the Start-Run-Stop switch (SW1) at "START" connects Wire 17 from the Engine Controller board to frame ground.
  - a. Engine Controller board action energizes a crank relay on the board.
  - b. Closure of the crank relay's contacts delivers 12 VDC to Wire 56 and to a Starter Contactor (SC). The Starter Contactor (SC) energizes and its contacts close.
2. Closure of the the Starter Contractor (SC) contacts delivers battery voltage to the Starter Motor (SM). The Motor energizes and the engine is cranked.

and capable of delivering 360 cold-cranking amperes.

- For prevailing ambient temperatures below 32° F. (0° C.), use a battery rated 95 amp-hours and capable of delivering 450 cold-cranking amperes.

### BATTERY CABLES:

Battery cables should be as short as possible and of adequate diameter. Cables that are too long or too small in diameter can result in voltage drop. The voltage drop between battery terminals and the connection point at generator should not exceed 0.121 volts per 100 amperes of cranking current.

The cables should be carefully selected based on (a) cable length and (b) prevailing ambient temperatures. Generally, the longer the cable and the colder the ambient temperature, the larger the required cable size. The following chart applies:

CABLE LENGTH Feet (Meters)	CABLE SIZE
0 to 10 (0 to 3)	2*
11 to 15 (3.4-4.5)	0
16 to 20 (4.5 to 6)	000

\* For warm weather use No. 2 cable up to 20 feet.

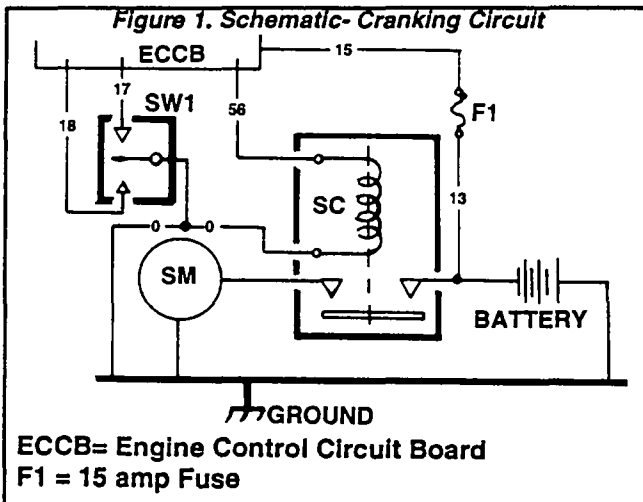

## Battery

### RECOMMENDED BATTERY:

The battery is generally supplied by the customer. Recommended is a battery that meets the following requirements:

- Use a 12 VDC automotive type storage battery.
- For prevailing ambient temperatures above 32° F. (0° C.), use a battery rated at 70 amp-hours

### BATTERY CABLE CONNECTIONS:

1. Connect the cable from the large Starter Contactor (SC) lug to the battery post indicated by a POSITIVE, POS or (+).
2. Connect the cable from its FRAME GROUND connection to the battery post indicated by a NEGATIVE, NEG or (-).

### TESTING A BATTERY:

The best method of testing a battery is with an automotive type battery hydrometer. Some "Maintenance Free" batteries cannot be tested with a hydrometer.

Most batteries can be tested for both STATE OF CHARGE and CONDITION as follows:

#### 1. Test for State of Charge:-

- a. Follow the hydrometer manufacturer's instructions carefully. Test the specific gravity of the fluid in all battery cells.
- b. If the hydrometer does not have a "Percentage of Charge" scale, compare the readings obtained with the following:

SPECIFIC GRAVITY	PERCENTAGE OF CHARGE
1.260	100%
1.230	75%
1.200	50%
1.170	25%



## Section 6.3- ENGINE CRANKING SYSTEM

### Battery (Continued)

#### TESTING A BATTERY (CONT'D):

If the battery State of Charge is less than 100%, use an automotive type battery charger to recharge it to a 100% State of Charge.

#### 2. Test for Condition:

- If the difference in specific gravity between the highest and lowest reading cell is greater than 0.050 (50 points), the battery is nearing the end of its useful life and should be replaced.
- However, if the highest reading cell is less than 1.230, recharge the battery and repeat the test.

### Start-Run-Stop Switch (SW1)

Wires 17 and 18 connect to the two outer terminals of the switch. Wire 0 (ground) connects to the switch center terminal.

The switch can be tested using a volt-ohm-milliammeter (VOM) as follows:

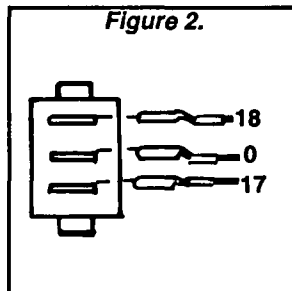

- Set the VOM to its "Rx1" scale and zero the meter.
- Connect the VOM test leads across the Wire 17 terminal and the center (Wire 0) terminals.
  - Hold the switch at "START" and the VOM should indicate "continuity".
  - Hold switch at "STOP" and meter should read "infinity".
- Now, connect the meter test leads across the center and Wire 18 terminals.
  - With switch at "START" VOM should indicate "infinity".
  - With switch at "STOP", meter should read "continuity".

Replace the switch if it is defective.

### Starter Contactor

#### WIRE AND CABLE CONNECTIONS:

The red (positive) battery cable connects to one of the starter contactor's large terminal lugs. The unit's 15 amp fuse also attaches to this lug, via Wire 13.

The starter motor (SM) cable (16) attaches to the second terminal lug.

Wire 56, from the engine controller circuit board, attaches to one of the small contactor terminals.

#### TESTING THE STARTER CONTACTOR:

To test the installed Starter Contactor, proceed as follows:

- Set a volt-ohm-milliammeter (VOM) to read battery voltage (12 VDC).
- Connect the VOM test leads across the Wire 56 terminal of the Contactor and frame ground. The meter should indicate "zero" volts.
- Hold the Start-Run-Stop switch at "START" and the VOM should read battery voltage and the Contactor should energize. After reading the voltage, release the switch. If battery voltage is NOT indicated, a problem exists elsewhere in the circuit.
- Connect the VOM test leads across the Wire 16 terminal lug and frame ground.
  - Hold the Start-Run-Stop switch at "START". The Contactor should actuate and the meter should indicate battery voltage.
  - If battery voltage is not indicated, replace the Starter Contactor.
  - If battery voltage is indicated but engine does not crank, check the Starter Motor and its cable.

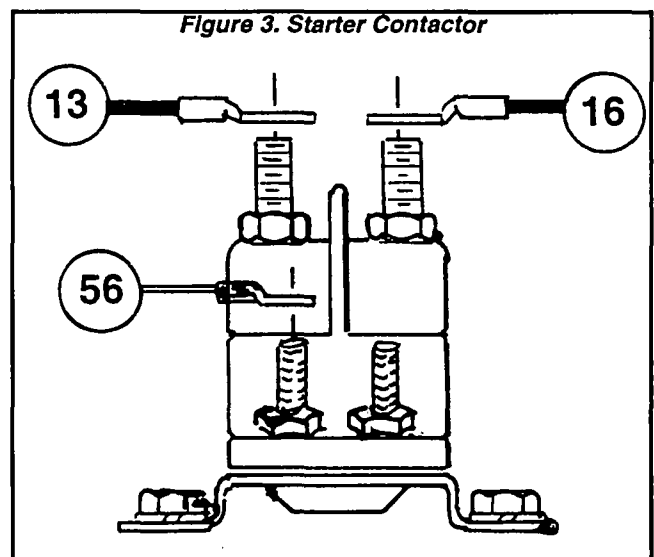

### Starter Motor

#### DESCRIPTION:

The Starter Motor is a 12 volts negative ground type. It is capable of operating on heavy duty battery input at temperatures as low as -30° F. without any significant change in performance. Its pinion is a 10-tooth type having a 20° pressure angle.

#### TESTING:

Connect the test leads of a VOM across the Starter Motor terminal and case. Hold the Start-Run-Stop switch at "START". The VOM should read battery voltage and the Starter Motor should turn.

If VOM reads 12 volts DC and the Motor does not turn, the Motor is probably defective. Remove the Motor and test with a 12 volts DC power source.

Replace the Starter Motor if defective.

## Section 6.3- ENGINE CRANKING SYSTEM

Figure 4. Starter Motor

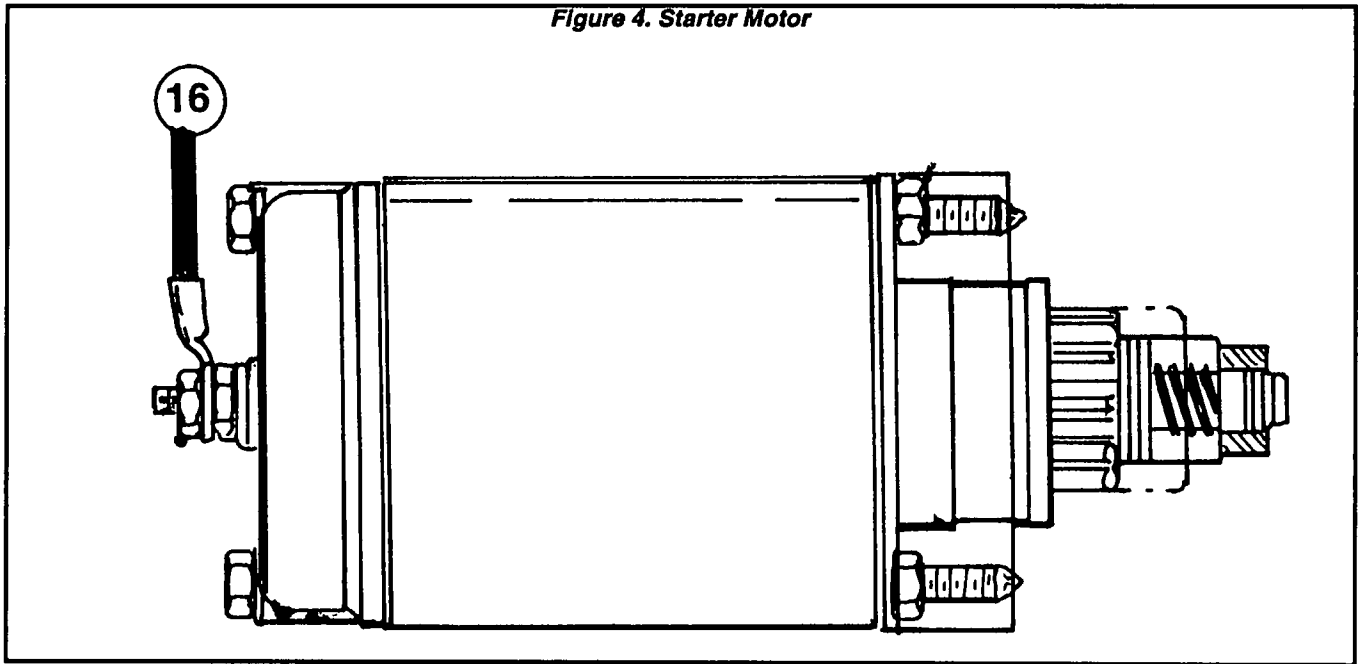

### ***Engine Controller Circuit Board***

Refer to Section 6.2.

# **Section 6.3- ENGINE CRANKING SYSTEM**

---

# Section 6.4- ENGINE IGNITION SYSTEM

## Introduction

The engine ignition system consists of the following major components:

- Ignition Cage Assembly.
- Ignition Sensor Assembly.
- Ignition Module (IM).
- Ignition Coil (IC).
- Spark Plug (SP1).

## Ignition Cage Assembly

An IGNITION CAGE ASSEMBLY is factory installed onto the permanent magnet rotor hub. Two magnets are installed in the cage as shown in Figure 1 (50° apart), so that the north pole of one magnet faces away from the cage outer periphery and the north pole of the other magnet faces toward the cage outer periphery. A special fixture is used to install the cage onto the rotor hub so that the center line of the first magnet is 68° away from the Rotor Hub mounting hole as shown.

**NOTE:** Placement of the magnets on the Rotor Hub at the exact position stated above results in an Ignition timing of 29° BTDC.

The Ignition Cage assembly cannot be replaced. The entire Rotor Hub must be replaced. Replacement Rotor Hubs will include a factory installed Ignition Cage assembly, and Magnetic Housing Assembly.

**NOTE:** Also refer to "Permanent Magnet Rotor" in Section 1.2 (Page 1.2-1).

Figure 1. Ignition Cage Assembly

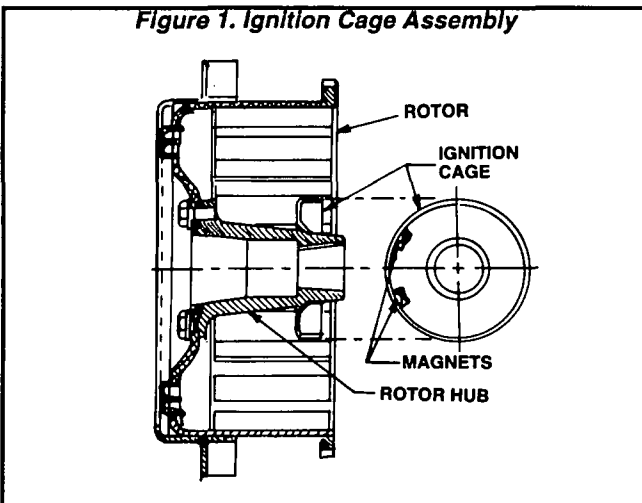

## Ignition Sensor

The Ignition Sensor is retained to the AC generator's Stator Adapter by means of two M4-0.70 x 8mm screws and lockwashers. The Sensor housing houses a circuit board. The entire housing cavity is filled with potting material.

As the generator's Permanent Magnet Rotor turns during operation, magnets on the Ignition Cage rotate past the Ignition Sensor to induce a timed low voltage pulse into the Sensor. This voltage pulse is delivered to an Ignition Module and serves as a timing pulse for the Module.

Figure 2. Ignition Sensor

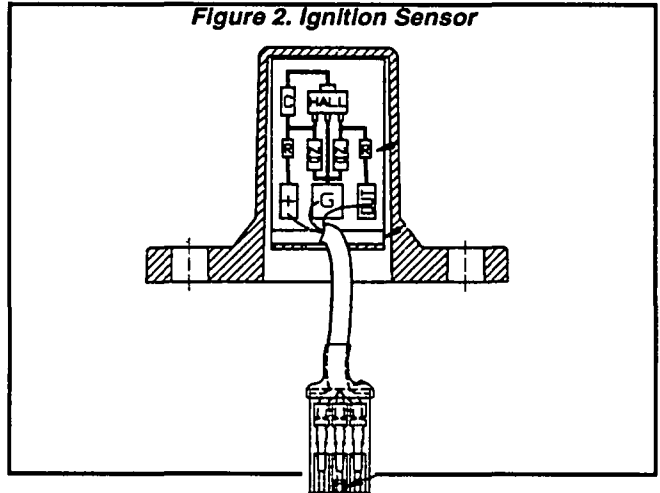

See Figure 3. The Sensor circuit board mounts solid state components which are sensitive to magnetism. Magnets in the Ignition Cage rotate past the Sensor, causing the base of a transistor to be "pulsed". The transistor acts much like a "switch" or a set of "contact points". Pulsing the transistor base causes the "switch" to close and connect the "OUT" lead to the "GND" lead. This triggers the Ignition Module to deliver a primary Ignition current to the Ignition Coil at timed intervals.

Figure 3. Ignition Sensor Schematic

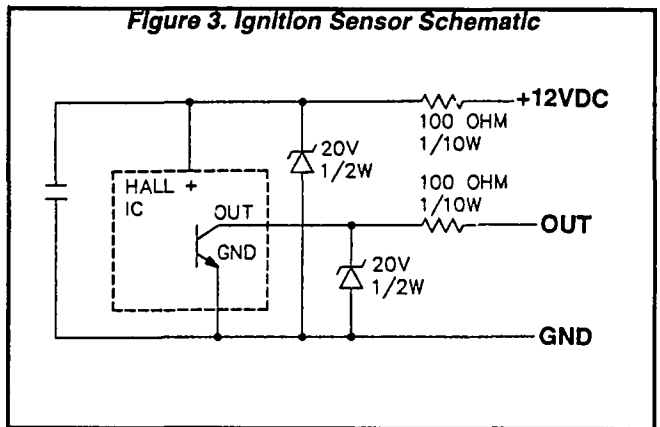

## Ignition Module

While cranking and running, battery voltage is delivered to the Ignition Module via Wire 14 from the Engine Controller circuit board. The Module will deliver this battery voltage to the Ignition Coil based on the "timing" signal it receives from the Ignition Sensor.

The Ignition Module is retained in the generator control panel by two capscrews.

# Section 6.4- ENGINE IGNITION SYSTEM

## Ignition Module (Continued)

Figure 4. Ignition Module

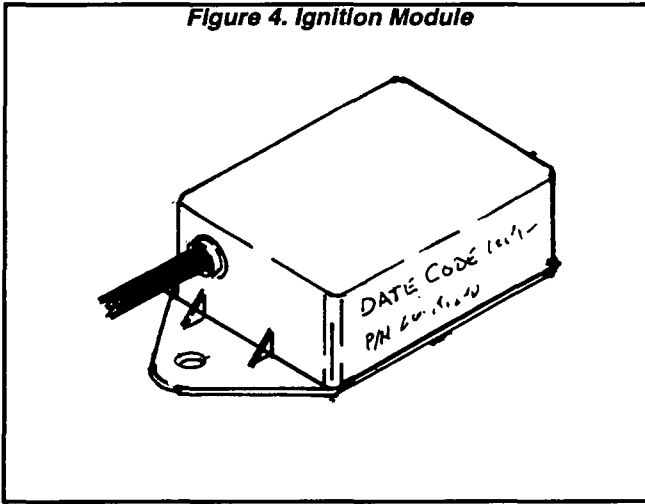

## Ignition Coil

Primary ignition voltage (12 VDC) is delivered from the Ignition Module to the Ignition Coil. The Coil boosts the voltage and delivers the high voltage to the engine Spark Plug.

Figure 5. Ignition Coil

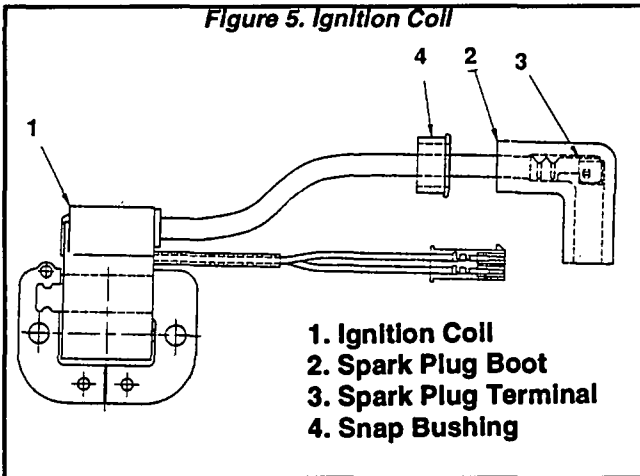

## Spark Plug

The Spark Plug on GN-190 and GN-220 engines is a Champion RC12YC (or equivalent).

Figure 6. Setting Spark Plug Gap

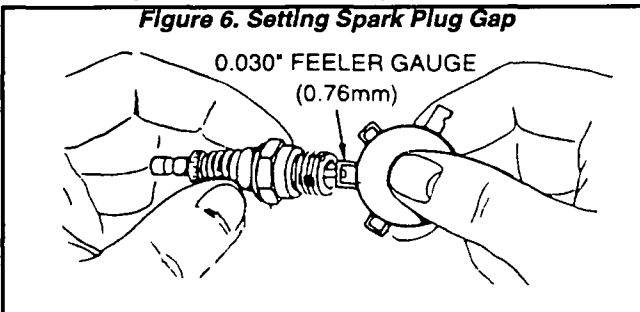

Clean the Spark Plug and reset its gap to 0.030 inch (0.76mm) every 100 hours of operation. Clean by scraping or wire brushing and washing with commercial solvent. DO NOT blast clean the spark plug.

## Summary of Operation

See Figure 6. As the generator's permanent magnet rotor turns, magnets in the Rotor hub's Ignition Cage rotate past an Ignition Sensor at fixed intervals.

Battery voltage is delivered to an Ignition Module during cranking and running, via Wire 14. From the Ignition Module, battery voltage is also delivered to the Ignition Sensor via the RED (+) lead. The Ignition Sensor acts as a "trigger" mechanism, causing the Ignition Module to deliver its output to the Ignition Coil at timed intervals. Current flows through the primary coil of the Ignition Coil and then collapses to induce a high voltage into the Ignition Coil's secondary coil. This high voltage (about 25,000 volts) is delivered to the Spark Plug to fire the spark plug gap.

Components encapsulated in the Ignition Module provide an automatic spark advance. At cranking speeds, ignition will occur at about 15°-18° BTDC. At higher speeds, ignition can occur up to 29° BTDC.

Figure 7. Ignition System Diagram

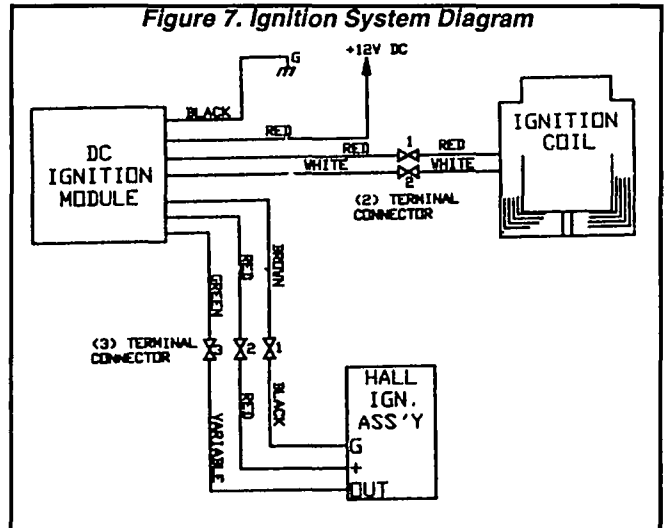

## Ignition Timing

Ignition timing is fixed and non-adjustable.

## Testing the System

### GENERAL:

Solid state components inside the Ignition Sensor, Ignition Module and Ignition Coil are not accessible and cannot be serviced. If any of these components is defective, the entire component must be replaced. The system does not include an armature and there is no air gap to adjust, or breaker points to adjust or replace.

## Section 6.4- ENGINE IGNITION SYSTEM

### TESTING FOR SPARK:

To test the Ignition system, a suitable spark tester may be used. Such spark testers are commercially available. Test the system as follows:

1. Disconnect the high tension lead from the spark plug.
2. Attach the spark plug high tension lead to the spark tester terminal.
3. Connect the spark tester clamp to the engine cylinder head.
4. Crank the engine rapidly. Engine must be turning at 350 rpm or more. If spark jumps the tester gap, you may assume the ignition system is operating satisfactorily.

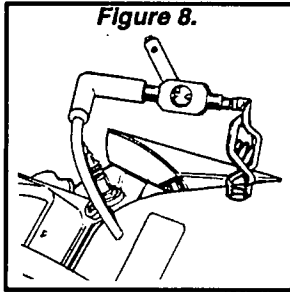

Figure 8.

If sparking across the tester gap does NOT occur, go to "CHECK POWER SUPPLY".

### CHECKING ENGINE MISS:

To determine if an engine miss is Ignition related, connect the spark tester in series with the spark plug's high tension lead and the spark plug. Then, start the engine. If spark jumps the tester gap at regular intervals but the engine miss continues, the problem is in the spark plug or in the fuel system.

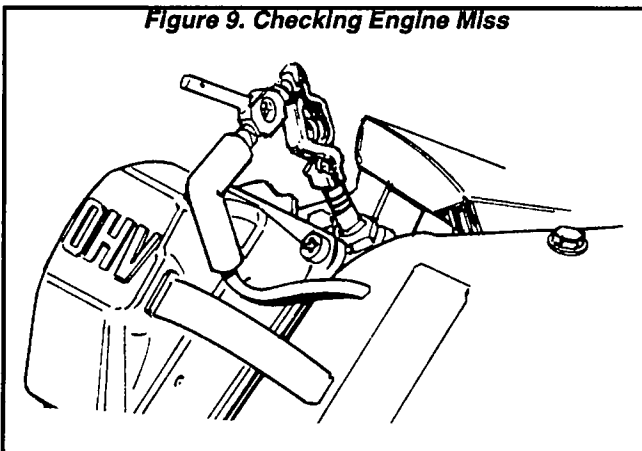

Figure 9. Checking Engine Miss

### CHECK POWER SUPPLY:

When the engine is being cranked, battery voltage should be available from the Engine Controller circuit board to a 4-terminal connector via Wire 14. From the 4-terminal connector, battery voltage should be available to the Ignition Module via Wire 14 (RED wire). And battery voltage should be available from the Ignition Module to the Ignition Sensor via a RED wire. If this 12 VDC power supply is not available, the Ignition system will not function. To check the power supply, proceed as follows using a volt-ohm-milliammeter (VOM):

1. Gain access to the control panel interior.
2. In the panel, locate the 3-pin connector that interconnects the Ignition Module and the Ignition Sensor.
3. Press down on the connector lock tang and disconnect the two connector halves.

**NOTE:** A single large black lead carries the three leads from the Ignition Sensor to the 3-pin MALE connector. The three leads from the Ignition Module (brown, green and red) attach to the 3-pin FE-MALE connector.

4. Set the VOM to a scale that will allow battery voltage to be read (about 12 volts DC).
5. Connect the meter test leads across the center FE-MALE pin (RED wire) and frame ground.
6. Hold the Start-Run-Stop switch at "START". The meter should read battery voltage.

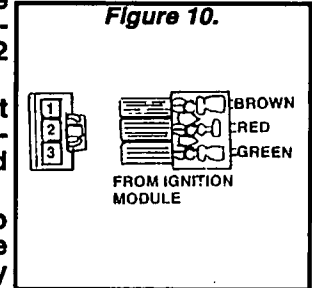

Figure 10.

If battery voltage is NOT indicated, go to Step 7. If battery voltage IS indicated, go to "CHECK IGNITION SENSOR".

7. Now locate the 4-terminal connector in the panel. Connect the VOM test leads across the terminal and frame ground. Crank the engine and the VOM should read battery voltage.

- a. If battery voltage is indicated now but was NOT indicated in Step 6, test Wire 14 (RED) between the 4-terminal connector and the Ignition Module. If wire is bad, repair or replace as necessary.
- b. If battery voltage is NOT indicated in Step 7, test Wire 14 between the 4-terminal connector and the Engine Controller circuit board. Repair or replace as necessary.

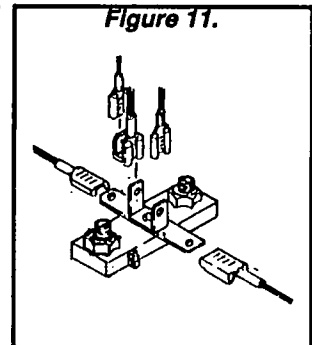

Figure 11.

### CHECK IGNITION SENSOR:

1. In the 3-pin connector plug half from the Ignition Module, locate FEMALE Pin 1 to which the BROWN wire connects.
2. Connect a jumper wire from FEMALE Pin 1 (BROWN wire) to frame ground.
3. Connect the Spark Plug high tension lead to a spark tester (Figure 8) and the spark tester clamp to ground.

# Section 6.4- ENGINE IGNITION SYSTEM

## Testing the System (Continued)

### CHECK IGNITION SENSOR (CONT'D):

4. Crank the engine and observe the spark tester for sparking.

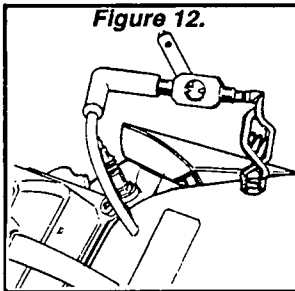

If sparking occurs with the BROWN wire grounded but did NOT occur under "TESTING FOR SPARK", the Ignition Sensor is probably defective and should be replaced.

**NOTE:** The Ignition Sensor is mounted to the generator's Stator Adapter. To replace the Sensor, disassembly of the generator and removal of the Stator will be necessary.

If sparking does NOT occur with the BROWN wire grounded and did NOT occur under "TESTING FOR SPARK", either the Ignition Module or the Ignition Coil is defective. Go to "TESTING IGNITION COIL".

### TESTING IGNITION COIL:

The Ignition Coil is housed in the generator control panel. To test the coil, proceed as follows:

1. Unplug the two halves of the 2-pin connector plug from the Ignition Coil. The red and white wires are the primary coil leads.
2. To read PRIMARY coil resistance:
  - a. Set a volt-ohm-milliammeter (VOM) to its "Rx1" scale and zero the meter.
  - b. Connect the VOM test leads across the two male pins of the 2-pin connector. Primary coil resistance should be about 0.5 to 1.5 ohms.
3. To read SECONDARY coil resistance:
  - a. Set the VOM to its "Rx10,000" or "Rx1K" scale and zero the meter.
  - b. Unplug the high tension lead from the Spark Plug.
  - c. Connect one VOM test lead to the white wire connector pin.
  - d. Connect the other VOM test lead into the Spark Plug lead rubber boot so it contacts the lead's metal terminal end. The VOM should read approximately 16,000-17,000 ohms (16.0-17.0 k-Ohms).

Replace the Ignition Coil if defective. If the Ignition Coil tested good, go to "TESTING IGNITION MODULE".

### TESTING IGNITION MODULE:

If a problem was indicated under "TESTING FOR SPARK", you should have completed the tests under "CHECK POWER SUPPLY", under "CHECK

IGNITION SENSOR" and under "TESTING IGNITION COIL". If these components tested good, replace the Ignition Module.

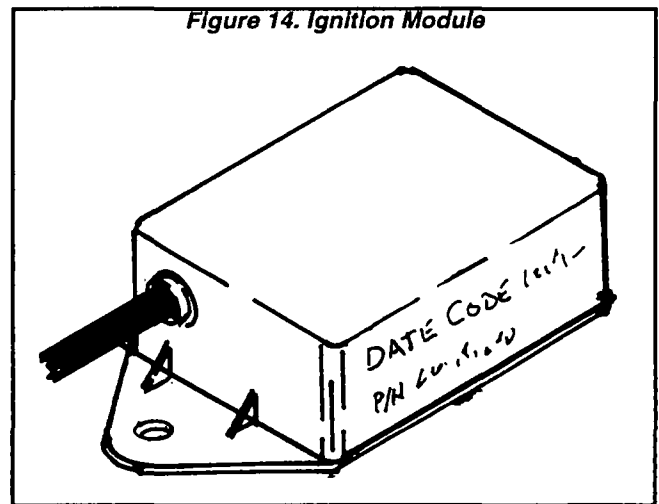
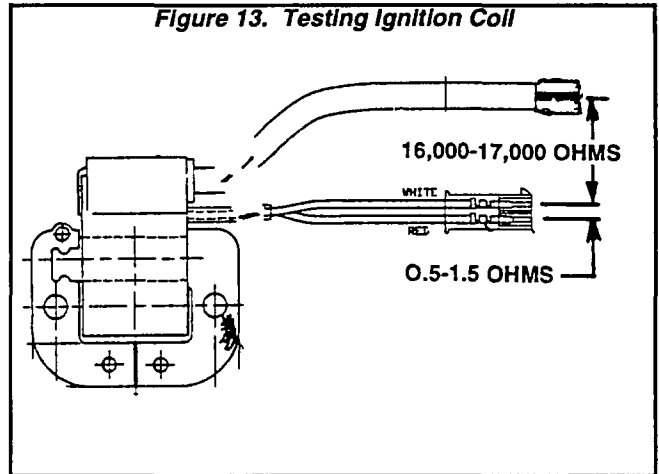

# Section 6.5- ENGINE PROTECTIVE DEVICES

## General

The engine mounts an Oil Pressure Switch (LOP) and an Oil Temperature Switch (HTO). These two switches, in conjunction with the Engine Controller circuit board, protect the engine against (a) low oil pressure and (b) high oil temperature.

The engine protective circuit is shown in Figure 1.

## Oil Pressure Switch

### DESCRIPTION:

The Oil Pressure Switch has normally-closed contacts which are held open by engine oil pressure during cranking and running. Should oil pressure drop below approximately 5 psi, the switch contacts will close to complete the Wire 85 circuit to ground. Engine Controller circuit board action will then de-energize the Wire 14 circuit and the engine will shut down.

The Engine Controller circuit board provides a time delay to allow oil pressure to build during startup, to prevent premature shutdown.

**NOTE:** Early production NP40G units were equipped with a Low Oil Switch rated 10 psi (Part No. 60108). Later production units are now equipped with a Low Oil Switch rated 5 psi (Part No. 77667). Units equipped with the 10 psi Switch must be retrofitted with the new 5 psi Switch (Part No. 77667).

### TESTING THE SWITCH:

Use a volt-ohm-millammeter (VOM) to test the oil pressure switch. Connect the VOM test leads across the switch terminal and the switch body. With the engine shut down, the meter should read "continuity" (a very small resistance is acceptable). With engine running, the meter should read "infinity".

## Oil Temperature Switch

### DESCRIPTION:

This thermostatic switch has normally-open contacts. Should engine oil temperature exceed a preset safe value (about 293° F.), the switch contacts will close. On closure of the Switch contacts, the Wire 85 circuit will be connected to frame ground. Engine shutdown will then occur.

**NOTE:** Early production NP40G units were equipped with an Oil Temperature Switch rated 265° F. That Oil Temperature Switch has been replaced on later production units by the 293° F. Switch (Part No. 94090). Early units having the 265° F. Switch may be subject to overtemperature shutdown and should be retrofitted with the new 293° F. Switch.

Figure 1. Engine Protective Circuit

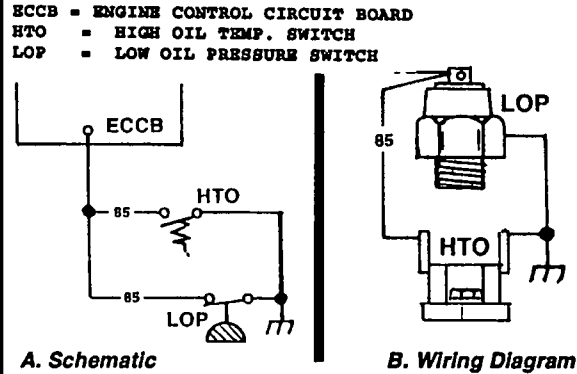

Figure 2. Engine Protective Devices

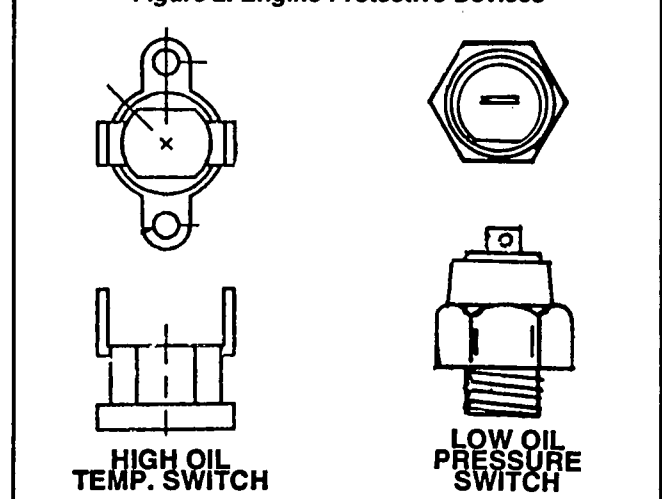
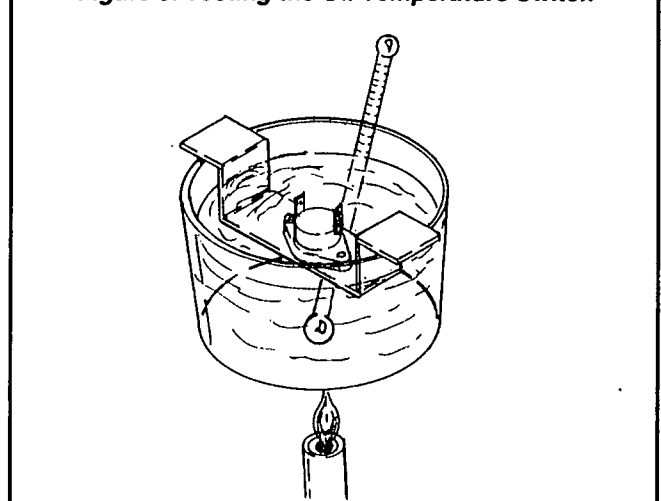

Figure 3. Testing the Oil Temperature Switch





## Section 6.5- ENGINE PROTECTIVE DEVICES

---

### *Oil Temperature Switch (Continued)*

**NOTE:** *The CCG circuit board also has automatic engine shutdown capability. The circuit board will shut the engine down automatically on occurrence of (a) over-voltage, (b) under-voltage, (c) over-speed, (d) zero current failure, (e) converter failure, or (ef) micro-processor failure. See Section 1.2.*

#### **TESTING:**

See Figure 3. Remove the switch and place its sensing tip into oil. Place a thermometer into the oil. Connect the test leads of a VOM across the switch terminals. The meter should read "Infinity". Heat the oil. When oil temperature reaches approximately 287°-296° F. (142°-147° C.), the meter should read "continuity" (a small resistance is acceptable).

**NOTE:** *The above procedure applies to Oil Temperature Switch Part No. 94090, rated 293° F. (145° C.). Some early production units were equipped with a 265° F. switch which caused premature high temperature shutdowns. The 265° F. switch should be removed and replaced with the Part No. 94090 switch.*

# Section 6.6- OPTIONAL REMOTE PANEL

## General

An optional remote-mounted Start-Stop panel is available. This panel will permit the generator to be started and stopped from some convenient remote location in the recreational vehicle.

## Remote Panel Cables

The generator is equipped with a 4-pin receptacle for connection of the remote panel. Cables are available which mate with the receptacle and interconnect the generator with the remote panel.

- Cable Model 9045 is a 10 foot long, 4-wire cable.
- Cable Model 9046 is a 30 foot long, 4-wire cable.

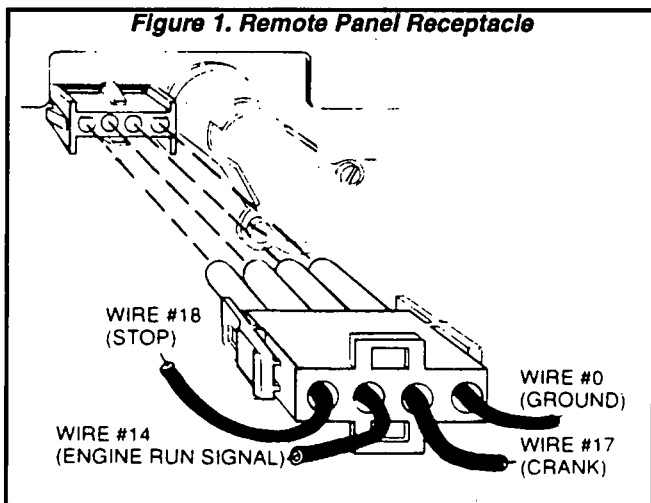

## Description

### MODEL 9042:

The Model 9042 remote panel mounts a rocker type Start-Run-Stop switch and a "GEN. RUN" advisory lamp. The lamp is turned on by Wire 14 current when the generator is running.

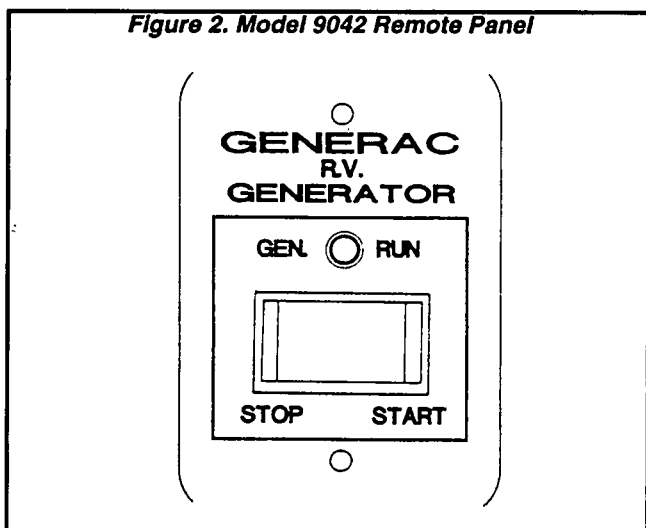

### MODEL 9043:

The Model 9043 remote panel mounts a rocker type Start-Run-Stop switch, a "GEN. RUN" lamp and an hourmeter.

The "GEN. RUN" lamp will turn on when the engine is running. It is turned on by Wire 14 power.

The Hourmeter provides a continuous indication of generator operating hours in hours and tenths of hours. It can be used in conjunction with the required periodic maintenance on the unit.

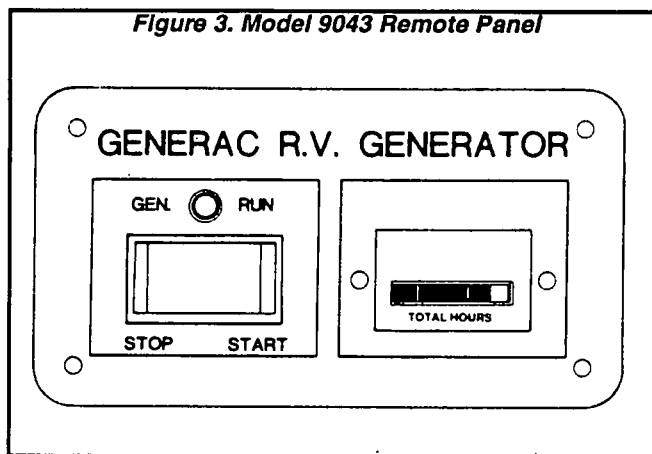

## Wiring Connections

Wiring connections for the remote panel are shown in Figure 4.

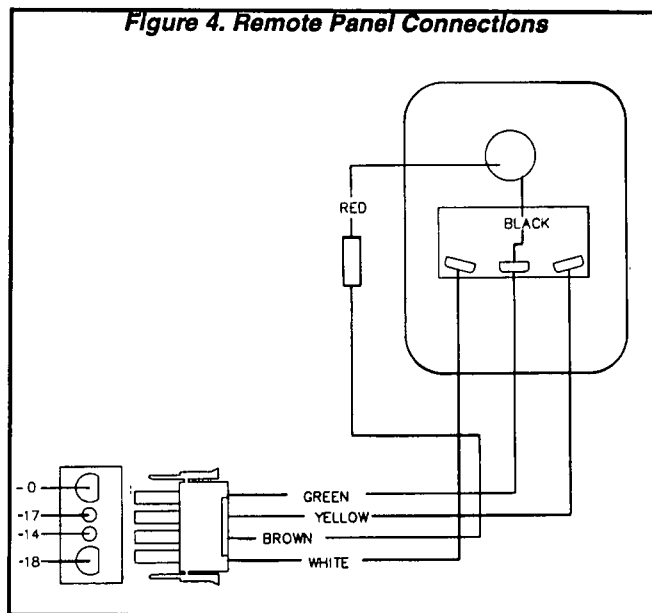

# **Section 6.6- OPTIONAL REMOTE PANEL**

---

**Part 7**  
**TROUBLE-**  
**SHOOTING**

**COMPUTER  
CONTROLLED  
VARIABLE  
SPEED RV  
GENERATORS**  
Series NP-30G and NP-40G

<b>SECTION</b>	<b>TITLE</b>
7.1	<b>GENERATOR &amp; SPEED CONTROL</b>
7.2	<b>ENGINE DC CONTROL SYSTEM</b>

# Section 7.1- GENERATOR & SPEED CONTROL SYSTEM

## Troubleshooting Reference Chart

PROBLEM	POSSIBLE CAUSE	REMEDY	SEE PAGE
1. Engine starts, accelerates, shuts down at 4500 rpm	a. Carburetor linkage sticking with throttle stuck open. b. Stepper Motor failed or seized. c. Stepper Motor wire connections broken or disconnected. d. Stepper Motor not properly connected.	a. Repair sticking throttle b. Replace Stepper Motor. c. Reconnect or repair. d. Reconnect wires.	3.4-3 3.6-1 3.6-1 3.6-1
2. Overvoltage condition and speed control system cannot reduce output voltage.	a. Carburetor linkage sticking with throttle stuck partly open. b. Stepper Motor failed or seized. c. Connection to Stepper Motor is broken/disconnected with throttle open. d. Stepper Motor not properly connected.	a. Repair sticking throttle. b. Replace Stepper Motor. c. Repair or replace connections. d. Reconnect Stepper Motor wires.	3.4-3 3.6-1 3.6-1 3.6-1
3. Engine speed is maintained and no-load voltage is good. However, when load is applied output voltage drops and engine shuts down.	a. Carburetor linkage sticking with throttle partly open. b. Stepper Motor failed or seized. c. Connection to Stepper Motor broken or disconnected. d. Stepper Motor not properly connected.	a. Repair sticking throttle. b. Replace Stepper Motor. c. Repair or replace connections. d. Reconnect Stepper Motor.	3.4-3 3.6-1 3.6-1 3.6-1
4. Engine does not accelerate when load is applied. After 10 seconds, engine shuts down.	a. Carburetor linkage sticking with throttle stuck closed. b. Stepper Motor failed or seized. c. Stepper Motor not properly connected.	a. Repair sticking throttle. b. Replace Stepper Motor. c. Reconnect Stepper Motor.	3.4-3 3.6-1 3.6-1
5. Engine speed and AC output voltage erratic under constant load. AC output does not turn off intermittently.	a. Stepper Motor failure. b. Connection to Stepper Motor broken or disconnected. c. Stepper Motor not properly connected. d. CCG board failure (erratic detection of "zero voltage" crossings).	a. Replace Stepper Motor. b. Repair or replace connections. c. Reconnect Stepper Motor. d. Replace CCG Circuit Board.	3.6-1 3.6-1 3.6-1 1.5-4
6. Engine starts but Stepper Motor does not move. Shut down occurs after several seconds.	a. Power Supply winding (PS1, PS2) is open. b. Stator Timing winding is open. c. Power supply winding in Stator shorted to ground (See NOTE 1). d. Timing winding in Stator shorted to ground. e. CCG board does not detect "Zero Voltage" crossings.	a. Repair or replace bad wire(s) PS1/PS2 or replace Stator. b. Repair/replace bad wire(s) TIM1/TIM2 or replace Stator. c. Replace Stator. d. Replace Stator. e. Replace CCG circuit board.	1.5-2 1.5-2 1.5-2 1.5-2 1.5-4
7. Engine shuts down but over-speed above 4500 rpm did not occur.	a. One of four power windings in Stator is open. b. Main windings shorted to ground. c. Bad switch in Genistor. d. No gate connection between CCG board and Genistor. e. No connection between Genistor and Stator (AC1, AC2, SL1, SL2) f. CCG board failure.	a. Repair/replace bad wire(s) AC1/AC2 or SL1/SL2 or replace Stator. b. Replace Stator. c. Replace Genistor. d. Repair/replace bad wire(s) or replace bad CCG circuit board. e. Repair or replace connecting wire(s). f. Replace CCG circuit board.	1.5-1 1.5-1 1.5-3 1.5-4 1.5-3 1.5-4
8. AC output turns off intermittently. Then, engine runs at idle for 5 seconds. Finally, AC turns back on and unit runs normally.	a. CCG board failure.	a. Replace CCG circuit board.	1.5-4
9. Under heavy load, output turns off and engine speed drops to idle.	a. CCG circuit board failure.	a. Replace CCG circuit board.	1.5-4
NOTE 1- Shorted power supply windings may cause circuit board ground trace to show evidence of burning.			

# Section 7.1- GENERATOR & SPEED CONTROL SYSTEM

# Section 7.2- ENGINE DC CONTROL SYSTEM

## Introduction

This Section contains troubleshooting information pertaining to the engine DC control system. The section is divided into two parts, i.e., troubleshooting flow charts and diagnostic test procedures.

Use the flow charts and the test procedures in conjunction with one another. The first step in troubleshooting is to identify the problem. After identifying the problem, go to the flow chart that best describes it. Perform each test in the flow chart and follow the flow chart arrows and instructions. If you need instructions for any test, refer to the applicable diagnostic test procedure.

Problem solving on the computer controlled generator is somewhat more complex than problem solving on conventional units, for the following reasons:

- The CCG circuit board, in addition to its voltage and frequency control functions, has engine shutdown capability. See "AUTOMATIC SHUT-DOWNS" on Page 1.2-5. The Engine Controller board, part of the engine's DC control system, also has engine shutdown capability.
- The CCG circuit board, in conjunction with the Stepper Motor, controls engine throttle setting as a means of voltage control. It may be difficult to differentiate between the computer or DC control system as the cause of a problem.

Fortunately, neither the generator proper nor the engine DC control system has a large number of parts. When a problem is encountered, its solution can usually be found after only a few tests.

### Problem 1- Priming Function Does Not Work

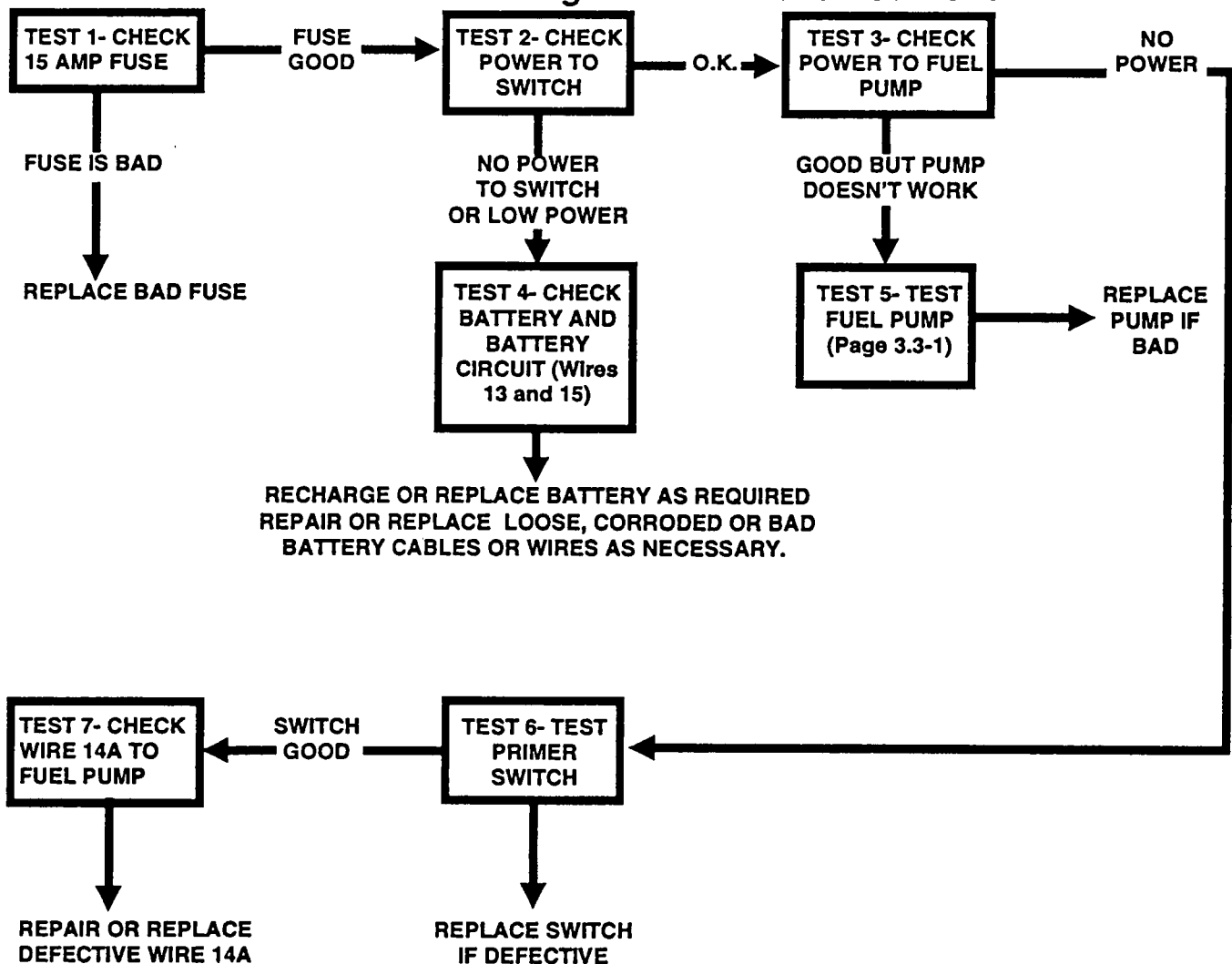

# Section 7.2- ENGINE DC CONTROL SYSTEM

## Problem 2- Engine Will Not Crank

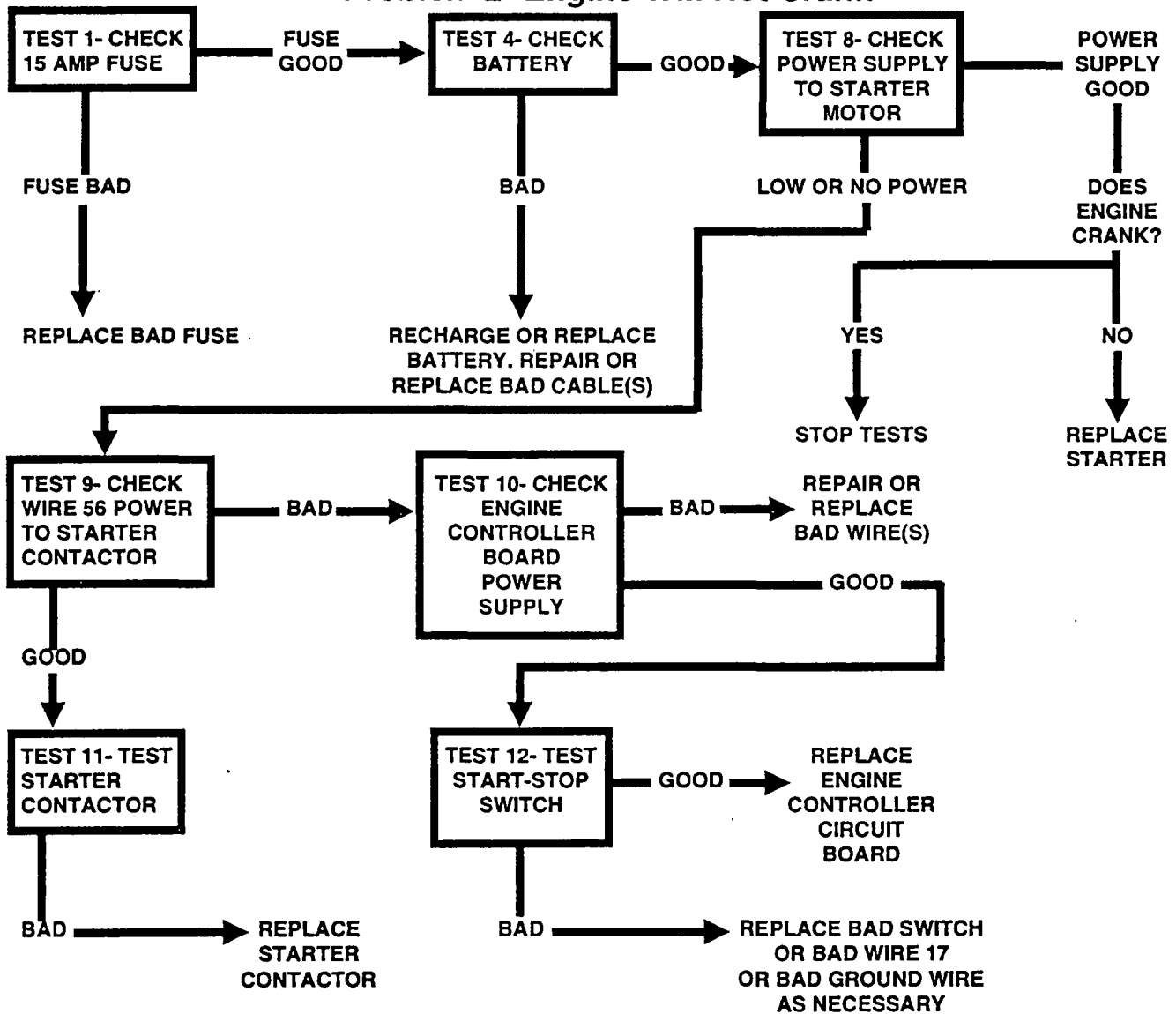

## Problem 3- Engine Cranks But Will Not Start

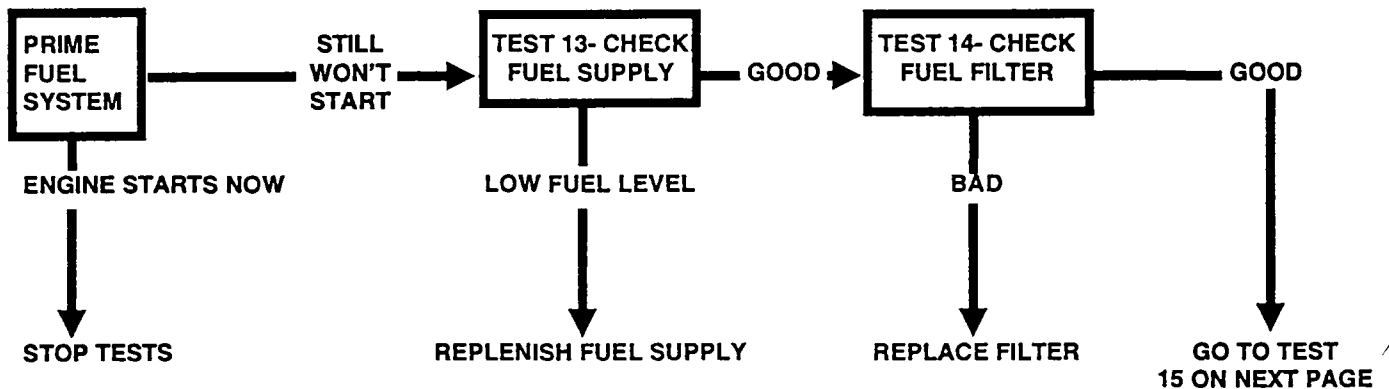



# Section 7.2- ENGINE DC CONTROL SYSTEM

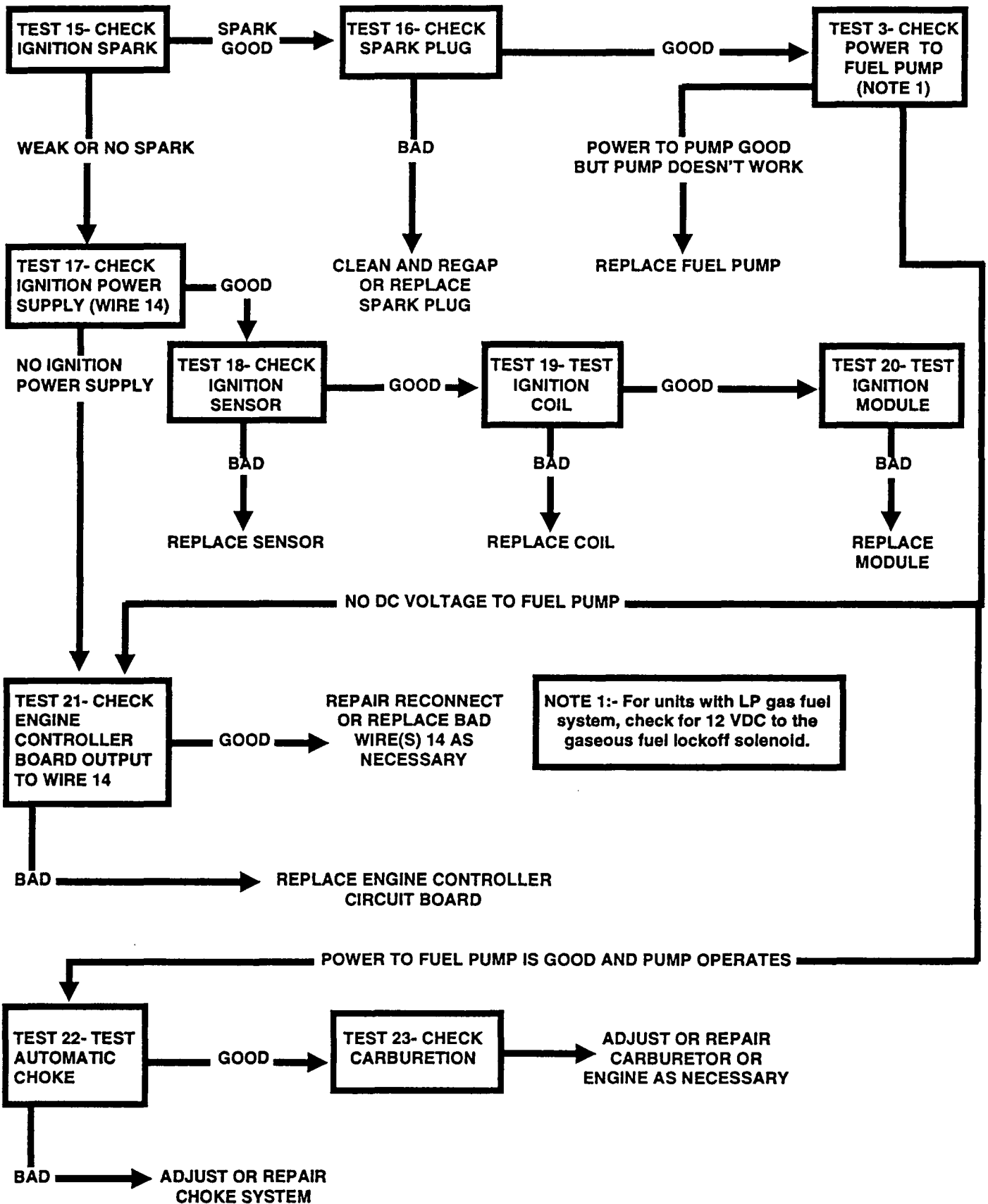

# Section 7.2- ENGINE DC CONTROL SYSTEM

## Problem 4- Engine Starts Hard and Runs Rough

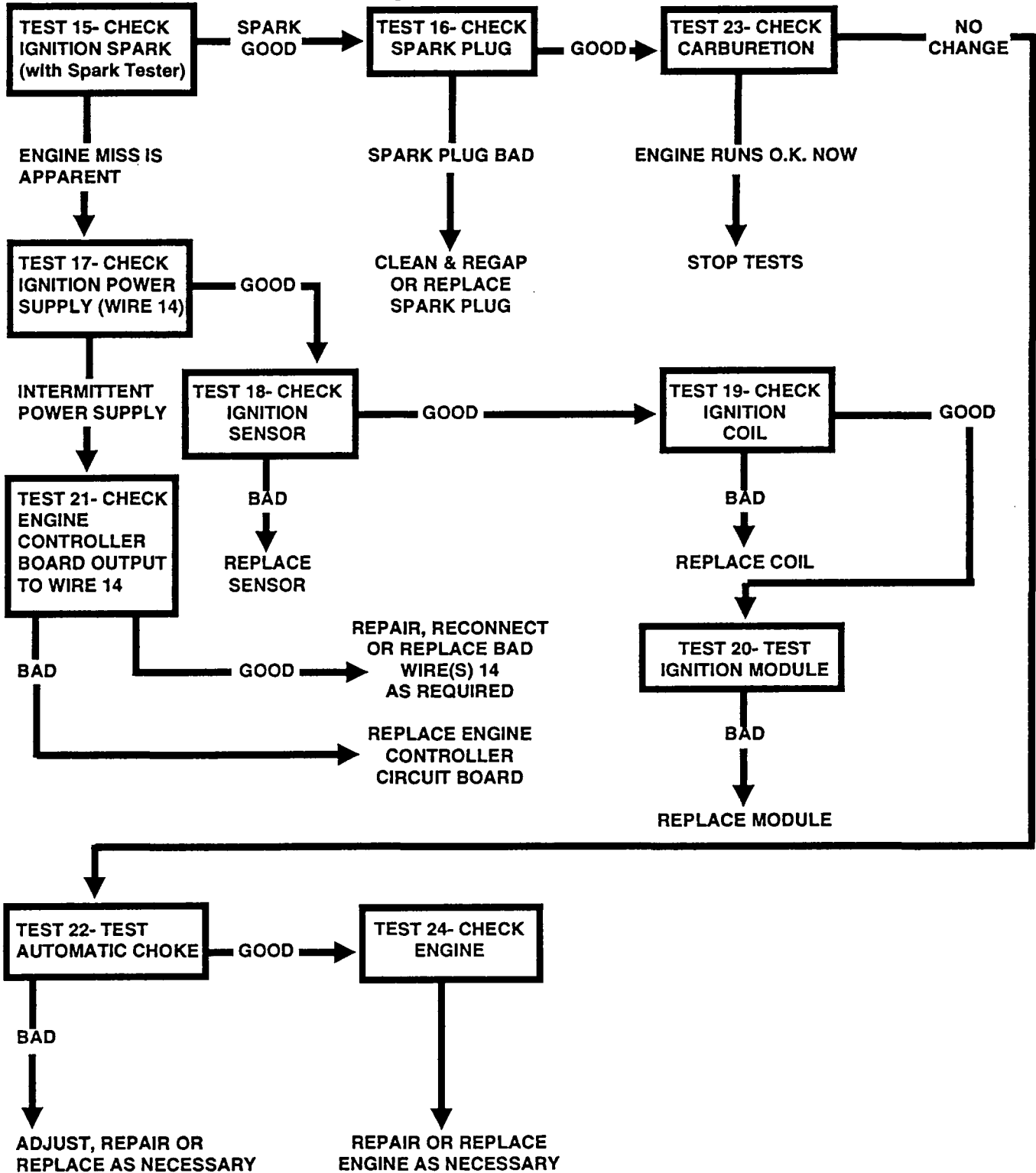

## Section 7.2- ENGINE DC CONTROL SYSTEM

### Problem 5- Engine Starts Then Shuts Down After a Few Seconds

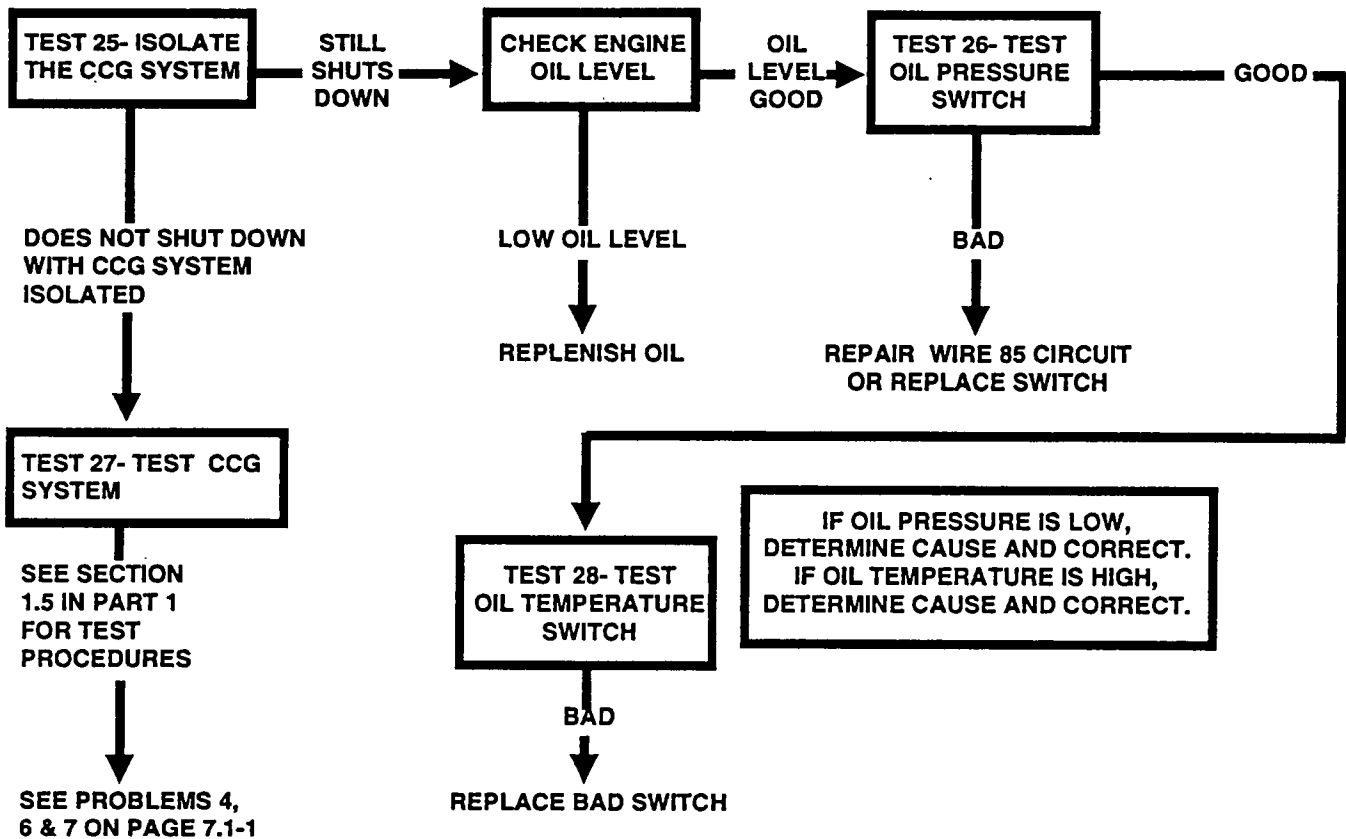

# Section 7.2- ENGINE DC CONTROL SYSTEM

## Test 1- Check 15 Amp Fuse

### DISCUSSION:

The panel-mounted 15 amp fuse is connected in series with the 12 VDC power supply to the engine DC control system. A blown fuse will prevent engine priming, cranking and running.

### TEST PROCEDURE:

Push in on fuse holder cap and turn it counterclockwise to remove cap and fuse. Check the fuse visually. If the fuse metal element has melted open, replace the fuse.

If the visual check is uncertain, use a VOM to check fuse.

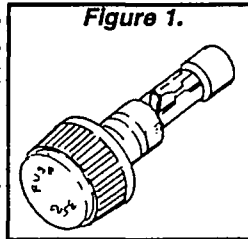

### RESULTS:

1. If fuse is good
  - a. And if priming function does not work, go to Test 2.
  - b. And if engine will not crank, go to Step 4.
2. If fuse is bad, replace it.

## Test 2- Check Power to Switch

### DISCUSSION:

This is a check of the PRIMER SWITCH on the panel. When the switch is actuated to its "PRIME" position, fused battery voltage is delivered directly to the electric fuel pump on units with gasoline fuel system. On units with gaseous fuel system, battery voltage is delivered to the fuel lockoff solenoid.

### TEST PROCEDURE:

Set a VOM to read battery voltage (12 VDC). Connect the meter test leads across the Wire 15 terminal of the Primer Switch and frame ground. The meter should read battery voltage.

### RESULTS:

1. If battery voltage is indicated, go to Test 3.
2. If battery voltage is NOT indicated, go to Test 4.

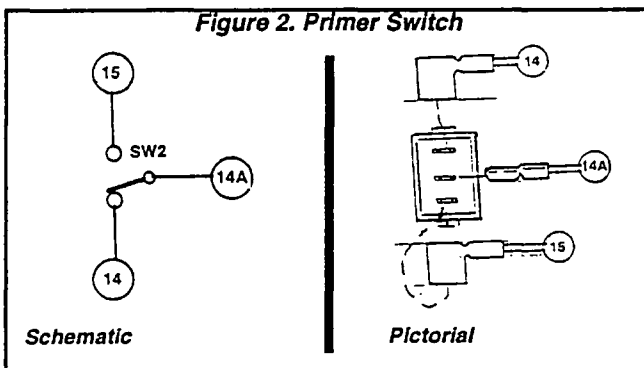

## Test 3- Check Power to Fuel Pump

### DISCUSSION:

When the rocker type primer switch is held at "ON", position, fused battery voltage is delivered to the electric fuel pump. The pump should then turn on and prime the carburetor.

During cranking and startup, the engine controller circuit board will deliver battery voltage to the Wire 14 circuit and to the Fuel Pump. The pump should turn on and run.

### TEST PROCEDURE:

Locate the red Wire 14A that connects to the fuel pump. A wiring connector connects the wires near the pump. Separate the wire, then check for DC power as follows:

1. Set VOM to read battery voltage.
2. Connect the VOM test leads across the Wire 14A from the Primer Switch and frame ground.
3. Hold the Primer Switch at "ON" (Prime). Meter should read battery voltage.
4. Hold the panel Start-Run-Stop switch at "START". The meter should read battery voltage.

### RESULTS:

1. If unit is being tested because the priming function doesn't work:
  - a. If battery voltage is good but the pump doesn't work, go to Test 5.
  - b. If battery voltage is NOT indicated, go to Test 6.
2. If engine cranks but will not start:
  - a. If battery voltage is good but pump doesn't work, go to Test 5.
  - b. If DC power to pump is good and pump works, go to Test 22.

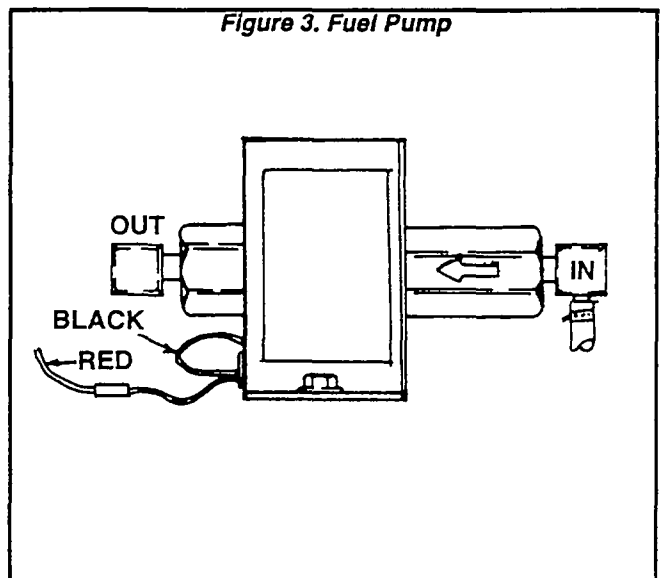

## Section 7.2- ENGINE DC CONTROL SYSTEM

### *Test 4- Check Battery/Battery Circuit*

#### DISCUSSION:

The battery circuit includes the red battery cable that extends from the units 12 volt battery to the Starter Contactor. The circuit also includes Wire 13 (RED) from the Starter Contactor to the 15 amp Fuse. It includes one Wire 15 from the Fuse to the Primer Switch and a Wire 15 from the Fuse to the Engine Controller circuit board.

#### TEST PROCEDURE:

Inspect the battery terminals and cables carefully. Clean cables and cable connections if necessary. Replace any bad cable(s), including the battery negative cable, if necessary.

Check Wires 13 and 15 for an open or shorted condition. Repair, reconnect or replace bad wire(s) as necessary.

Use a battery hydrometer to test the battery for "state of charge" and for "condition". Follow the hydrometer manufacturer's instructions carefully. If the hydrometer used does not have a "percentage of charge" scale, use the following as a reference:

SPECIFIC GRAVITY	PERCENTAGE OF CHARGE
1.260	100%
1.230	75%
1.200	50%
1.170	25%

#### RESULTS:

1. Repair, reconnect or replace any open or shorted wire(s).
2. If necessary, recharge the battery to a 100% state of charge. Disconnect the battery cables before recharging the battery.
3. If (after recharging) the difference in specific gravity between the highest and lowest reading cells is greater than 0.050 (50 points) the battery is nearing the end of its useful life and should be replaced.

### *Test 5- Test Fuel Pump*

Refer to Page 3.3-1.

### *Test 6- Test Primer Switch*

#### DISCUSSION:

See Figure 2 on facing page. When this rocker type switch is held at "PRIME" position, fused battery voltage is delivered to the Fuel Pump to prime the carburetor.

With the switch set to "OFF", battery voltage is delivered to the Fuel Pump from the Engine Controller board during cranking and running (via Wire 14).

#### TEST PROCEDURE:

1. Disconnect Wires 15, 14 and 14A from the switch terminal to prevent interaction.
2. Set a VOM to its "Rx1" scale and zero the meter.
3. Connect the VOM test leads across the Wire 15 terminal and the Wire 14A terminal. The meter should read "infinity". Set the switch to "ON" or "PRIME" and the meter should indicate "continuity".
4. Connect the VOM test leads across the Wires 14 and 14A terminals. The meter should read "continuity". Set the switch to "ON" or "PRIME" and the VOM should read "infinity".

#### RESULTS:

1. Replace switch if it fails the test.
2. If the switch is good, go to Test 7.

### *Test 7- Check Wire 14A to Fuel Pump*

#### DISCUSSION:

If no power was available to the Fuel Pump in Test 3, either the Primer Switch is defective or Wire 14A is open.

#### TEST PROCEDURE:

Inspect Wire 14A between the fuel pump and primer switch for proper connections. Check for open condition with a VOM.

#### RESULTS:

Repair, reconnect or replace Wire 14A as necessary.

### *Test 8- Check Power Supply to Starter Motor*

#### DISCUSSION:

When the Start-Run-Stop switch is set to "START", Wire 17 is connected to ground. Engine Controller circuit board action then delivers a DC voltage to the Starter Contactor coil and the Contactor's normally-open contacts close. On closure of the contacts, battery power is delivered directly to the Starter Motor to crank the engine.

This test will determine if battery voltage is available to the Starter Motor for cranking the engine.

#### TEST PROCEDURE:

1. Set a VOM to read battery voltage (12 VDC).
2. Connect the meter test leads across the starter terminal and frame ground.
3. Hold the Start-Run-Stop switch at "START". The VOM should read battery voltage and the engine should crank.

## Section 7.2- ENGINE DC CONTROL SYSTEM

### Test 8- Check Power Supply to Starter Motor (Continued)

#### RESULTS:

1. If power supply is good and engine cranks, stop tests.
2. If power supply is good but engine does NOT crank, replace the Starter.
3. If power supply is bad, go on to Test 9.

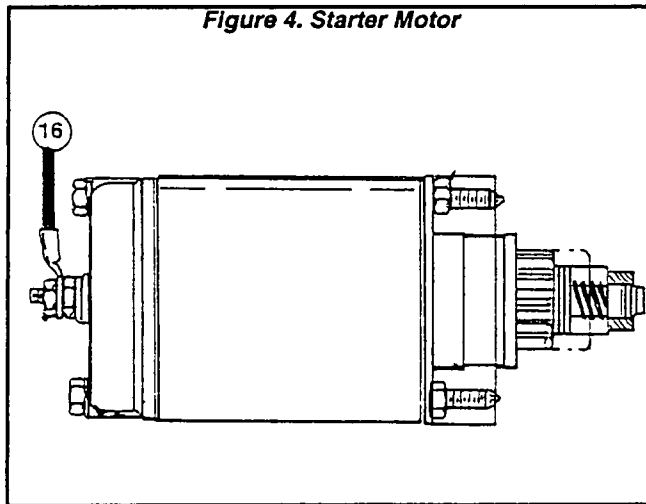

### Test 9- Check Wire 56 Power to Starter Contactor

#### DISCUSSION:

When the Start-Run-Stop switch is set to "START", the Engine Controller circuit board must react by delivering battery voltage to the Starter Contactor coil, via Wire 56. Without this battery voltage, the Contactor will not energize and battery output will not be delivered to the Starter Motor. The engine will not crank.

#### TEST PROCEDURE:

1. Set a VOM to read battery voltage (12 VDC).
2. Connect the meter test leads across the Wire 56 starter contactor terminal and frame ground.
3. Set the Start-Run-Stop switch to "START". The meter should indicate battery voltage.

#### RESULTS:

1. No power to Wire 56 terminal, go to Test 10.
2. If power to Starter Contactor is good, go to Test 11.

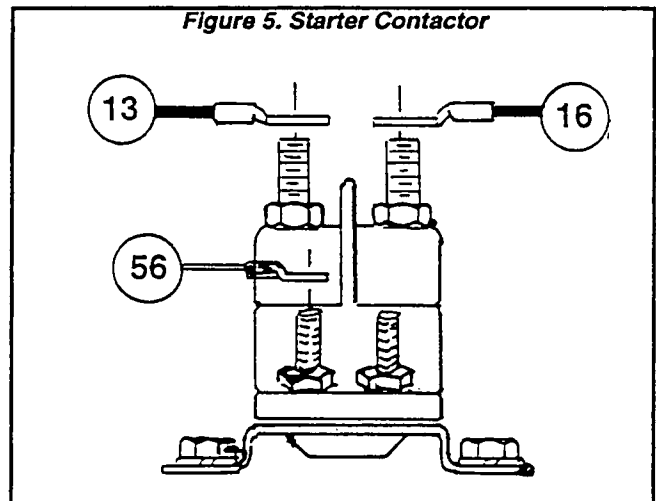

### Test 10- Check Engine Controller Board Power Supply

#### DISCUSSION:

Fused battery voltage is delivered to the Engine Controller circuit board via Wire 15. If this power (12 VDC) is not available to the board, cranking and startup will not be possible.

This test will determine if battery voltage is available to the circuit board for its operation.

#### TEST PROCEDURE:

Set a VOM to read battery voltage (12 VDC). Connect one VOM test lead to the Wire 15 terminal on the Engine Controller circuit board. Connect the other test lead to frame ground. The meter should indicate battery voltage.

#### RESULTS:

1. If battery voltage is NOT indicated, check Wire 15 between the 15 amp fuse and the Engine Controller board. Repair, reconnect or replace the wire as needed.
2. If 12 VDC was indicated, go to Test 12.

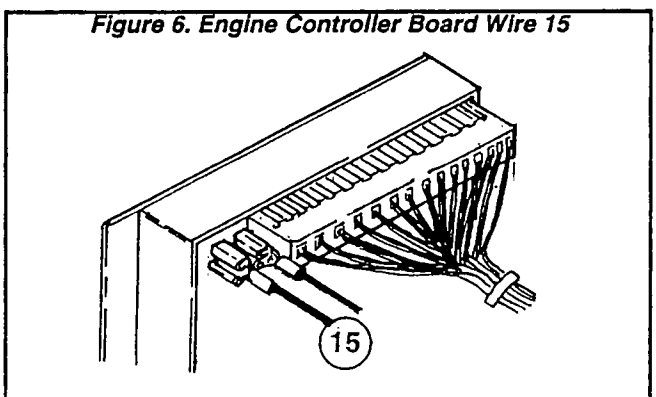

## Section 7.2- ENGINE DC CONTROL SYSTEM

### Test 11- Test Starter Contactor

#### DISCUSSION:

See "Starter Contactor" on Page 6.3-2. Replace Starter Contactor if bad.

### Test 12- Test Start-Stop Switch

#### DISCUSSION:

Engine cranking and startup are initiated when the Start-Stop switch is held at "START" to ground Wire 17.

Engine shutdown is normally initiated when the Start-Stop switch is set to "STOP" to ground Wire 18.

A defective switch can prevent normal startup or normal shutdown.

#### TEST PROCEDURE:

1. Carefully inspect Wire 0 (Ground) between the Start-Stop switch and the ground terminal. Repair, reconnect or replace the wire if necessary.
2. Disconnect Wire 17 from its terminal on the Start-Stop switch. Connect Wire 17 to a clean frame ground. The engine should crank.
3. Start the engine, using the Start-Stop switch or by grounding Wire 17.
4. Stop the engine by holding the Start-Stop switch at "STOP". If engine will not shut down with switch at "STOP", ground Wire 18 to stop engine.

#### RESULTS:

1. If engine cranks when Wire 17 is grounded, but won't crank with Start-Stop switch, replace the Start-Stop switch.
2. If engine stops when Wire 18 is grounded but will not shut down with Start-Stop switch, replace the Switch.
3. If engine will not crank when Wire 17 is grounded, replace the Engine Controller circuit board.
4. If engine will not stop when Wire 18 is grounded, replace the Engine Controller circuit board.

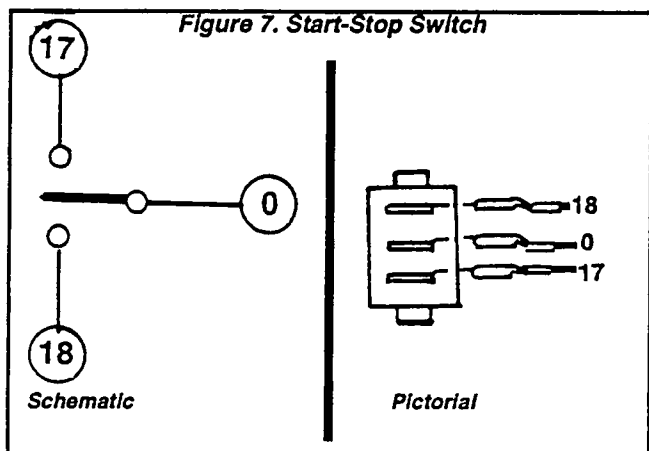

### Test 13- Check Fuel Supply

#### DISCUSSION:

If the engine cranks but won't start, don't overlook the obvious. The engine won't start without fuel.

#### TEST PROCEDURE:

Check fuel level.

#### RESULTS:

1. If fuel level is low, replenish fuel supply.
2. If fuel quantity is good, go to Test 14.

### Test 14- Check Fuel Filter

Refer to Section 3.3.

### Test 15- Check Ignition Spark

Refer to Section 6.4, "ENGINE IGNITION SYSTEM".

### Test 16- Check Spark Plug

#### DISCUSSION:

A badly fouled spark plug can prevent the engine from starting. A defective spark plug may allow the engine to be started, but rough operation or an "engine miss" may be observed.

A commercially available spark tester can be used to check for ignition spark. When the spark tester is connected in series with the spark plug and its high tension lead, the cause of an engine miss can be narrowed down to either (a) the ignition system, or (b) the spark plug or fuel system. Use of the spark tester is discussed in Test 16.

#### TEST PROCEDURE:

Remove the spark plug. Clean by scraping or wire brushing and by using a commercial solvent. **DO NOT BLAST CLEAN THE PLUG.** Set spark plug gap to 0.030 inch (0.76mm). Replace spark plug if badly fouled, if ceramic is cracked, or if damaged.

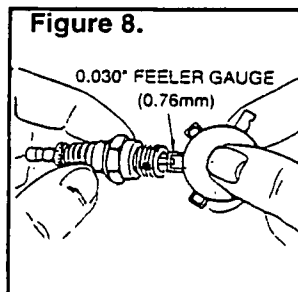

#### RESULTS:

1. Clean and regap or replace spark plug as necessary.
2. If spark plug is good but engine will not start, go to Test 3.
3. If spark plug is good but engine misses or runs rough, go to Test 23.

## Section 7.2- ENGINE DC CONTROL SYSTEM

### Test 17 – Check Ignition Power Supply

#### DISCUSSION:

During startup, the Engine Controller circuit board delivers DC power to the Ignition Module via Wire 14. If the engine cranks but won't start, one possible cause is loss of this power supply.

The DC power from the Engine Controller board is delivered to a 4-tab terminal connector. From that connector, it is routed to the Ignition Module. These components are all housed in the control panel.

#### TEST PROCEDURE:

In the control panel, inspect the Wire 14 connections at the 4-tab connector. Check Wire 14. Check the power supply as follows:

1. Set a VOM to read battery voltage.
2. Connect the VOM test leads across the 4-tab connector and frame ground.
3. Hold the engine Start-Stop switch at "START". The meter should read battery voltage.

#### RESULTS:

1. If DC voltage is NOT indicated, go to Test 21.
2. If DC voltage is good, go on to Test 18.

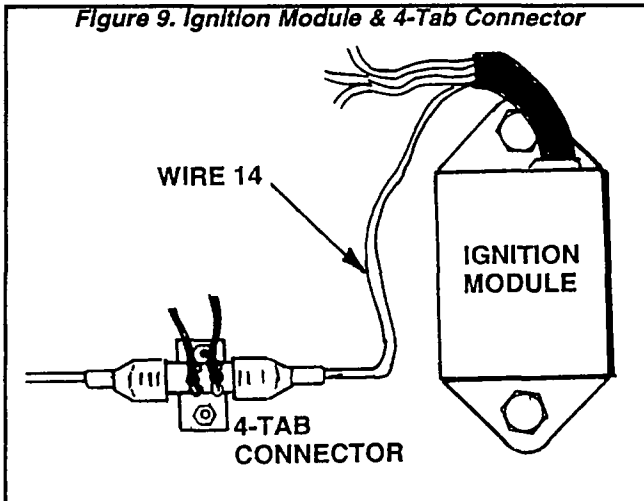

### Test 18- Check Ignition Sensor

#### DISCUSSION:

Refer to Section 6.4, "ENGINE IGNITION SYSTEM".

#### TEST PROCEDURE:

See Section 6.4.

#### RESULTS:

1. Replace Sensor, if bad.

2. If Sensor checks good, go to Test 19.

### Test 19- Check Ignition Coil

#### DISCUSSION:

See Section 6.4, "ENGINE IGNITION SYSTEM".

#### TEST PROCEDURE:

See Section 6.4.

#### RESULTS:

1. Replace Ignition Coil if bad.
2. If coil is good, go to Test 20.

### Test 20- Test Ignition Module

#### DISCUSSION:

See Section 6.4, "ENGINE IGNITION SYSTEM".

#### TEST PROCEDURE:

Refer to Section 6.4.

#### RESULTS:

Replace Ignition Module if bad.

### Test 21- Check Engine Controller Board Output to Wire 14

#### DISCUSSION:

If the engine cranks when the Start-Stop switch is set to "START", battery voltage must be available to the Engine Controller circuit board.

If the engine cranks but won't start, it is possible that a failure in the circuit board has occurred and DC power is not being delivered to the Wire 14 circuit.

This test will determine if circuit board action will deliver battery voltage to the necessary engine components.

#### PROCEDURE:

Set a VOM to read battery voltage. Connect the meter test leads across Terminal J2 of the Engine Controller board and Pin 12 of the circuit board connector (to which common ground Wire 0 connects). Crank the engine and the meter should read battery voltage.

#### RESULTS:

1. If DC voltage was NOT indicated in Test 17, but IS indicated now, repair, reconnect or replace Wire 14 between board and Ignition Module.
2. If no DC voltage in Test 3 but good voltage now, replace Wire 14 between board and fuel pump.



## Section 7.2- ENGINE DC CONTROL SYSTEM

3. If there is no DC output from the circuit board to Wire 14, replace the Engine Controller circuit board.

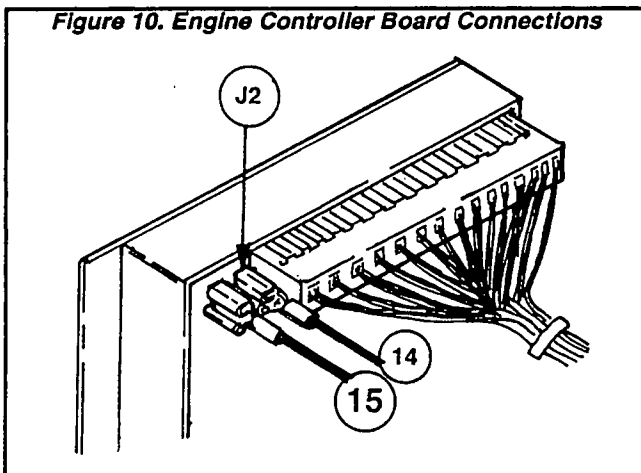

### Test 22-Test Automatic Choke

#### DISCUSSION:

Refer to Section 3.5, "AUTOMATIC CHOKE".

#### TEST PROCEDURE:

See Section 3.5.

#### RESULTS:

1. Adjust or repair choke system as necessary.
2. If choke is good, go to Test 23.

### Test 23- Check Carburetion

#### DISCUSSION:

If the engine won't start or if it starts hard and runs rough, one possible cause of the problem is carburetion.

#### PROCEDURE:

Before making a carburetion check, make sure the fuel tank has an ample supply of clean fresh gasoline (gasoline fuel systems) or gaseous fuel. The installer may have installed a gas or gasoline shutoff valve in the fuel supply system. Make sure all shutoff valves are open.

Adjust the carburetor as outlined on Page 3.4-2. Make sure the automatic choke is working properly and that the choke closes completely.

If the engine will not start, remove the spark plug and inspect it. If the plug is WET, look for the following:

- Overchoking.
- Water in fuel.

- Excessively rich fuel mixture.
- Intake valve stuck open.

- If the spark plug is DRY, look for the following:
- Carburetor gasket(s) leaking.
  - Fuel line plugged or shutoff valve not opening.
  - Intake valve stuck closed.
  - Inoperative fuel pump.
  - Clogged fuel filter.

#### RESULTS:

Adjust or repair carburetor or fuel system as necessary.

### Test 24- Check Engine

#### DISCUSSION:

An engine that will not start or one that starts hard and runs rough may be caused by a failure in the engine's mechanical system.

#### PROCEDURE:

The first step in checking for an engine problem is to perform a compression check. To check engine compression, proceed as follows:

1. Remove the spark plug.
2. Insert an automotive type compression gauge into the spark plug hole.
3. Crank the engine until there is no further increase in pressure. The highest reading obtained is the engine's compression pressure.

ENGINE COMPRESSION PRESSURE  
NOMINAL PRESSURE:- 60 psi  
MINIMUM ALLOWABLE:- 55 psi

**NOTE:** Full compression pressure cannot be obtained at cranking speeds, due to the action of a compression release mechanism.

#### RESULTS:

If compression is poor, look for one or more of the following possible causes:

1. Loose cylinder head bolts.
2. Failed cylinder head gasket.
3. Burned valves or valve seals.
4. Insufficient valve clearance.
5. Warped cylinder head.
6. Warped valve stem.
7. Worn or broken piston ring(s).
8. Worn or damaged cylinder bore.
9. Broken connecting rod.

## Section 7.2- ENGINE DC CONTROL SYSTEM

### **Test 25- Isolate the CCG System**

#### **DISCUSSION:**

If the engine starts, but then shuts down after startup, a problem could exist in either the generator computer system or in the engine DC control system. Refer to "CCG Circuit Board" on Pages 1.2-4 through 1.2-6.

This test will either eliminate the CCG system as a cause of the shutdown problem or it will prove that the problem is in the CCG system.

#### **TEST FIXTURE:**

The CCG circuit board must be able to detect certain electrical fault conditions and shut the engine down. See "AUTOMATIC SHUTDOWNS" on Page 1.2-5. For that purpose, Wire 18B is routed from the Engine Controller board to the CCG board. This wire has a negative DC voltage applied to it and shutdown will occur when CCG board action connects the wire to ground.

To isolate the CCG system as a cause of engine shutdown requires that Wire 18B be disconnected from the CCG circuit board. However, the CCG board "knows" when the wire is disconnected and will attempt to stop the engine if such disconnection occurs. Because the wire is disconnected, such a shutdown cannot occur. However, CCG board action will result in incorrect engine speeds if the wire is disconnected.

For the above reason, a test fixture is required to simulate the negative DC voltage normally supplied by Wire 18B. The test fixture consists of (a) a 9 volt battery, (b) a 1k resistor, and (c) necessary wiring and connectors. The negative side of the battery is connected to "CONN8" of the CCG circuit board. Connect the positive side of the battery to frame ground on the generator. See Figure 11.

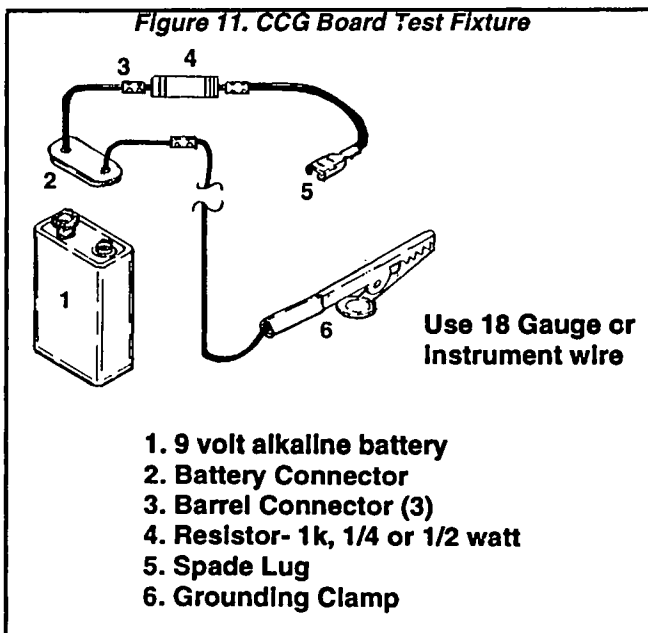

#### **PROCEDURE:**

Connect the test fixture to the circuit board's "CONN8" terminal and to the negative (-) terminal of a 12 volt battery. Connect the battery positive (+) terminal to frame ground. Crank and start the engine and observe its operation.

#### **RESULTS:**

1. If the engine starts and shuts down, check engine oil level.
  - a. If oil level is low, replenish as necessary.
  - b. If oil level is NOT low, go to Test 26.
2. If engine was shutting down after startup, but does not shut down during this test, the problem is in the CCG system. Go to Test 27.

### **Test 26- Test Oil Pressure Switch**

#### **DISCUSSION:**

See Section 6.5, "ENGINE PROTECTIVE DEVICES".

#### **TEST PROCEDURE:**

See Section 6.5.

If necessary, connect an external oil pressure gauge to the oil pressure switch port.

#### **RESULTS:**

1. Replace oil pressure switch if it is defective or repair Wire 85 circuit as necessary.
2. If oil pressure is actually low as indicated by the external gauge, see Section 5.1, "ENGINE OIL SYSTEM".
3. If oil pressure is good and oil pressure switch is good, go to Test 28.

### **Test 27- Test CCG System**

#### **DISCUSSION:**

If Test 25 indicated that engine shutdown or any other problem was being caused by the CCG system, this does not necessarily indicate a fault in the CCG system. The CCG board may be doing exactly what it was designed to do, i.e., initiate a shutdown when a fault exists in the generator system. The CCG board will shut the engine down on occurrence of one or more of the following faults:

1. Over-voltage.
2. Undervoltage (or overload).
3. Overspeed above 4500 rpm.
4. Zero current failure.
5. Converter failure.
6. Microprocessor failure.

**NOTE:** Also see "CCG Circuit Board" on Pages 1.2-4 through 1.2-6.

## **Section 7.2- ENGINE DC CONTROL SYSTEM**

---

### **TEST PROCEDURE:**

Refer to Section 7.1- "GENERATOR & SPEED CONTROL SYSTEM". That section consists of a "Troubleshooting Reference Chart" for the generator and CCG system.

For test procedures on the following components, refer to Section 1.5, "COMPONENTS TESTING".

If a problem is encountered on the speed control system, see Section 3.6, "GENERATOR & SPEED CONTROL SYSTEM".

**Section 7.2- ENGINE DC CONTROL SYSTEM**

---

**Part 8**  
**SPECIFICA-**  
**TIONS AND**  
**CHARTS**

**COMPUTER**  
**CONTROLLED**  
**VARIABLE**  
**SPEED RV**  
**GENERATORS**  
Series NP-30G and NP-40G

<b>PAGE</b>	<b>TITLE</b>
8-1	General Specifications
8-1	Nominal Resistances of Generator Windings
8-2	Electrical Schematic
8-3	Wiring Diagram
8-4 to 8-8	Engine Specifications
8-8	Engine Torque Specifications

# Part 8- SPECIFICATIONS & CHARTS

## Computer Controlled RV Generator Specifications

TYPE MODEL	NP-30G		NP-40G	
	9557	9847	9629	9848
TYPE OF ROTOR	Permanent Magnet Type			
RATED WATTS	3250	3250	3750	3750
RATED VOLTS	115	115	115	115
PHASE	1-Phase	1-Phase	1-Phase	1-Phase
RATED MAXIMUM LOAD AMPERES	28.3	28.3	31.3	31.3
RATED FREQUENCY	60 Hz	60 Hz	60 Hz	60 Hz
OPERATING SPEED (See NOTE 1)	Variable	Variable	Variable	Variable
ENGINE MODEL	See NOTE 2	See NOTE 2	GN-220	GN-220
TYPE OF ENGINE	Vertical Shaft	Vertical Shaft	Vertical Shaft	Vertical Shaft
FUEL SYSTEM	Gasoline	LP gas	Gasoline	LP Gas
COOLING SYSTEM	Air-Cooled	Air-Cooled	Air-Cooled	Air-Cooled
OIL SYSTEM	Pressure	Pressure	Pressure	Pressure
OIL PUMP	Trochoid Type	Trochoid Type	Trochoid Type	Trochoid Type
AIR CLEANER	Paper element w/ foam pre-cleaner	Paper element w/foam pre-cleaner	Paper element w/foam pre-cleaner	Paper element w/foam pre-cleaner
STARTER	12 VDC electric	12 VDC electric	12 VDC electric	12 VDC electric
IGNITION SYSTEM	Solid State	Solid State	Solid State	Solid State
SPARK PLUG	Champlon RC12YC (or equivalent)	Champlon RC12YC (or equivalent)	Champlon RC12YC (or equivalent)	Champlon RC12YC (or equivalent)
SPARK PLUG GAP	0.030 inch (0.76mm)	0.030 inch (0.76mm)	0.030 inch (0.76mm)	0.030 inch (0.76mm)

NOTE 1: Engine speed will vary between approximately 2300-3910 rpm, depending on the load and load voltage.

NOTE 2: Models 9557-0 AND 9557-1 employed the Model GN-190 engine. Models 9557-2 and later revisions use the GN-220 engine.

### Nominal Resistances of Generator Windings

#### Stator Power Phase Windings

Lead AC1 to 11..... 0.30 to 0.42 ohm  
 Lead AC2 to 11.....0.30 to 0.42 ohm  
 Lead SL1 to 11 .....0.30 to 0.42 ohm  
 Lead SL2 to 11 .....0.30 to 0.42 ohm

#### Stator Timing Winding

Lead TIM 1 (orange)  
 to TIM 2 (gray) - (Pin 2  
 to Pin 4 of CONN4 con-  
 nector plug).....0.35 to 0.44 ohm

#### Stator Power Supply Winding

Lead PS1 to PS3 .....0.35 to 0.44 ohm  
 (Pin 1 to Pin 3 of CONN4 connector plug)

#### Stator Battery Charge Windings

Lead 55 to 77 .....0.037-0.042 ohm  
 Lead 55 to 66 .....0.037-0.042 ohm

# Part 8- SPECIFICATIONS & CHARTS

## Electrical Schematic (Drawing No. 88928)

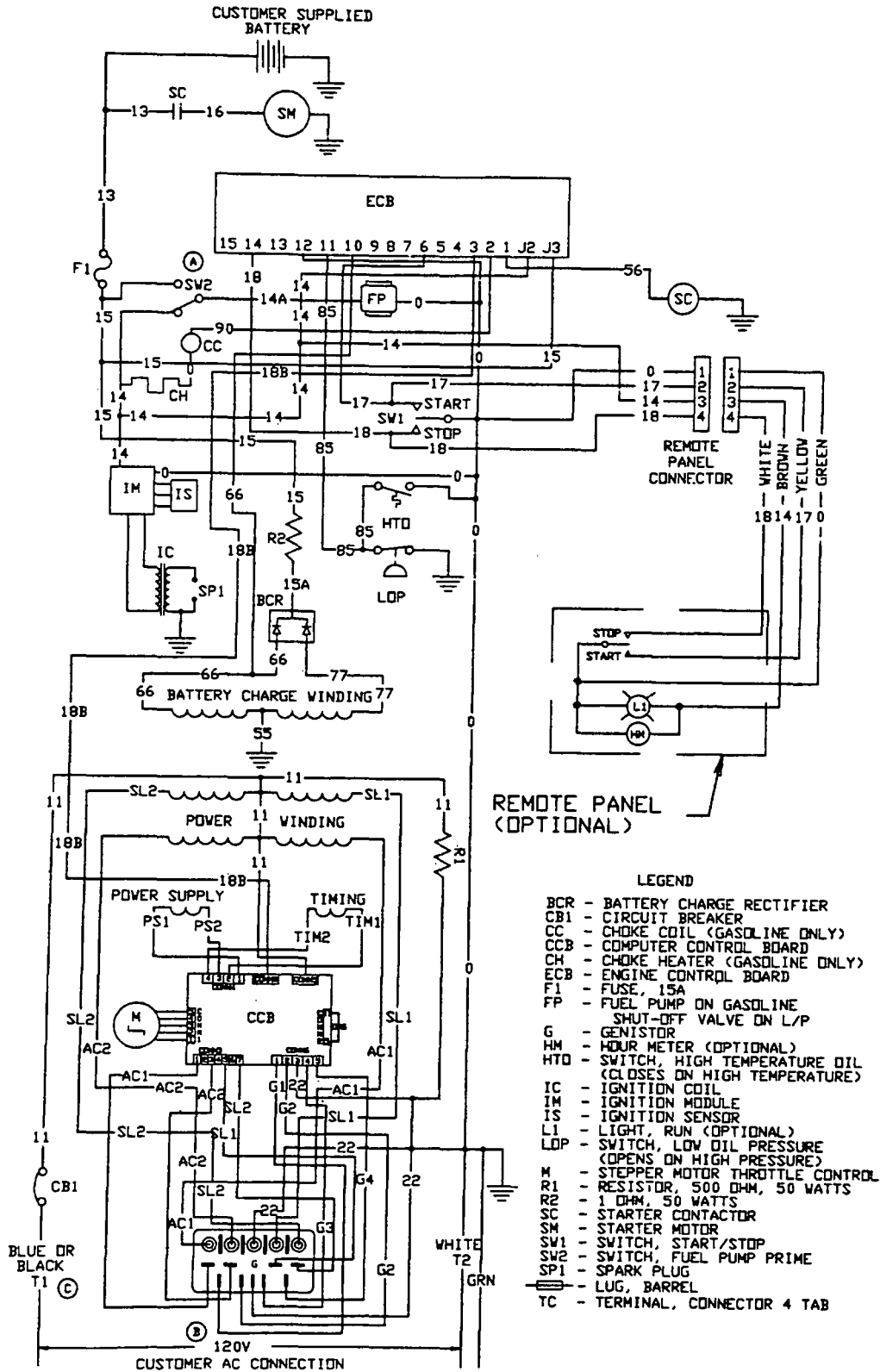

# Part 8- SPECIFICATIONS & CHARTS

## Wiring Diagram (Drawing No. 88928)

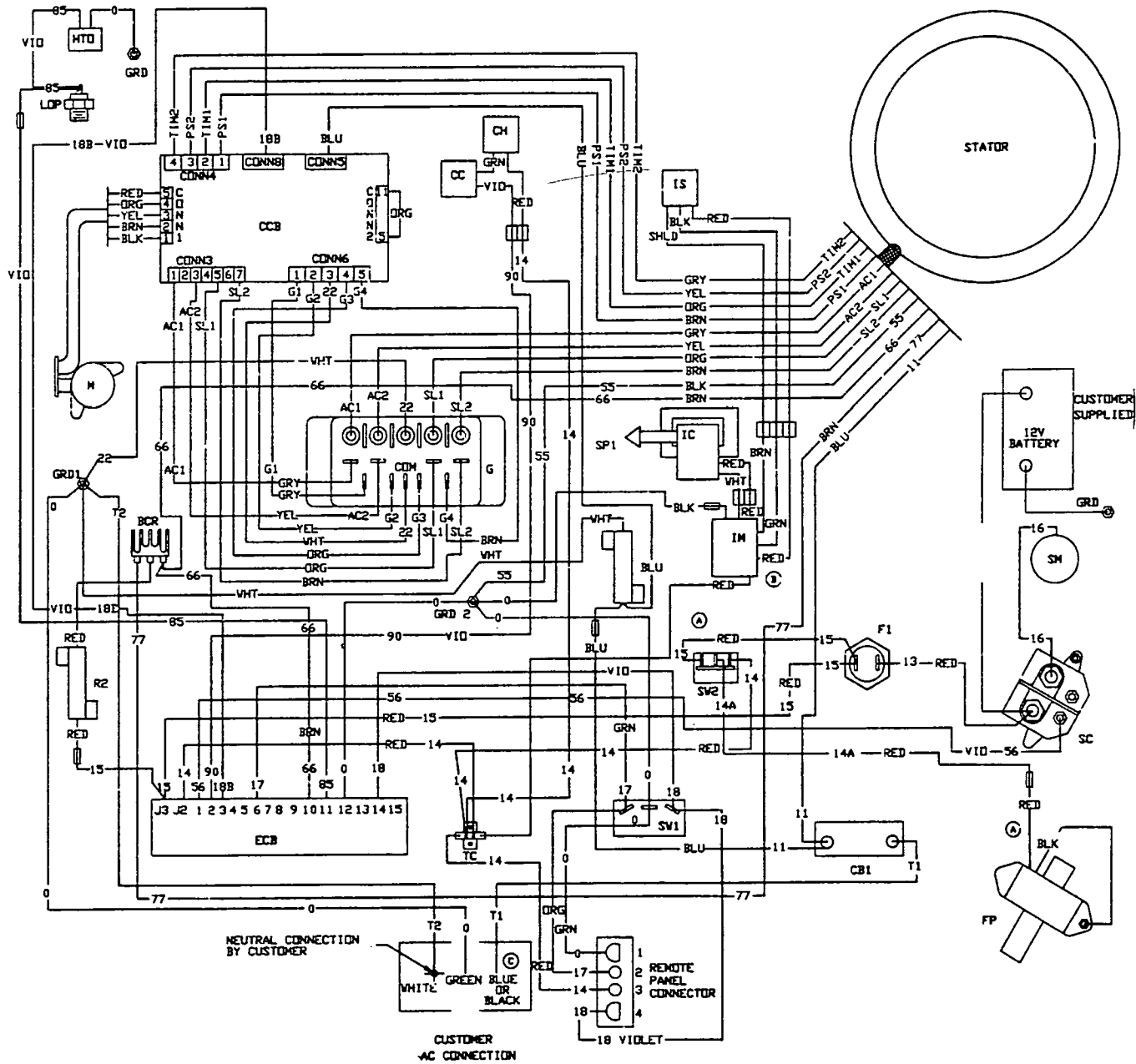



# PART 8- SPECIFICATIONS & CHARTS

## Engine Specifications

### GENERAL:

MODEL NUMBER	GN-190	GN-220
BORE	2.76 inches (70mm)	2.95 inches (75mm)
STROKE	1.93 inches (49mm)	1.93 inches (49mm)
DISPLACEMENT	190cc	216.5cc

### VALVE TRAIN:

<b>VALVE SEAT WIDTH AND ANGLE:</b> Design Width Wear Limit Grind Seats to Valve Seat Angle	0.034-0.044 inch (0.87-1.13mm) 0.064 inch (1.63mm) maximum  0.040 inch (1.00mm) width	0.034-0.044 inch (0.87-1.13mm) 0.064 inch (1.63mm) maximum  0.040 inch (1.00mm) width
<b>VALVE MARGIN:</b> Design Margin Wear Limit	0.058-0.060 inch (1.48-1.52mm) 0.039 (0.98mm) inch maximum	0.034-0.044 inch (0.87-1.13mm) 0.020 inch (0.50mm) maximum
<b>INTAKE VALVE STEM DIAMETER:</b> Design Diameter Wear Limit	0.215-0.216 inch (5.465-5.480mm) 0.214 inch (5.435mm) Minimum	0.274-0.275 inch (6.965-6.980mm) 0.273 inch (6.934mm) Minimum
<b>EXHAUST VALVE STEM DIAMETER:</b> Design Diameter Wear Limit	0.214-0.215 inch (5.445-5.460mm) 0.213 inch (5.415mm) Minimum	0.273-0.274 inches (6.945-6.960mm) 0.272 inch (6.909mm) Minimum
<b>TAPPET DIAMETER (INTAKE &amp; EXHAUST):</b> Design Diameter Wear Limit	0.294-0.295 inch (7.461-7.475mm) 0.293 inch (7.431mm) Minimum	0.293-0.294 inch (7.457-7.475mm) 0.292 inch (7.417mm) Minimum
<b>VALVE SPRINGS:</b> Free Length Force needed to compress spring to 1.39 inch (35.2mm)	1.910 inch (48.48mm) 14.8-16.3 lbs (6.7-7.4kg)	2.074 inch (52.69mm) 21.8-19.8 lbs (9.9-9.0 kg)
<b>VALVE CLEARANCE:</b> Intake Exhaust	0.001-0.003 inch (0.03-0.07mm) 0.001-0.003 inch (0.03-0.07mm)	0.001-0.0022 inch (0.03-0.056mm) 0.0018-0.003 inch (0.046-0.07mm)
<b>VALVE GUIDES:</b> Design Diameter Wear Limit	0.216-0.217 inch (5.505-5.520mm) 0.218 inch (5.54mm) maximum	0.237-0.2364 inch (6.02-6.005mm) 0.238 inch (6.045mm) maximum

### CRANKCASE ASSEMBLY:

<b>CYLINDER BORE:</b> Design Diameter Wear Limit	2.756-2.757 inch (70.000-70.025mm) 2.760 inch (70.105mm)	2.953-2.954 inch (75.000-75.025mm) 2.957 inch (75.108mm)
<b>VALVE TAPPET BORE:</b> Design Diameter Wear Limit	0.295-0.296 inch (7.494-7.520mm) 0.297 inch (7.55mm)	0.295-0.296 inch (7.494-7.520mm) 0.297 inch (7.55mm)

# Part 8- SPECIFICATIONS & CHARTS

## Engine Specifications (Continued)

MODEL NO.	GN-190	GN-220
-----------	--------	--------

### CRANKCASE ASSEMBLY (CONTINUED):

<b>CRANKSHAFT SLEEVE BEARING:</b> Design Diameter Wear Limit	1.104-1.106 Inch (28.044-28.099mm) 1.107 Inch (28.129mm) Maximum	1.104-1.106 Inch (28.044-28.099mm) 1.107 Inch (28.129mm) Maximum
<b>GOVERNOR ARM BORE:</b> Design Diameter Wear Limit	0.239-0.240 Inch (6.07-6.10mm) 0.242 Inch (6.15mm) Maximum	0.239-0.240 Inch (6.107-6.10mm) 0.242 Inch (6.15mm ) Maximum
<b>CAMSHAFT BEARING:</b> Design Diameter Wear Limit	1.024-1.025 Inch (26.00-26.03mm) 1.026 Inch (26.06mm) Maximum	1.024-1.025 Inch (26.00-26.03mm) 1.026 Inch (26.06mm) Maximum
<b>GOVERNOR ARM DIAMETER:</b> Design Diameter Wear Limit	0.235-0.237 Inch (6.07-6.10mm) 0.233 Inch (5.92mm)	0.235-0.237 Inch (5.97-6.03mm) 0.233 Inch (5.92mm)

### CRANKCASE COVER ASSEMBLY:

<b>CRANKSHAFT BEARING BORE DIAMETER:</b> Design Diameter Wear Limit	1.103-1.105 Inch (28.030-28.058mm) 1.106 Inch (28.088mm) Maximum	1.104-1.105 Inch (28.040-28.065mm) 1.106 Inch (28.092mm) Maximum
<b>CAMSHAFT BEARING BORE DIAMETER:</b> Design Diameter Wear Limit	1.299-1.300 Inch (33.00-33.03mm) 1.302 Inch (33.06mm) Maximum	1.299-1.300 Inch (33.00-33.03mm) 1.302 Inch (33.06mm) Maximum
<b>GOVERNOR GEAR SHAFT DIAMETER:</b> Design Diameter	0.236-0.237 Inch (6.004-6.012mm)	0.236-0.237 Inch (6.004-6.012mm)
<b>OIL PUMP INNER ROTOR SHAFT DIAMETER:</b> Design Diameter Wear Limit	0.353-0.354 Inch (8.969-8.987mm) 0.352 Inch (8.949mm) Minimum	0.353-0.354 Inch (8.969-8.987mm) 0.352 Inch (8.949mm) Minimum

### CRANKSHAFT:

<b>CRANKPIN DIAMETER:</b> Design Diameter Wear Limit	1.180-1.181 Inch (29.99-30.01mm) 1.179 Inch (29.96mm) Minimum	1.180-1.181 Inch (29.99-30.01mm) 1.179 Inch (29.96mm) Minimum
<b>CRANKSHAFT MAIN BEARING (FLYWHEEL END)</b> Design Diameter Wear Limit	1.102-1.103 Inch (28.000-28.012mm) 1.100 Inch (27.95mm) Minimum	1.102-1.103 Inch (28.000-28.012mm) 1.100 Inch (27.95mm) Minimum
<b>CRANKSHAFT MAIN BEARING (PTO END)</b> Design Diameter Wear Limit	1.102-1.103 Inch (28.000-28.012mm) 1.186 Inch (27.95mm) Minimum	1.102-1.103 Inch (28.000-28.012mm) 1.186 Inch (27.95mm) Minimum

### CONNECTING ROD ASSEMBLY:

<b>LARGE END INSIDE DIAMETER:</b> Design Diameter Wear Limit	1.183-1.184 Inch (30.06-30.07mm) 1.186 Inch (30.12mm) Maximum	1.183-1.184 Inch (30.06-30.07mm) 1.186 Inch (30.12mm) Maximum
--	--	--

# Part 8- SPECIFICATIONS & CHARTS

## Engine Specifications (Continued)

MODEL NO.	GN-190	GN-220
-----------	--------	--------

### CONNECTING ROD ASSEMBLY (CONT'D):

<b>SMALL END INSIDE DIAMETER:</b> Design Diameter Wear Limit	0.709-0.710 Inch (18.02-18.03mm) 0.711 Inch (18.05mm) Maximum	0.709-0.710 Inch (18.02-18.03mm) 0.711 Inch (18.05mm) Maximum
<b>PISTON PIN OUTSIDE DIAMETER:</b> Design Diameter Wear Limit	0.708-0.709 Inch (17.989-18.000mm) 0.707 Inch (17.969mm) Minimum	0.708-0.709 Inch (17.989-18.000mm) 0.707 Inch (17.969mm) Minimum
<b>PISTON PIN LENGTH:</b> Design Length Wear Limit	2.196-2.213 Inch (55.8-56.2mm) 2.193 Inch (55.7mm) Minimum	2.196-2.213 Inch (55.8-56.2mm) 2.193 Inch (55.7mm) Minimum

### PISTON:

<b>PISTON MAJOR DIAMETER:</b> Design Diameter Wear Limit	2.753-2.754 Inch (69.939-69.959mm) 2.751 Inch (69.89mm) Minimum	2.753-2.754 Inch (69.939-69.959mm) 2.751 Inch (69.89mm) Minimum
<b>PISTON MINOR DIAMETER:</b> Design Diameter Wear Limit	2.747-2.748 Inch (69.789-69.809mm) 2.745 Inch (69.739mm) Minimum	2.747-2.748 Inch (69.789-69.809mm) 2.745 Inch (69.739mm) Minimum
<b>WRIST PIN BORE DIAMETER:</b> Design Diameter Wear Limit	0.708-0.709 Inch (18.000-18.011mm) 0.710 Inch (18.026mm) Maximum	0.708-0.709 Inch (18.000-18.011mm) 0.710 Inch (18.026mm) Maximum
<b>TOP RING GROOVE WIDTH:</b> Design Width Wear Limit	0.059-0.061 Inch (1.52-1.54mm) 0.062 Inch (1.57mm) Maximum	0.059-0.061 Inch (1.52-1.54mm) 0.062 Inch (1.57mm) Maximum
<b>SECOND RING GROOVE WIDTH:</b> Design Width Wear Limit	0.059-0.061 Inch (1.52-1.54mm) 0.062 Inch (1.57mm) Maximum	0.059-0.061 Inch (1.52-1.54mm) 0.062 Inch (1.57mm) Maximum
<b>OIL CONTROL RING GROOVE WIDTH:</b> Design Width Wear Limit	0.118-0.119 Inch (3.01-3.03mm) 0.120 Inch (3.06mm) Maximum	0.118-0.119 Inch (3.01-3.03mm)
<b>TOP RING WIDTH:</b> Design Width Wear Limit	0.057-0.059 Inch (1.47-1.49mm) 0.056 Inch (1.44mm) Minimum	0.057-0.059 Inch (1.47-1.49mm) 0.056 Inch (1.44mm) Minimum
<b>TOP RING END GAP*:</b> Design End Gap Wear Limit	0.005-0.016 Inch (0.15-0.40mm) 0.024 Inch (0.60mm) Maximum	0.005-0.016 Inch (0.15-0.40mm) 0.024 Inch (0.60mm) Maximum
<b>SECOND RING WIDTH:</b> Design Width Wear Limit	0.057-0.059 Inch (1.465-1.490mm) 0.056 Inch (1.435mm) Minimum	0.057-0.059 Inch (1.465-1.490mm) 0.056 Inch (1.435mm) Minimum
<b>SECOND RING END GAP*:</b> Design End Gap Wear Limit	0.005-0.016 Inch (0.15-0.40mm) 0.024 Inch (0.60mm) Maximum	0.006-0.016 Inch (0.15-0.40mm) 0.024 Inch (0.60mm) Maximum

\* Measure ring end gap with ring pushed down into cylinder to depth of 2.75 Inches (69.85mm).

# Part 8- SPECIFICATIONS & CHARTS

## Engine Specifications (Continued)

MODEL NO.	GN-190	GN-220
-----------	--------	--------

### PISTON (CONT'D):

<b>OIL CONTROL RING WIDTH:</b> Assembled Width Wear Limit	0.111-0.118 Inch (2.825-3.003mm) 0.110 Inch (2.795mm)	0.111-0.118 Inch (2.825-3.003mm) 0.110 Inch (2.795mm)
<b>OIL CONTROL RING END GAP*:</b> Design End Gap Wear Limit	0.015-0.055 Inch (0.38-1.40mm) 0.062 Inch (1.60mm) Maximum	0.015-0.055 Inch (0.38-1.40mm) 0.062 Inch (1.60mm) Maximum

### CAMSHAFT ASSEMBLY:

<b>MAIN CAMSHAFT BEARING DIAMETER (FLYWHEEL END):</b> Design Diameter Wear Limit	1.022-1.023 Inch (25.96-25.98mm) 1.020 Inch (25.91mm) Minimum	1.022-1.023 Inch (25.96-25.98mm) 1.020 Inch (25.91mm) Minimum
<b>MAIN CAMSHAFT BEARING DIAMETER (PTO END):</b> Design Diameter Wear Limit	1.022-1.023 Inch (25.96-25.98mm) 1.020 Inch (25.91mm) Minimum	1.297-1.298 Inch (32.96-32.98mm) 1.295 Inch (32.89mm) Minimum
<b>CAM LIFT:</b> Design Lift Wear Limit	0.210-0.212 Inch (5.34-5.38mm) 0.206 Inch (5.24mm) Minimum	0.210-0.212 Inch (5.34-5.38mm) 0.206 Inch (5.24mm) Minimum
<b>BASE CIRCLE DIAMETER OF CAM:</b> Design Diameter Wear Limit	0.978-0.990 Inch (24.85-25.15mm) 0.974 Inch (24.75mm) Minimum	0.978-0.990 Inch (24.85-25.15mm) 0.974 Inch (24.75mm) Minimum
<b>COMPRESSION RELEASE LIFT (MEASURED AT TAPPET):</b> Design Lift Wear Limit	0.027-0.055 Inch (0.70-1.40mm) 0.023 Inch (0.60mm) Minimum	0.020-0.047 Inch (0.50-1.2mm) 0.016 Inch (0.406mm) Minimum

### OIL PUMP:

<b>PUMP TIP CLEARANCE (Measure on shaft in sump cover):</b> Design Clearance Wear Limit	0.0000-0.0010 Inch (0.000-0.025mm) 0.004 Inch (0.105mm) Maximum	0.0000-0.0010 Inch (0.000-0.025mm) 0.004 Inch (0.105mm) Maximum
<b>INNER PUMP ROTOR BORE:</b> Design Bore Wear Limit	0.354-0.355 Inch (9.000-9.019mm) 0.357 Inch (9.034mm) Maximum	0.354-0.355 Inch (9.000-9.019mm) 0.357 Inch (9.034mm) Maximum
<b>INNER ROTOR THICKNESS:</b> Design Thickness Wear Limit	0.312-0.315 Inch (7.95-8.00mm) 0.311 Inch (7.90mm) Minimum	0.312-0.315 Inch (7.95-8.00mm) 0.311 Inch (7.90mm) Minimum

# Part 8- SPECIFICATIONS & CHARTS

## Engine Specifications (Continued)

MODEL NO.	GN-190	GN-220
-----------	--------	--------

### OIL PUMP (CONT'D):

OUTER PUMP ROTOR OUTSIDE DIAMETER: Design Diameter Wear Limit	1.296-1.297 Inch (32.92-32.95mm) 1.292 Inch (32.82mm) Minimum	1.296-1.297 Inch (32.92-32.95mm) 1.292 Inch (32.82mm) Minimum
OUTER PUMP ROTOR THICKNESS: Design Thickness Wear Limit	0.314-0.316 Inch (8.000-8.025mm) 0.312 Inch (7.95mm) Minimum	0.314-0.316 Inch (8.000-8.025mm) 0.312 Inch (7.95mm) Minimum
OIL PRESSURE RELIEF VALVE SPRING: Force required to compress spring to 1.035 Inch (26.3mm)	0.85-0.95 lbs (0.39-0.43 kg)	0.85-0.95 lbs (0.39-0.43 kg)

### CRANKSHAFT END PLAY:

Allowable crankshaft end play	0.006-0.023 Inch (0.14-0.60mm)	0.006-0.023 Inch (0.14-0.60mm)
-------------------------------	--------------------------------	--------------------------------

### COMPRESSION PRESSURE:

While Cranking (Cold Engine)	60 psi Minimum	60 psi Minimum
------------------------------	----------------	----------------

## Engine Torque Specifications

Cylinder Head Bolts	25 lb-ft	29 lb-ft
Connecting Rod Bolts	10 lb-ft	10 lb-ft
Flywheel Nut	75 lb-ft	75 lb-ft
Sump Cover Bolts	100 lb-in	18 lb-ft
Ignition Coil Mount Bolts	5 lb-ft	5 lb-ft
Spark Plug	13 lb-ft	13 lb-ft
Intake Elbow	5 lb-ft	5 lb-ft
Carburetor to Intake Elbow	3.8 lb-ft	3.8 lb-ft
Rocker Arm Pivot Ball Jam Nut	6.3 lb-ft	6.3 lb-ft

## ENGINE SPEEDS, AND VOLTAGE SPECIFICATIONS

Listed below are normal running voltages, load voltages, and engine speeds. Frequency should stay between 57HZ to 63HZ, changing depending on load change.

### NP30G

APPLIED LOAD AMPS	VOLTAGES	ENGINE SPEEDS (rpm)
0	113-121	2400-2800
10	113-121	2700-3300
25	115-124	3300-4000

### NP30G/LP

APPLIED LOAD AMPS	VOLTAGES	ENGINE SPEEDS (rpm)
0	116-122	2250-2800
10	118-122	2800-3300
25	115-124	3500-3910

### NP40G

APPLIED LOAD AMPS	VOLTAGES	ENGINE SPEEDS (rpm)
0	113-121	2400-2800
10	113-121	2750-3300
20	117-121	3150-3750
30	109-124	3500-4000

### NP40G/LP

APPLIED LOAD AMPS	VOLTAGES	ENGINE SPEEDS (rpm)
0	115-122	2200-2600
10	116-122	2600-3100
20	118-122	3050-3600
30	106-124	3250-3910

**\*\*NOTE\*\*** For information use only. Units have been preset at the factory to match these specifications.