

OWNER'S MANUAL

and Installation Instructions

IMPACT-36 plus with Inverter

AIR-COOLED RECREATIONAL VEHICLE GENERATORS

Model Nos. 00940-1, 00941-1

GENERAC[®]
POWER SYSTEMS, INC.

GENERAL SAFETY RULES





THE MANUFACTURER SUGGESTS THAT THESE "RULES" FOR SAFE OPERATION BE COPIED AND POSTED IN POTENTIAL HAZARD AREAS OF THE RECREATIONAL VEHICLE. SAFETY SHOULD BE STRESSED TO ALL OPERATORS AND POTENTIAL OPERATORS OF THIS EQUIPMENT.



Study these SAFETY RULES carefully before operating or servicing applicable equipment. Become familiar with this Owner's Manual and with your generator. Safe, efficient and reliable operation can only be achieved if generator is properly installed, operated and maintained. Many accidents are caused by failing to follow simple and fundamental rules or precautions. The manufacturer suggests that these GENERAL SAFETY RULES be copied and posted in potential hazard areas of the recreational vehicle. Safety should be stressed to all operators and potential operators of equipment.

The manufacturer cannot possibly anticipate every circumstance that might involve a hazard. The warnings in this manual and on tags and decals affixed to the unit are, therefore, not all-inclusive. If you use a procedure, work method or operating technique Generac does not specifically recommend, you must satisfy yourself that it is safe for you and others. You must also make sure the procedure, work method or operating technique that you chose does not render the generator to be unsafe.

 WARNING: 
The engine exhaust from this product contains chemicals known to the State of California to cause cancer, birth defects, or other reproductive harm.

 For fire safety, the recreational vehicle generator must be properly installed and maintained. Installation must always remain in compliance with applicable codes and standards. In addition, the generator must be installed in conformance to the manufacturer's detailed installation instructions. Following installation, nothing must be done that might render the generator in noncompliance with such codes, standards and instructions.

 The RV generator produces extremely high and dangerous electrical voltages and can cause dangerous, and possibly fatal, electrical shock. Avoid contact with bare wires, terminals, etc. while the unit is running. If you must work around an operating generator, stand on an insulated, dry surface to reduce shock hazard.

- Never work on this equipment or handle any electrical device while standing in water, while barefoot, or while hands or feet are wet. Dangerous electrical shock will result.
- Have the generator properly grounded (bonded) during installation onto the vehicle, either by solid mounting to the vehicle frame or chassis or by means of an approved bonding conductor. DO NOT disconnect the bonding conductor, if so equipped. DO NOT reconnect the bonding conductor to any generator part that might be removed or disassembled during routine maintenance. If the grounding conductor must be replaced, use only a flexible conductor that is of No. 8 AWG copper wire minimum.

- In case of accident caused by electric shock, shut down the source of electrical power down at once. If this cannot be done, free victim from live conductor. AVOID DIRECT CONTACT WITH THE VICTIM. Use a dry board, dry rope, or other non-conducting implement to free the victim from live conductor. Apply first aid and get medical help.

 Inspect fuel system frequently for leaks or damage. Repair or replace any damaged or leaking component immediately. Never attempt to change, alter or modify the generator fuel system in any way that might affect safety or compliance with applicable codes and standards.

- The generator engine gives off DEADLY carbon monoxide gas through its exhaust system. This dangerous gas, if breathed in sufficient concentrations, can cause unconsciousness or even death. This exhaust system must have been properly installed, in strict compliance with applicable codes and standards. Following installation, you must do nothing that might render the system unsafe or in non-compliance with such codes and standards. The generator compartment must be completely vapor sealed from vehicle interior. There must be no possibility of exhaust fumes entering the vehicle interior. Never operate this equipment with a leaking or defective exhaust system.

- Never use the generator or any of its parts as a step. Stepping on the unit can stress and break parts and may result in dangerous, fuel leakage, oil leakage, etc.

 Do not smoke around the generator. Wipe up any fuel and oil spills immediately. Never leave oily or fuel soaked rags in the generator compartment or on the generator itself. Keep the area around the generator clean and free of debris.

 Adequate ventilation is required to expel toxic fumes and fuel vapors from the generator compartment. Do not alter the installation of this equipment in any manner that might obstruct air and ventilation openings. Such openings must be kept clear and unobstructed.

- Keep hands, feet, clothing, etc., away from drive belts, fans and other moving parts of this equipment. Never remove any drive belt or fan guards while the unit is operating.
- Inspect the generator periodically. Repair or replace all damaged or defective parts immediately.

 These generators can be converted to use LP gas (propane) as a fuel. Liquid Propane gas is highly EXPLOSIVE. The gas is heavier than air and tends to settle in low areas where even the slightest spark can ignite the gas and cause an explosion.

 Before performing any maintenance on the generator set, disconnect its battery cables to prevent accidental start up. Disconnect the cable from the battery post indicated by a NEGATIVE, NEG or (-) first. Reconnect that cable last.

TABLE OF CONTENTS

OPERATING INSTRUCTIONS		Equipment Description	16
GENERAL SAFETY RULES	inside cover	Engine Generator Operating Speed	16
IDENTIFICATION RECORD	2-3	LOCATION AND SUPPORT	
GENERATOR and INVERTER FEATURES	2-4	Generator Location	17
READ THIS MANUAL THOROUGHLY		Generator Support	17
Operation and Maintenance	5	Suspended Mounting	17
How to Obtain Service	5	Generator Restraint	18
Service Dealer Location	5	GENERATOR COMPARTMENTS	
GENERATOR FAMILIARIZATION		Compartment Seams	18
Generator Applicability	6	Compartment Size	19
Safety	6	Compartment Construction	19
OPERATING INSTRUCTIONS		Sound Insulation Materials	19
Generator Control Panel	7	Compartment Floor Cutouts	20
Automatic Choke (Gasoline only)	7	Acoustics	20
Before Starting the Engine	7-8	COOLING AND VENTILATION AIR	
Starting	8	Generator Air Flow	21
Stopping the Generator	8	Cooling Air Inlet Openings	21-22
Applying Loads to Generator	8	Compensating for Restrictions	22
Attention Required After Submersion	8	Inverter Location	22
Operation in High Grass or Brush	8	Testing the Installation	22
Operating Precautions	8-9	GASOLINE FUEL SYSTEM	
Effects of Moisture and Dirt	9	Fuel Tank	23
Do Not Overload the Generator	9	Generator Fuel Supply Line	23-24
ENGINE PROTECTIVE DEVICES		PROPANE GAS FUEL SYSTEM	
Automatic Low Oil Pressure Shutdown	9	Parts Not Included in Fuel System	24
High Temperature Shutdown	9	Some Important Considerations	24
Overspeed	9	Vapor Withdrawal	24
Low Voltage	9	Primary Regulator	24-25
SPECIFICATIONS		Gaseous Carburetion	25
Fuel Requirements	10	Fuel Supply Lines	25
Engine Oil Requirements	10	Excess Flow Valve	25
Generator Specifications	10	Leakage Tests	25
Engine Specifications	10	EXHAUST SYSTEM	
MAINTENANCE		Mufflers and Spark Arrestors	26
Checking Engine Oil Level	11	Type of Exhaust System	26
Change Engine Oil	11	Exhaust System Safety	26
Change Oil Filter	11	ELECTRICAL CONNECTIONS	
Engine Air Cleaner	11-12	Wiring	27
Clean Air Intake Screen	12	Generator AC Connection System	27
Engine Spark Plug	12	Isolating Different Power Sources	27
Fuel Filter	12	Power Supply Cord	27
Inverter	12	Ground Fault Circuit Interrupters	28
Cleaning the Generator	12	Sensing Harnesses	28
Battery	13	Transfer Switch Isolation Method	29
Service and Adjustments	13	Installation with Isolation Receptacle	29
Adjusting the Carburetor	13	BATTERY INSTALLATION	30
Adjusting Valve Clearance	13	OPTIONAL ACCESSORIES	31
Major Service Manual	14	POST INSTALLATION TESTS	32
Exercising the Generator	14	INSTALLATION CHECK LIST	33
Out of Service Protection	14	MAJOR FEATURES AND DIMENSIONS	34-35
Return the Unit to Service after Storage	14	TROUBLESHOOTING	36
Service Dealer Location	14	NOTES	37
INSTALLATION SAFETY RULES	15	ELECTRICAL DATA	38-39
Notice to Installer	15	REPAIR PARTS	40 to 51
Safety Rules	15	EMISSIONS WARRANTY	52 - 53
GENERAL INSTALLATION INFORMATION		WARRANTY	back page
Purpose and Scope of Manual	16		
Safety	16		
Standards Booklets	16		

IDENTIFICATION RECORD

Please record the following information from the generator DATA DECAL or information decal.

- | | |
|-----------------------|------------------------|
| 1. Model Number _____ | 2. Serial Number _____ |
| 3. kW Rating _____ | 4. Rated Voltage _____ |
| 5. Phase _____ | 6. Hertz _____ |

IMPACT-36G plus FEATURES

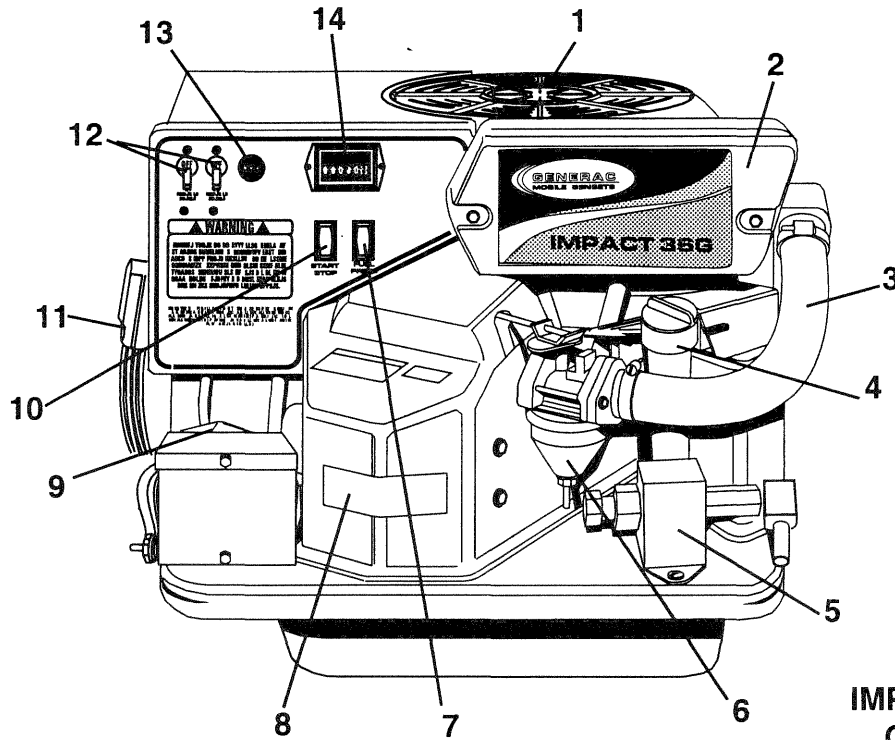

**IMPACT-36 plus
GASOLINE**

REFERENCE NUMBER IDENTIFICATION

- | | |
|---------------------------------|-------------------------------|
| 1. Generator Air Intake Screen | 8. Data Decal |
| 2. Air Cleaner | 9. 12 Volt Battery Connection |
| 3. Air Intake Tube | 10. Engine Start/Stop Switch |
| 4. Oil Dipstick and Filler Tube | 11. Generator DC Output Leads |
| 5. Fuel Pump | 12. Circuit Breaker |
| 6. Gasoline Carburetor | 13. Fuse |
| 7. Fuel Primer Switch | 14. Hour Meter |

IDENTIFICATION RECORD

Please record the following information from the generator DATA DECAL or information decal.

1. Model Number _____

2. Serial Number _____

3. kW Rating _____

4. Rated Voltage _____

5. Phase _____

6. Hertz _____

IMPACT-36LPG plus FEATURES

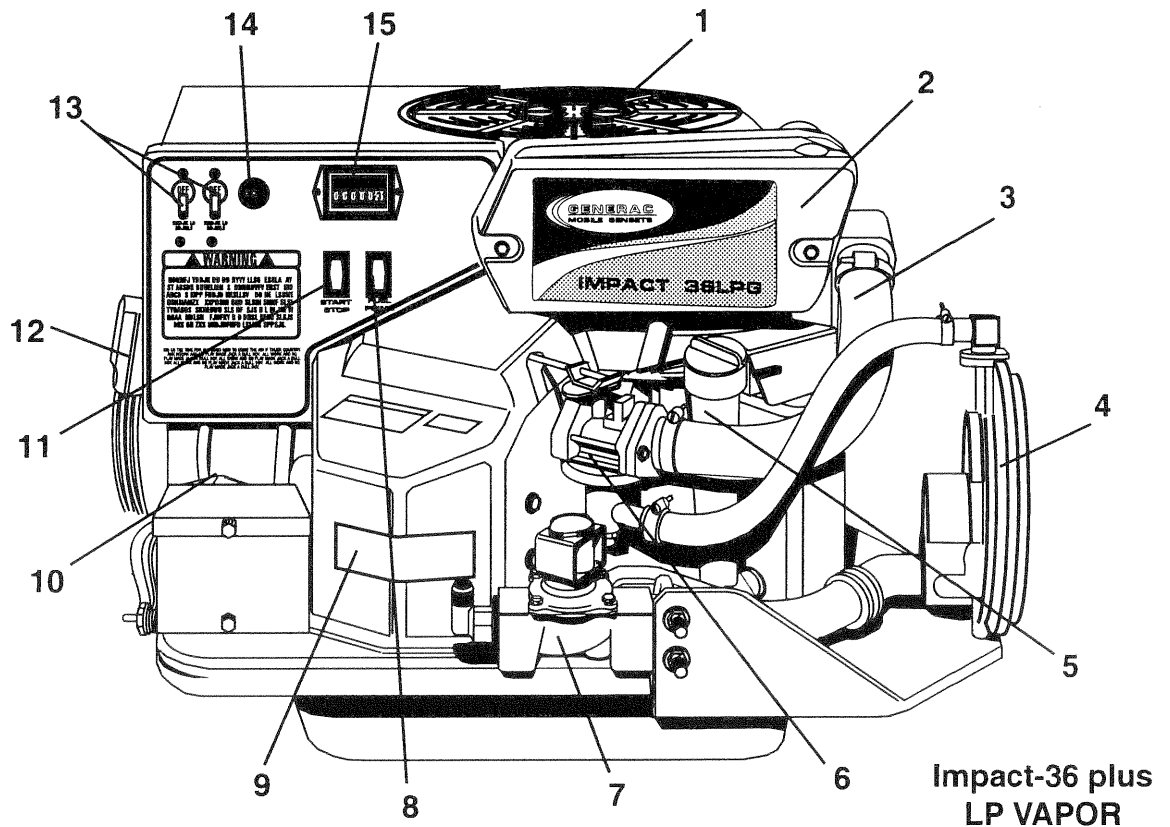

REFERENCE NUMBER IDENTIFICATION

1. Generator Air Intake Screen

9. Data Decal

2. Air Cleaner

10. 12 Volt Battery Connection

3. Air Intake Tube

11. Engine Start/Stop Switch

4. LP Fuel Regulator

12. Generator DC Output Leads

5. Oil Dipstick and Filler Tube

13. Circuit Breaker

6. LP Carburetor

14. Fuse

7. LP Fuel Solenoid

15. Hour Meter

8. Fuel Primer Switch

INVERTER FEATURES

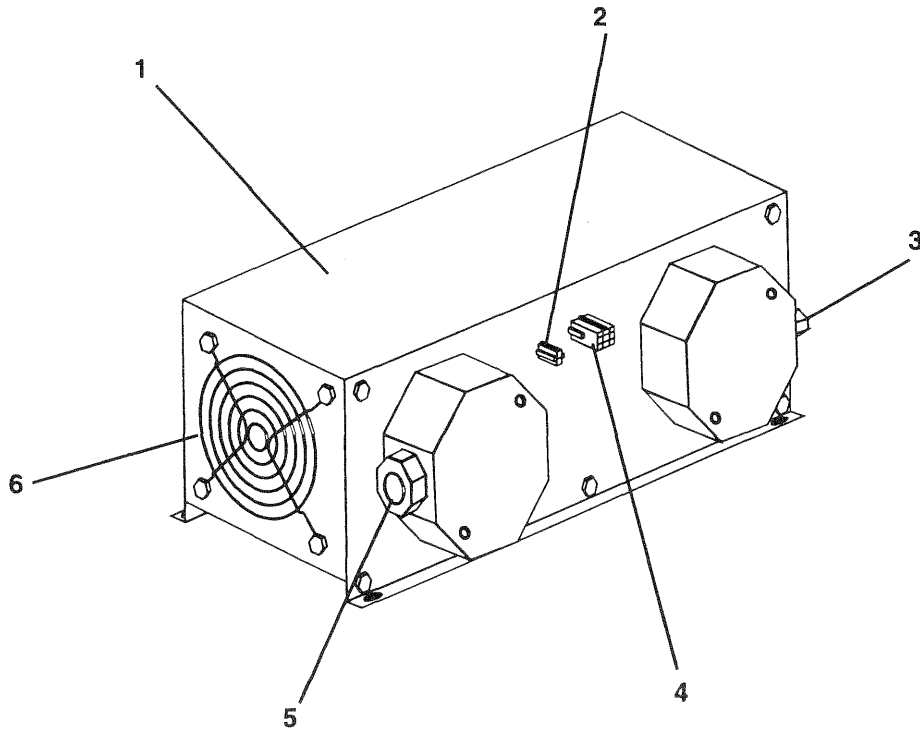

PART No. A6187 INVERTER

REFERENCE NUMBER IDENTIFICATION

- | | |
|-----------------------|---------------------|
| 1. Inverter | 4. 2 Pin Connection |
| 2. 9 Pin Connection | 5. DC Input |
| 3. Customer AC Output | 6. Cooling Fan |

READ THIS MANUAL THOROUGHLY

If you do not understand any portion of this manual, contact Generac or your nearest Generac Authorized Service Dealer for starting, operating and servicing procedures.

Throughout this publication and on tags and decals affixed to the generator, DANGER, WARNING, CAUTION and NOTE blocks are used to alert you to special instruction about a particular operation that may be hazardous if performed incorrectly or carelessly. Observe them carefully.

These safety warnings cannot eliminate the hazards that they indicate. Strict compliance with the special instructions while performing the service plus "common sense" are major measures to prevent accidents.

The following definitions apply to DANGER WARNING, CAUTION and NOTE blocks found throughout the manual.



DANGER: After this heading you can read handling, installing, operating or servicing instructions that, if not strictly complied with, will result in personal injury.



WARNING: After this heading you can read handling, installing, operating or servicing instructions that, if not strictly complied with, may result in personal injury.



CAUTION: After this heading you can read instructions for handling, installing, operating or servicing the generator that, if not strictly complied with, could result in damage to equipment and/or property.

NOTE: After this heading you can read explanatory statements that require special emphasis.

These symbols indicate the following:



Points out important safety information and, if not followed, could endanger personal safety and/or property of yourself and others.



Potential explosion hazard



Potential fire hazard



Potential electrical shock hazard

The operator (driver) is responsible for proper and safe use of the vehicle, equipment on the vehicle, and the safety of all vehicle occupants. We strongly recommend that the operator read this Owner's Manual and thoroughly understand all instructions before using this equipment. We also strongly recommend instructing other occupants in the vehicle to properly start and operate the generator. This prepares them if they need to operate the equipment in an emergency.

OPERATION AND MAINTENANCE

It is the operator's responsibility to perform all safety checks, to make sure that all maintenance for safe operation is performed promptly, and to have the equipment checked by an Authorized Dealer periodically. Normal maintenance service and replacement of parts are the responsibility of the Owner/Operator and, as such, are not considered defects in materials or workmanship within the terms of the warranty. Individual operating habits and usage contribute to the need for maintenance service.

Proper maintenance and care of your RV generator assures a minimum number of problems and keeps your operating expenses at a minimum. See your authorized Dealer/Distributor for service aids and accessories.

HOW TO OBTAIN SERVICE

When your RV generator set requires servicing or repairs, simply contact an Authorized Service Facility for assistance. Service technicians are factory-trained and are capable of handling all of your service needs.

When contacting an Authorized Service Facility or the factory about parts and service, always supply the complete model number and serial number of your unit as given on its data decal.

The warranty on your generator is included in this Owner's Manual, as well as listings for repair parts.

SERVICE DEALER LOCATION

TO LOCATE THE NEAREST GENERAC SERVICING DEALER, PLEASE CALL OUR 800 NUMBER.

ONLY DEALER LOCATION INFORMATION CAN BE OBTAINED AT THIS NUMBER.

1-800-333-1322

GENERATOR FAMILIARIZATION

GENERATOR APPLICABILITY

These generators have been designed and manufactured for supplying electrical power for recreational vehicles. You should not modify the generator or use it for any application other than for what it was designed. If there are questions pertaining to its application, write or call the factory. Do not use the unit until you have been advised by a competent authority.



DANGER: For fire safety, the generator must have been properly installed in compliance with (1) ANSI 119.2-1975/NFPA 501C-1974 "Standard for Recreational Vehicles", Part III, "Installation of Electrical Systems." The generator also must have been installed in strict compliance with the manufacturer's detailed installation instructions. After installation, do nothing that might render the unit in non-compliance with such codes, standards and instructions.

This generator has been designed to work with an inverter (P/N A6187). The inverter changes the voltage from the generator from a DC to an AC voltage. This generator will not operate properly without the inverter box connected. All repairs of the inverter must be handled by an authorized service dealer (see Page 12 in "Maintenance").

You can use this generator to supply electrical power for operating 120 volts, single phase, 60 Hertz, electrical loads. These loads can require up to 3400 watts (3.4 kW) for the Impact-34 plus, or 3600 watts (3.6 kW) for the Impact-36 plus. The maximum current at 120 volts is 28.3 amperes for the Impact-34 plus, or 30 amperes for the Impact-36 plus.



CAUTION: Do not overload the generator. Some installations may require that electrical loads be alternated to avoid overloading. Applying excessively high electrical loads may damage the generator and may shorten its life. Add up the rated watts of all electrical lighting, appliance, tool and motor loads the generator will power at one time. This total should not be greater than the wattage capacity of the generator. If an electrical device nameplate gives only volts and amps, multiply volts times amps to obtain watts (volts x amps = watts). Some electric motors require more watts of power (or amps of current) for starting than for continuous operation.

SAFETY

Before using the generator set, carefully read GENERAL SAFETY RULES inside the cover. Comply with these RULES to prevent accidents and damage to equipment and/or property. Generac suggests copying and posting the GENERAL SAFETY RULES in potential hazard areas of the recreational vehicle. Safety should be stressed to all operators of this equipment.

OPERATING INSTRUCTIONS

GENERATOR CONTROL PANEL

Mounted on the generator control panel (Figure 1) are the following features:

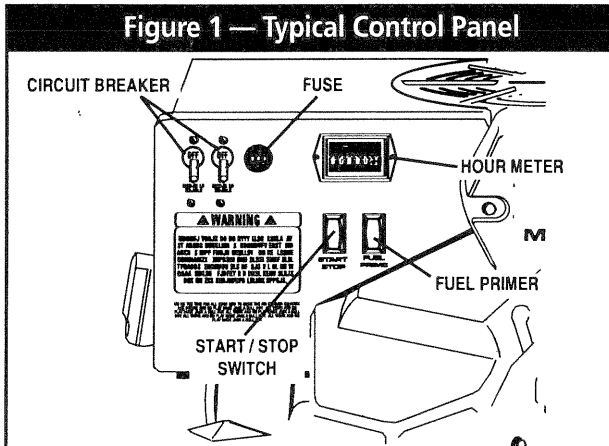

■ FUEL PRIMER

Before starting a cold engine (if it has not been started in more than two weeks), you must press this switch to bring fuel from the tank to the fuel carburetor. This rocker type switch springs back into its original position when you release it.

■ START/STOP SWITCH

To crank and start the engine, hold this switch at its START position. Release the switch when the engine starts. To stop an operating engine, press and hold the switch in its STOP position until the engine shuts off. The switch center position is the RUN position.

■ FUSE

Protects the engine DC control circuit against electrical overload. If the fuse element has melted open due to overloading, the engine cannot be cranked. If you must replace it, use only an identical replacement fuse.

■ CIRCUIT BREAKERS

Protects generator's AC output circuit against overload, i.e., prevents unit from exceeding wattage/ampere capacity.

■ HOUR METER

Indicates the time the engine-generator has operated, in hours and tenths of hours. Use the hourmeter along with the periodic maintenance schedule for your generator set.

AUTOMATIC CHOKE (GASOLINE ONLY)

The engine is equipped with an automatic choke (not shown) that consists of two main components — choke solenoid and prechoke.

■ CHOKE SOLENOID (GASOLINE ONLY)

During engine cranking (start/stop switch at START), a solid state control circuit board signals the choke solenoid to actuate and cycle (choke on/choke off) until engine starts. The choke solenoid thus opens and closes the carburetor choke valve only when the engine is cranking. When the engine starts, the choke cycling stops.

■ PRECHOKE (GASOLINE ONLY)

The choke system also has a temperature sensitive metal strip that adjusts the choke valve angle according to ambient temperatures (i.e., in cold ambient temperatures the choke valve closes more). Once the engine starts, an element heats the temperature-sensitive strip to a normal operating condition, opening the choke valve. This may take about 3 minutes in cooler weather.

BEFORE STARTING THE ENGINE

IMPORTANT: INSTRUCTIONS AND INFORMATION IN THIS MANUAL ASSUME THE GENERATOR HAS BEEN PROPERLY INSTALLED, CONNECTED, SERVICED, TESTED AND ADJUSTED BY A QUALIFIED INSTALLATION TECHNICIAN OR INSTALLATION CONTRACTOR.

■ INSTALLATION

Generator installation must have been properly completed so it complies with all applicable codes, standards and regulations and with the manufacturer's recommendations.

■ ENGINE LUBRICATION

Have engine crankcase properly serviced with recommended oil before starting. Refer to "Maintenance" and "Specifications" sections for oil servicing procedures and recommendations.

CAUTION: Any attempt to crank or start the engine before you have properly serviced it with the recommended oil may result in engine failure.

■ FUEL SUPPLY

The engine must have adequate supply of proper fuel to operate. Before starting, check that sufficient fuel is available.

NOTE: On some gasoline installations, the generator engine may "share" the vehicle's gasoline fuel tank with the vehicle engine. Some installations may provide separate fuel tanks for generator and vehicle engine.

■ COOLING AND VENTILATING AIR

Air inlet and outlet openings in the generator compartment must be open and unobstructed for continued proper operation. Without sufficient cooling and ventilating air flow, the engine-generator quickly overheats, which causes it to automatically shutdown. Overheating could also damage the unit or your vehicle.

■ ENGINE EXHAUST GAS

Before starting the generator engine, you should be sure there is no way for exhaust gases to enter the vehicle interior and endangering people or animals. Close windows, doors and other openings in the vehicle that, if open, might permit exhaust gases to enter the vehicle.



DANGER: The generator engine gives off deadly carbon monoxide gas through its exhaust system. This dangerous gas, if breathed in sufficient concentrations, can cause unconsciousness or even death. Do not operate the generator if its exhaust system is leaking or has been damaged. Symptoms of carbon monoxide poisoning are (a) inability to think coherently, (b) vomiting, (c) twitching muscles, (d) throbbing temples, (e) dizziness, (f) headache, (g) weakness and sleepiness. If you feel any of these symptoms, move into fresh air immediately. If symptoms persist, get medical help.

STARTING

IMPORTANT: Read the vehicle manufacturer's instructions. The owner/operator should become familiar with the vehicle in which this generator is installed. Differences exist between vehicles. For example, some vehicles may use a transfer switch to isolate dockside power from the generator, while other vehicles may use an isolating receptacle. Some vehicles may be equipped with a DC converter which allows the generator to power certain DC lighting and other DC loads.

To crank and start the generator engine, proceed as follows:

1. Turn OFF electrical loads, using whatever means provided in your vehicle (such as a main line circuit breaker or transfer switch).

NOTE: If you start the engine with the start/stop switch on the generator control panel, turn OFF loads by setting the panel's main breaker to its "OFF" or "OPEN" position. Electrical load circuits may be turned ON after the generator has started, stabilized and warmed up.

NOTE: On gas units you only need to use the fuel primer during the initial startup, after the unit has not been used for an extended period of time (two weeks) or the fuel line has been disconnected. The primer is used to prime the fuel pump and carburetor.

2. To crank and start the engine, hold the start/stop switch at START. Release the switch when the engine starts.



CAUTION: If the engine does not start after it has been cranking for 15 seconds, release the start/stop switch and try again. Holding the switch for longer than 15 seconds may damage the starter motor.

3. Let the engine run at no-load for a few minutes to stabilize and warm up the engine.

4. Turn ON electrical loads, using whatever means provided (such as a main circuit breaker or transfer switch).

NOTE: If you start a warm generator engine, you may press the start switch only slightly to engage the ignition system. However, you should press and hold the starter switch for a minimum of two (2) seconds to energize the field boost system. If you start the engine without energizing the field boost system, the generator produces no output.

STOPPING THE GENERATOR

1. Turn OFF all electrical loads, using whatever means provided (such as a main circuit breaker or transfer switch).
2. Let the generator run at no-load for a few minutes, to stabilize internal engine-generator temperatures.
3. Hold Start/Stop switch in its STOP position.

APPLYING LOADS TO GENERATOR

When applying electrical loads to the generator, observe these guidelines:

- Before applying electrical loads, let the generator stabilize and warm up for a minute or two.
- DO NOT overload the generator.

■ LETTING ENGINE STABILIZE

The generator supplies correctly rated frequency and voltage only at the proper governed speed. Some electrical appliances may be extremely sensitive to voltage and frequency. Incorrect frequencies and/or voltages can damage those appliances.

If electrical loads are applied at reduced operating speeds, such loads imposed on the engine when sufficient power is not available may shorten engine life. Never turn ON electrical loads until after the generator engine has started and stabilized ON-speed.

ATTENTION REQUIRED AFTER SUBMERSION

If the motor home generator has been submerged in water, it must NOT be started or operated. Following any submersion in water, have an authorized Generac Service Facility thoroughly clean and dry the generator.

OPERATION IN HIGH GRASS OR BRUSH

Never operate the generator while the vehicle is parked in high grass, weeds, brush or leaves. Such materials can ignite and burn from the heat of the exhaust system. The generator exhaust system becomes extremely hot during operation and remains hot for a long time after it has shut down.

OPERATING PRECAUTIONS

Never operate the motor home generator set while the vehicle is parked over dry leaves, dry grass or any other combustible substance. The generator's exhaust system becomes extremely hot and can cause a fire if it is too close to combustible materials.

The generator's exhaust system gives off DEADLY carbon monoxide gas. This dangerous gas, if breathed in sufficient concentrations, can cause unconsciousness and even death. Never operate the generator set with the vehicle inside any garage or other enclosed area. Never operate the generator if it has a leaky exhaust system. Close windows in the vicinity of the generator exhaust outlet and take any other steps to prevent exhaust gases from entering rooms or areas occupied by people or animals.

EFFECTS OF MOISTURE AND DIRT

Keep the generator set as clean and dry as possible. Protect unit against excessive dust, dirt, corrosive vapors, road splash, etc. Permitting dirt and moisture to accumulate on generator windings will have an adverse effect on the insulation resistance of those windings.

When moisture is allowed to remain in contact with windings, some of the moisture will be retained in voids and cracks in the insulation. This causes a reduced insulation resistance and will eventually cause problems. Dirt will make the problem worse, since dirt tends to hold moisture in contact with windings. Salt (as from sea air) will also worsen the problem since it tends to absorb moisture from the air. Salt and moisture, when combined, form a good electrical conductor.

DO NOT OVERLOAD THE GENERATOR

You can read the rated wattage/amperage capacity of your generator on the generator data decal (see "Identification Record" on Pages 2-3).

Applying electrical loads in excess of the unit's rated capacity will cause the engine-generator to automatically shutdown.

To avoid overloading, add up the wattage of all connected electrical lighting, appliance, tool and motor loads. This total should not be greater than the generator's rated wattage capacity.

- Most lighting, appliance, tool and motor loads indicate their required watts on their nameplate or data plate. For light bulbs, simply note the wattage rating of the bulb.
- If a load does not show its rated wattage, multiply that load's rated VOLTS times AMPS to obtain WATTS.
- Induction type motors (such as those that run the vehicle's furnace fan, refrigerator, air conditioner, etc.) need about 2-1/2 times more watts of power for starting than for running (for a few seconds during motor starting). Be sure to allow for this when connecting electrical loads to the generator. First, figure the watts needed to start electric motors in the system. To that figure, add the running wattages of other items that will be operated by the generator.
- On a new generator do not apply heavy electrical loads for the first two or three hours of operation.

ENGINE PROTECTIVE DEVICES

This generator has a computer that monitors low oil pressure, oil temperature, engine speed, and low voltage output. This section discusses those protective devices.

AUTOMATIC LOW OIL PRESSURE SHUTDOWN

The engine is equipped with an oil pressure sensor that shuts down the engine automatically when oil pressure is too low. If the engine shuts down by itself and the fuel tank has enough fuel, check the engine oil level.

INITIAL STARTUP

During initial startup, a time delay built into the shutdown control system allows oil pressure to build. The delay allows the engine to run for about 10 seconds before sensing oil pressure.

SENSING LOW PRESSURE

If the system senses low oil pressure during operation, the engine shuts down. If you do restart the engine after a low oil pressure shutdown and have not corrected the low oil level, the engine runs for about 10 seconds as described above then stops.

HIGH TEMPERATURE SHUTDOWN

A temperature switch with normally-open (N.O.) contacts is mounted near the oil filter. If engine temperature were to exceed a preset temperature, the switch contacts close and the engine shuts down.

OVERSPEED

If engine speed is increased manually (or otherwise) beyond the control of the computer control system, the computer disables the load capability of the generator and shuts down the engine.



WARNING: Do not attempt to physically adjust or control the engine speed. Equipment damage or personal injury may result.

LOW VOLTAGE

The computer monitors the voltage output of the generator. If voltage sensors indicate that voltage has dropped below a preset level, the engine will automatically shut down. Once the unit has shutdown, the computer is automatically reset when you restart the engine.

NOTE: The computer allows for the low voltage output that occurs during startup. A time delay that allows the engine to start and warm up is programmed into the monitoring system.



CAUTION: Before restarting a generator that has been shutdown, disconnect all loads the generator might power by whatever means provided, such as the recreational vehicle's main circuit breaker.

SPECIFICATIONS

FUEL REQUIREMENTS (GASOLINE UNITS)

These generators are equipped with gasoline fuel systems as standard equipment. Specific installations may provide either a separate fuel tank for the generator, or the generator may "share" the vehicle engine's fuel tank.

NOTE: Installations using a "shared" fuel tank may have a generator fuel pickup tube that is shorter than the vehicle engine's pickup tube. Such an arrangement causes the generator engine to "run out of gas" while adequate fuel for the vehicle remains in the tank.

To reduce lead and carbon deposits use high quality UNLEADED gasoline with the generator. Leaded REGULAR grade gasoline is an acceptable substitute.

NOTE: Using "Unleaded" gasoline contributes to longer engine valve life by reducing lead and carbon deposits.



CAUTION: Generac does not recommend using any gasoline containing alcohol, it must not contain more than 10 percent ethanol and it must be removed from the generator during storage. Do NOT use any gasoline containing methanol. If you use gasoline with alcohol, inspect more frequently for fuel leaks and other abnormalities.

FUEL CONSUMPTION (IN GALLONS PER HOUR):

LOAD	GASOLINE	LP
NO	0.14	0.20
HALF	0.32	0.41
FULL	0.54	0.77

FUEL REQUIREMENTS (LP UNITS)

These generators are equipped with a liquefied petroleum (LP) gas fuel system. LP gas is usually supplied as a liquid in pressure tanks.

These generators require a "vapor withdrawal" type fuel system. This type of gaseous fuel system uses the vapors forming above the liquid fuel in the storage tank. Air temperature around the storage tank must be high enough to sustain adequate fuel vaporization. In colder climates, you may need to use an independent heat source to be sure the fuel sufficiently vaporizes in the storage tank.

LP gas may consist of propane, butane or a mixture of the two gases. Propane vaporizes at temperatures as low as -20°F (-29°C), but butane returns to its liquid state when the temperature drops below about 32°F (0°C). For that reason, a higher ratio of propane is desired in the gas mixture when temperatures drop below freezing.

ENGINE OIL REQUIREMENTS

The recommended oils include the following:

- During summer months: SAE 30. An acceptable substitute is SAE 10W-30.
- During winter months: SAE 5W30. DO NOT USE SAE 10W-40.

Crankcase and oil filter capacity is about 950ml or one (1) quart. Use no special additives. See "Maintenance" section for oil level check and fill procedures.

GAS GENERATOR SPECIFICATIONS

Model..... Impact-36G plus
 Rated Maximum Continuous
 AC Power Output 3600 watts (3.6 kW)
 Rated Voltage 120 volts AC
 Rated Maximum Continuous
 Current at 120 volts 30 AC amperes
 Phase..... Single Phase
 Rated AC Frequency 60 Hz.
 Recommended Battery
 Cranking Current 400 amps
 Gross Weight..... 86 lbs
 Maximum Cranking Current.....250 Amps
 Maximum Charging Current.....2 Amps

LP GENERATOR SPECIFICATIONS

Model..... Impact-36LPG plus
 Rated Maximum Continuous
 AC Power Output 3400 watts (3.4 kW)
 Rated Voltage 120 volts AC
 Rated Maximum Continuous
 Current at 120 volts 28.3 AC amperes
 Phase..... Single Phase
 Rated AC Frequency 60 Hz.
 Recommended Battery
 Cranking Current 400 amps
 Gross Weight..... 87 lbs
 Maximum Cranking Current.....250 Amps
 Maximum Charging Current.....2 Amps

ENGINE SPECIFICATIONS

Type of Engine GN-220
 Cooling Method..... Air-cooled
 Displacement..... 220cc
 Type of Governor Electronic
 Air Cleaner..... Paper element
 Starter 12 volt DC electric
 Ignition System..... Solid state
 Recommended Spark Plugs..... Champion RC12YC
 Spark Plug Gap..... 0.030 inch (0.8mm)

This section includes information about simple maintenance which includes the following tasks:

- Checking engine oil level.
- Changing engine oil.
- Changing oil filter.
- Air cleaner maintenance.
- Cleaning the air intake screen.
- Cleaning spark arrestor.
- Cleaning spark plug.
- Replacing fuel filter.
- Servicing inverter.

CHECKING ENGINE OIL LEVEL

Check engine crankcase oil level at least every eight hours of operation, or before each use (Figure 2).

- Be sure the generator is as level as possible.
- Remove oil dipstick and wipe dry with clean, lint-free cloth.
- Install and tighten oil dipstick, then remove again.
- Oil should be at dipstick FULL mark. If necessary, add the recommended oil to the FULL mark only. **DO NOT FILL ABOVE "FULL" MARK.**
- Install and tighten oil dipstick cap before operating the engine.

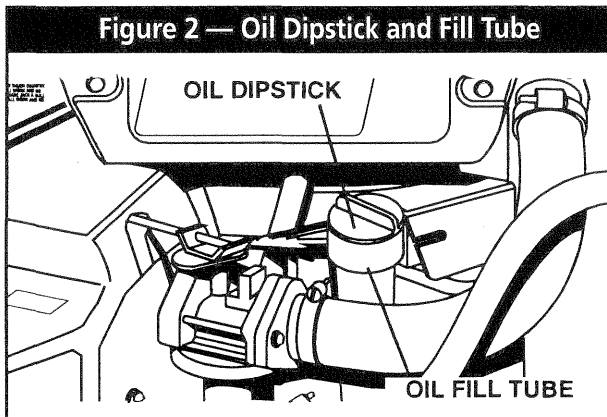

NOTE: See "Engine Oil Requirements" on Page 10 for recommended oils.

CHANGE ENGINE OIL

Change engine oil after the first 8 hours of operation. Thereafter, change oil every 50 operating hours. Change oil more frequently if operating consistently under heavy load or at high ambient temperatures.

- Warm up engine for at least five minutes, then shut down.
- With engine still warm from running, clean area around oil drain plug and remove oil drain plug (Figure 3). Drain oil completely into a suitable container.
- When oil has drained, install and tighten drain plug.

- Remove oil dipstick and fill crankcase with the recommended oil (See Page 10). The engine crankcase can hold about 1 quart (950ml). **DO NOT FILL ABOVE "FULL" MARK.**
- Install and tighten dipstick cap before operating engine.

CHANGE OIL FILTER

Replace the engine oil filter after the first 8 hours of operation, every 100 operating hours thereafter.

- Turn oil filter counterclockwise to remove (Figure 3).

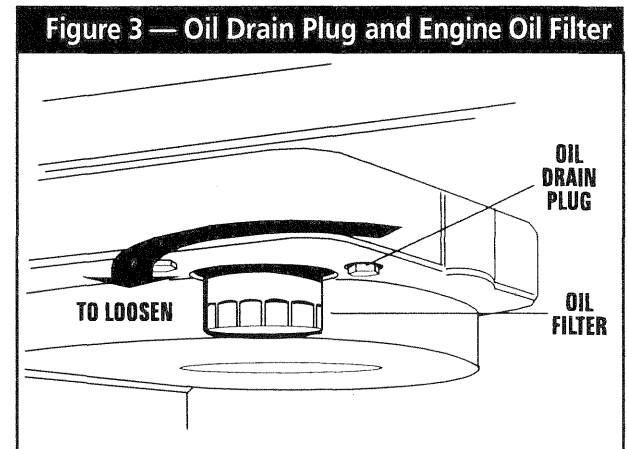

- Coat gasket of new filter with engine oil.
- Turn new filter clockwise until its gasket contacts lightly with the filter adapter. Then tighten an additional 3/4 to one turn by hand.
- Run engine and check for leaks.

NOTE: Check oil level and fill to full mark after checking for leaks. Filter will retain some oil.

ENGINE AIR CLEANER

Paper Filter: Once every 25 operating hours or once each year (whichever comes first), clean or replace the paper filter (Figure 4). Follow the steps on page 12.

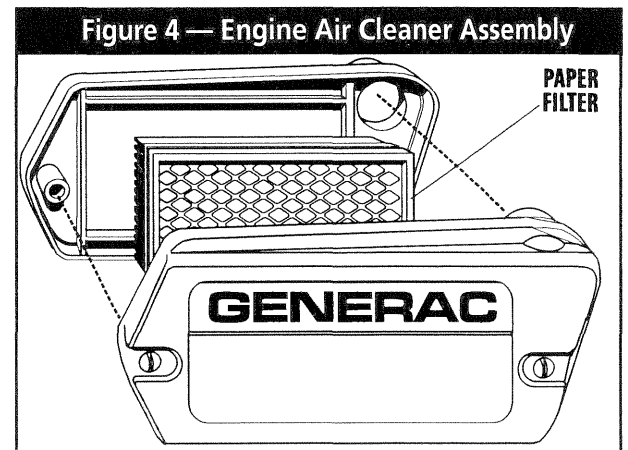

- Remove air cleaner cover, then remove paper filter.
- Clean air filter by gently tapping it on a solid surface. If the filter is too dirty, replace it with a new one. Dispose of the old filter properly.
- Clean air cleaner cover then insert new paper filter into cover and assemble to the base of the air cleaner.

CLEAN AIR INTAKE SCREEN

Clean all foreign material from the air intake screen (Figure 5) at least once every 100 hours of operation. Clean more often if necessary.

Inspect the area around the generator exhaust muffler periodically and remove all grass, leaves, dirt, etc. from this area.

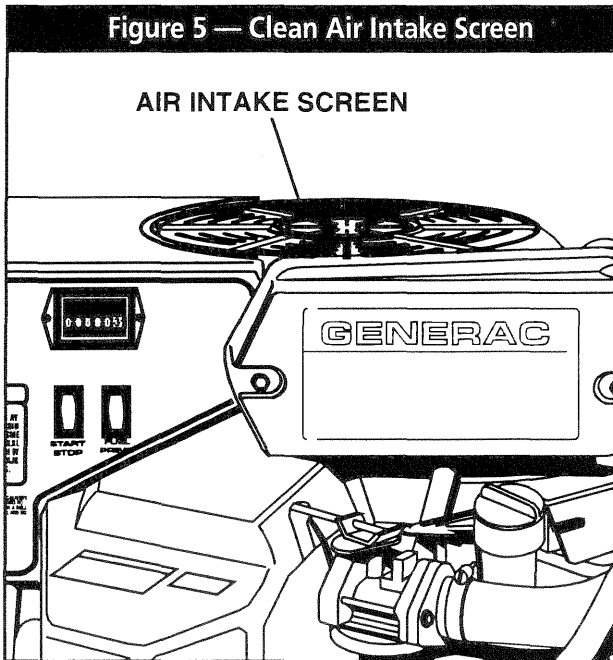

ENGINE SPARK PLUG

Clean engine spark plug and set gap to 0.030 inch (0.76mm) every 100 hours of operation (Figure 6). Clean by scraping or wire brushing and washing with commercial solvent. DO NOT BLAST CLEAN SPARK PLUG.

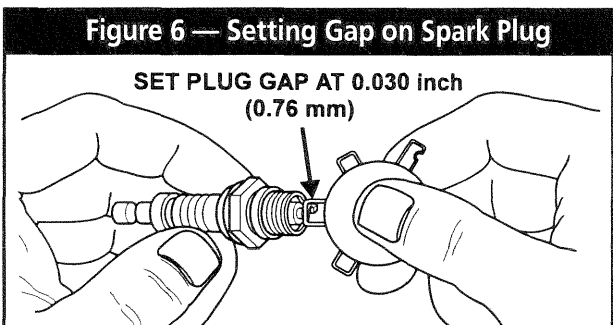

CAUTION: Sparking can occur if wire terminal does not fit firmly over spark plug terminal end. If necessary, reform wire terminal to obtain a tight fit.

FUEL FILTER

Remove and replace fuel filter (Figure 7) every 100 hours of operation or once each year, whichever occurs first.

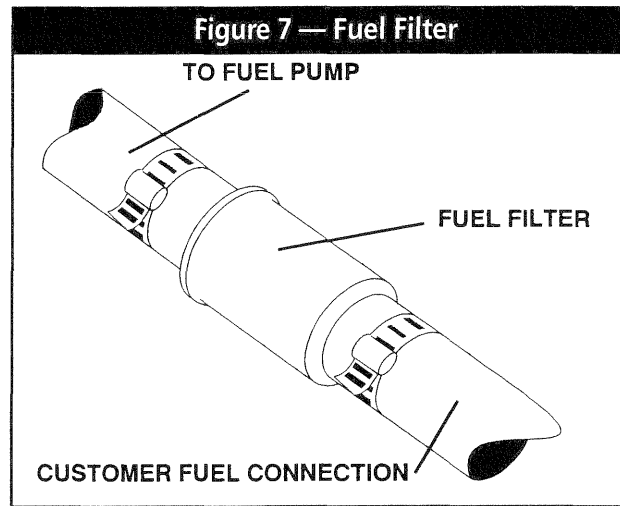

INVERTER

All repairs of the inverter **MUST** be handled by an authorized service dealer (see Figure 8).

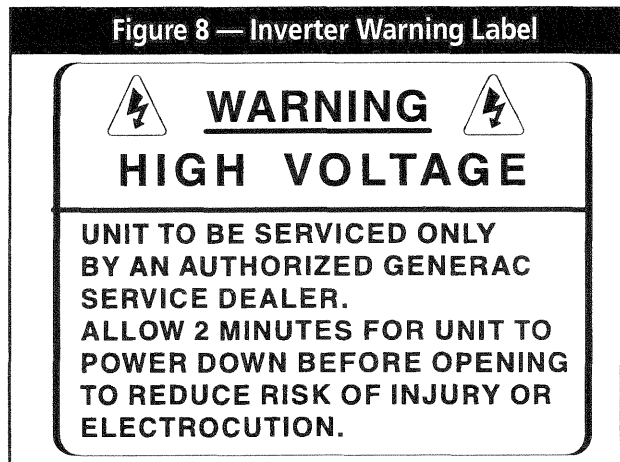

CLEANING THE GENERATOR

Keep your generator set as clean and dry as possible. Dirt and moisture that are permitted to accumulate on electrical windings have an adverse affect on the insulation resistance of those windings.

Moisture that is allowed to remain in contact with windings will be retained in voids and cracks of the windings. Dirt makes the problem worse, since it tends to hold the moisture into contact with the windings. Salt, as from sea air, worsens the problem since it tends to absorb moisture from the air. The combination of salt and moisture makes a good electrical conductor.

CAUTION! Do NOT use a forceful spray of water to clean the generator. Water will enter the generator interior and cause problems, and may also contaminate the generator fuel system.

BATTERY

All lead-acid storage batteries will discharge when not in use. Inspect the generator battery as follows:

■ ONCE WEEKLY

Inspect battery posts and cables for tightness, corrosion. Clean and/or tighten as necessary.

Also check battery fluid level, and, if necessary, fill with DISTILLED WATER ONLY. DO NOT USE TAP WATER IN BATTERY.

■ EVERY SIX MONTHS

Have the battery state of charge and condition checked by an automotive service facility. This should be done with an automotive type battery hydrometer.



DANGER: Storage batteries give off explosive hydrogen gas. This can form an explosive mixture around the battery for several hours after charging. The slightest spark can ignite the gas and cause an explosion. Such an explosion can shatter the battery and cause blindness or other injury. Any area that houses a storage battery must be properly ventilated. Do not allow smoking, open flame, sparks or any spark producing tools or equipment near the battery.



DANGER: Battery electrolyte fluid is an extremely caustic sulfuric acid solution that can cause severe burns. Do not permit fluid to contact eyes, skin, clothing, painted surfaces, etc. Wear protective goggles, protective clothing and gloves when handling a battery. If you spill the fluid, flush the affected area immediately with clear water.



DANGER: Do not use any jumper cables or booster battery to crank and start the generator engine. If any battery has discharged, remove it from the vehicle for recharging.

SERVICE AND ADJUSTMENTS

■ ENGINE SPEED

Engine speed is completely computer-controlled. There is no adjustment for speed on the unit. The computer adjusts the engine speed using an electronic governor throttle control. The computer monitors the demand for power and adjusts the engine speed accordingly. This allows the engine to produce only the power required, resulting in fuel economy as well as lowering the overall noise emitted.

NOTE: The computer will disable the electrical load capabilities of the generator and enter a fault condition if you accelerate the throttle manually or any other way.

ADJUSTING THE CARBURETOR

The carburetor of your generator is preset at the factory. The carburetor should not be tampered with, as this will void the emission control system warranty. If your generator is used at altitudes in excess of 5,000 feet, consult your Generac Authorized Service Facility regarding high altitude jetting changes.

ADJUSTING VALVE CLEARANCE

After the first 50 hours of operation, you should adjust the valve clearance in the engine.

When adjusting valve clearance, the engine should be at room temperature and the piston should be at Top Dead Center (TDC) of its compression stroke (both valves closed). Correct clearance is 0.001-0.003 inch (0.03-0.07mm). Adjust valve clearance as follows:

1. Loosen the rocker arm jam nut. Use an allen wrench to turn the pivot ball stud while checking clearance between the rocker arm and the valve stem with a feeler gauge (Figure 11).

Figure 11 — Adjusting Valve Clearance

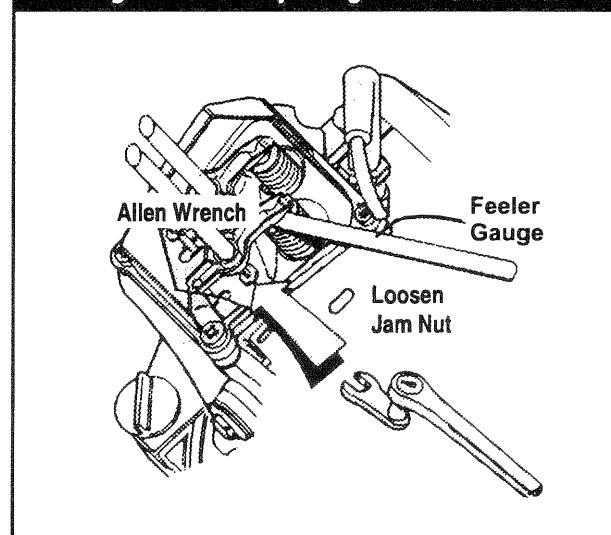

2. When valve clearance is correct, hold the pivot ball stud with the allen wrench and tighten the rocker arm jam nut with a crows foot. Tighten the jam nut to 65-85 inch-pounds torque. After tightening the jam nut, recheck valve clearance to make sure it did not change (Figure 12 on page 13).

Figure 12 — Tightening Jam Nut

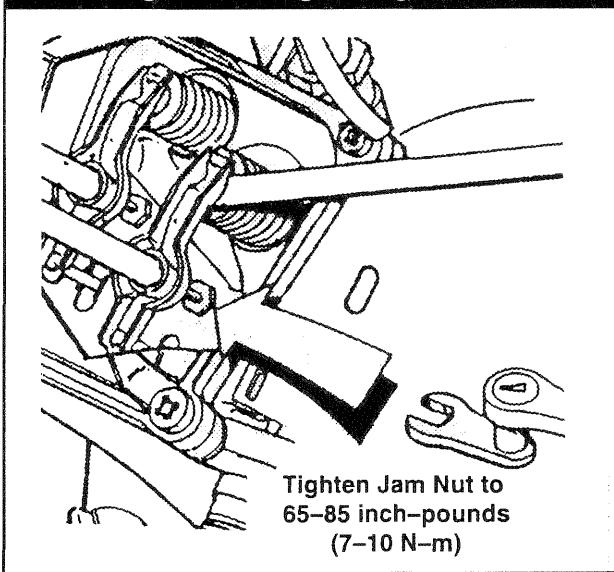

MAJOR SERVICE MANUAL

To obtain a service manual for your generator, order it from your dealer/distributor or contact the factory. Be sure to identify your unit's MODEL NUMBER and SERIAL NUMBER.

EXERCISING THE GENERATOR

Generac recommends that you start and operate the generator at least once every seven days. Let the unit run for at least 30 minutes to "exercise" the engine.

OUT OF SERVICE PROTECTION

If you cannot exercise the generator every seven days and it is to be out of service longer than 30 days, prepare the generator for storage as follows:

- Start the engine and let it warm up.
- While the engine is still warm from running, drain the oil completely. Refill crankcase with recommended oil. See "Specifications."

- Attach a tag to the engine indicating the viscosity and classification of the oil in the crankcase.
- Remove spark plug and add about 1/2 ounce (15ml) of clean, fresh engine oil into spark plug threaded opening. Crank engine several times to distribute oil, then install and tighten spark plug.
- Remove the battery and store in a cool, dry room on a wooden board. Never store the battery on any concrete or earthen floor.
- Clean and wipe the entire generator.

RETURN UNIT TO SERVICE AFTER STORAGE

To return the unit to service after storage, proceed as follows:

- Check tag on engine for oil viscosity and classification. Verify that the correct recommended oil is used in engine. If necessary, drain and refill with proper oil.
 - Check battery. Fill all cells to the proper level with distilled water. DO NOT USE TAP WATER IN THE BATTERY. Recharge battery to 100% state of charge, or, if defective, replace the battery.
 - Turn OFF all electrical loads, then start the engine.
 - Let engine warm up.
 - Apply electrical loads to at least 50% of the unit's rated wattage capacity.
 - When engine is thoroughly warmed up, shut it down.
- THE GENERATOR IS NOW READY FOR SERVICE.

SERVICE DEALER LOCATION

TO LOCATE THE NEAREST GENERAC SERVICING DEALER, PLEASE CALL OUR 800 NUMBER.

ONLY DEALER LOCATION INFORMATION CAN BE OBTAINED AT THIS NUMBER.

1-800-333-1322

INSTALLATION SAFETY RULES



DANGER: FOR FIRE SAFETY, INSTALLATION OF A GENERATOR INTO A RECREATIONAL VEHICLE MUST COMPLY STRICTLY WITH ARTICLE 551, NFPA 70; ANSI C1-1975; AND, ANSI A119.2-1975/NFPA 501C "STANDARD FOR RECREATIONAL VEHICLES" (PART 3, "INSTALLATION OF ELECTRICAL SYSTEMS"). IN ADDITION, THE MANUFACTURER'S INSTRUCTIONS AND RECOMMENDATIONS MUST BE COMPLIED WITH.



NOTICE TO INSTALLER

The Installation Instructions have been published by Generac to aid in the installation of the products described in this manual. Generac assumes that installation personnel are familiar with the procedures for installing such products, or similar products that Generac manufactures. Generac also assumes that personnel have been trained in the recommended installation procedures for these products and that such training includes (a) use of common hand tools, (b) use of special Generac tools, and (c) use of any tools and/or equipment from other suppliers.

We could not possibly know of and advise the recreational vehicle trade of all conceivable methods, procedures or techniques by which to perform an installation. We could not know of the possible hazards that might result from each installation method, procedure or technique. We have not undertaken any such wide evaluation. Therefore, people who use a method, procedure or technique that Generac does not specifically recommend must first completely satisfy themselves that their safety, the safety of the vehicle's occupants and the product's safety is not endangered by the method, procedure or technique selected.

Information, illustrations, specifications, etc., contained in this Installation Manual are based on the latest information available at the time of publication. Every effort has been expended to be sure that such data is both accurate and current. However, the manufacturer reserves the right to change, alter or otherwise improve this product at any time without prior notice.

SAFETY RULES

- ▲ Gasoline is extremely **FLAMMABLE** and its vapors are **EXPLOSIVE**. Do not permit smoking, open flame, sparks or any source of heat in the vicinity while handling gasoline. Comply with all laws governing the storage and handling of gasoline.
- ▲ Fuel lines must be properly installed, properly fastened and free of leaks. There must be no possibility of gasoline vapors entering vehicle interior.
 - You are required to install an approved, flexible, non-conductive fuel line between the generator fuel connection point and rigid fuel lines.
- ▲ If the generator can be equipped with a liquid propane (LP) gas fuel system, install the unit so it complies with all codes, standards and regulations pertaining to such systems. LP gas is highly explosive. The gas tends to settle in low areas where even the slightest spark can ignite it and cause an explosion. Do not allow gas vapors to enter the vehicle.
 - Engine exhaust gases contain **DEADLY** carbon monoxide gas. This dangerous gas, if breathed in sufficient concentrations, can cause unconsciousness or even death. Install the exhaust system in strict compliance with applicable codes, standards and regulations. There must be no possibility for exhaust gases entering the vehicle interior and

endangering people or animals.

- ▲ The generator set produces dangerously high electrical voltage. Contact with bare wires, bare terminals, etc., will result in extremely hazardous and possibly lethal electrical shock.
 - All applicable electrical codes, standards and regulations must be strictly complied with in the installation and use of this equipment.
 - The generator must be properly grounded (bonded) to the vehicle chassis or frame.
- ▲ If the vehicle electrical circuits can be powered by any other source of electricity (such as a "dockside" power receptacle), there must be no possibility of connecting the different power sources to the vehicle circuits at the same time. The "dockside" (utility) power source must be positively isolated from the vehicle circuits whenever the generator is operating. Failure to isolate the vehicle circuits from the dockside power supply when the generator is running may result in damage to the generator or serious injury or death to dockside (utility) power workers due to backfeed of electrical energy.
 - Never work on the equipment while standing in water, while barefoot, or while hands or feet are wet. Dangerous electrical shock will result.
 - Jewelry conducts electricity, which can cause dangerous electrical shock. Remove all jewelry (such as rings, watches, or bracelets) before working on this equipment.
- ▲ The generator requires an adequate flow of air for cooling and ventilation. Without sufficient cooling air flow, the engine-generator quickly overheats, which causes serious damage to the generator, a fire or an explosion. Generator air inlet and outlet openings must be provided in strict compliance with the manufacturer's recommendations.
 - Never work on this equipment while physically or mentally fatigued. Stay alert at all times.
- ▲ Storage batteries give off **EXPLOSIVE** hydrogen gas while charging. The battery used for cranking and starting this generator should be installed in its own vented compartment. Provide adequate ventilation for the battery, to prevent explosive hydrogen gas from accumulating.
- ▲ Never insert any tool or other object through openings in the generator interior, even if the unit is not running. You might seriously injure yourself or damage the equipment.
 - Staying alert and using "common sense" are major measures for preventing accidents.

GENERAL INSTALLATION INFORMATION

PURPOSE AND SCOPE OF MANUAL

These Installation Instructions have been prepared especially for the purpose of familiarizing installers and owners of the applicable equipment with the product's installation requirements. Give serious consideration to all information and instructions in the Manual, both for safety and for continued reliable operation of the equipment.

Because of the different recreational vehicle models and the variations between the models, it would be extremely difficult, if not impractical, to provide detailed instructions on every installation possibility. For that reason, instructions and illustrations in this manual are general in nature. Illustrations are not intended to serve as detailed installation blueprints.

The installation should comply strictly with all applicable codes, standards and regulations pertaining to the installation and use of this product. If any portion of this manual appears to be in conflict with such codes, standards or regulations, the applicable codes, standards or regulations must take precedence over the manual.

SAFETY

Before handling, installing, operating or servicing this equipment, be sure to read carefully the "Notice to Installer" and "Safety Rules" at front of this manual. Comply with all SAFETY RULES to prevent death, personal injury or damage to equipment and/or property. Stress safety to all installers, operators and service technicians who work on this equipment.

STANDARDS BOOKLETS

Installation, use and servicing of this equipment should comply strictly with published standards, as well as the manufacturer's recommendations. The following standards booklets (latest revision) are available from the sources indicated:

1. NFPA Standard 501C, "Standard for Recreational Vehicles", available from the National Fire Protection Association, Batterymarch Park, Quincy, MA 02269.
2. NFPA 70, "NFPA Handbook of the National Electric Code", obtained from same address as Item 1.

3. ANSI C1-1975 and ANSI 119.2-1975, available from the American National Standards Institute, 1430 Broadway, New York, NY 10018.
4. ANSI A119.2/NFPA 501C, available from the Recreational Vehicle Association, 1896 Preston White Drive, Reston, VA 22090.
5. California Administrative Code, Title 25, available from the State of California, Documents Section, P.O. Box 1015, North Highlands, CA 95660.
6. CSA Electrical Bulletin 946, available from the Canadian Standards Association, Housing and Constructions Materials Section, 178 Rexdale Boulevard, Rexdale, Ontario, Canada, M9W 1R3.

EQUIPMENT DESCRIPTION

Instructions and information in this section pertain to Generac Impact air-cooled generators — more specifically, the installation of Impact-34 plus and Impact-36 plus recreational vehicle generators. These generators are designed specifically for installing in recreational vehicles.

ENGINE GENERATOR OPERATING SPEED

The generators are driven by gasoline-powered, single-cylinder engines. The engines drive revolving fields (rotors), high frequency, permanent magnet alternators. The generators supply 120 volts AC at 60 Hertz with DC inverter. The generators revolving fields are driven at a variable speed depending on the demand for power. Computers monitor that demand and adjust the engine speed to provide adequate power to the connected loads.

LOCATION AND SUPPORT

GENERATOR LOCATION

The most desirable location for the generator set is between the vehicle's main frame members. However, this is seldom possible. Most units must be installed on the side of the vehicle and are difficult to reinforce.

Many recreational vehicles have been factory equipped with an area for the generator set. Some vehicles may even have a generator compartment, provided by the vehicle manufacturer.

Plan the generator location based on the following:

- The generator set must be installed on a framework that is part of the recreational vehicle, as outlined in the paragraph entitled "Generator Support."
- The location must provide an access opening that is large enough to permit generator removal (unless the generator is to be removed from underneath the supporting framework).
- The location must provide easy access to frequently serviced components, such as filters, oil drains, spark plugs and other common maintenance parts.
- The location must provide sufficient room to allow minimum clearance of at least 1 inch between all sides and 1-1/2 inches on top of the generator. If sound insulation is to be used on compartment walls and ceiling, the minimum recommended applies to the space between the generator and such insulation.
- The location must provide adequate cooling and ventilating air flow for the generator without a great deal of work and expense.

GENERATOR SUPPORT

The generator must be securely attached to a metal framework that has been made part of the vehicle frame structure by bolting or welding. The metal framework on which the generator will rest and which will restrain the generator set should consist of at least two horizontal beams. These beams should consist of (a) 1-1/2 inch square, 11 gauge steel tubing OR (b) 1-1/2 inch, 11 gauge angle iron. A typical supporting frame with horizontal support tubing, is shown in Figure 14.

The generator can be installed so that it sits on top of the horizontal support tubing, if the vehicle design permits. Another method is to suspend the generator below the horizontal support tubing by means of suitable, structurally sound metal framework. The following general rules apply:

- Vehicle construction **MUST** be capable of supporting the weight of the generator.
- Whether the generator is mounted above the horizontal support tubing or suspended below the tubing, the supporting frame used must be structurally sound.
- If the generator cannot be bolted directly to the supporting frame or support tubing, consider using additional tubing, angle brackets or other supports to give the supporting frame sufficient strength.

Figure 14 — Typical Horizontal Support Frame

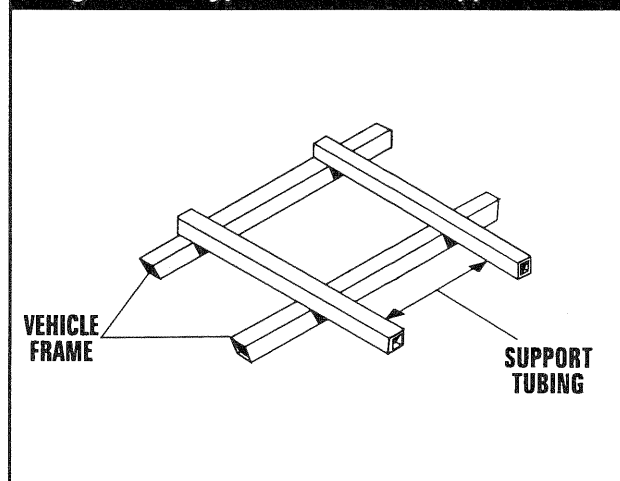

SUSPENDED MOUNTING

If you are going to suspend the generator below the horizontal support tubing, the suspension method you use with the vehicle frame members must have the following: (a) be able to support the weight of the generator; and (b) provide sufficient restraint for the generator. One typical suspended mounting system is shown in Figure 15. The location of a suspended mounting system must be carefully planned, keeping the following general rules in mind:

- Protect the generator against road splash and debris. Baffles or splash guards may be required to protect certain areas of the generator. To make sure the generator is adequately protected, road test the installation through mud, water and slush.

Figure 15 — Typical Suspended Mounting System

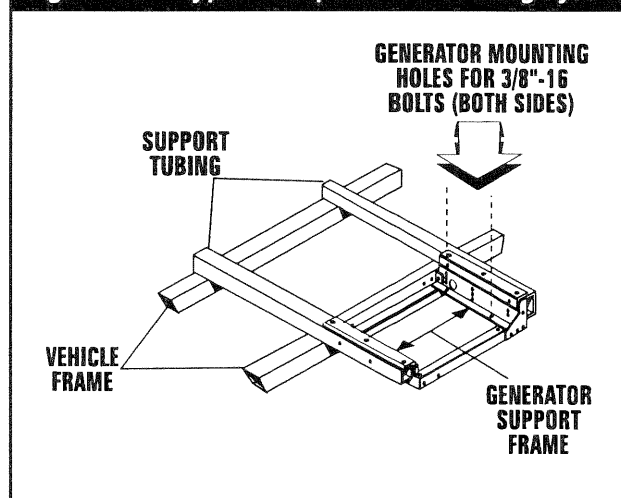

- The installer must make certain that selected location will permit adequate cooling and ventilating air flow to be supplied.

GENERATOR RESTRAINT

Use four 3/8"-16 hardened steel bolts (Grade 5) to fasten the generator to the supporting frame or the support tubing. These bolts must pass through (a) the generator mounting base, (b) the compartment floor, if a compartment is used, and (c) the supporting framework (Figure 16). All bolts must be long enough so that when tight, at least 3 threads are visible past the retaining lock nuts. Refer to "COMPARTMENT" section for location of generator mounting holes.

Figure 16 — Typical Generator Restraint

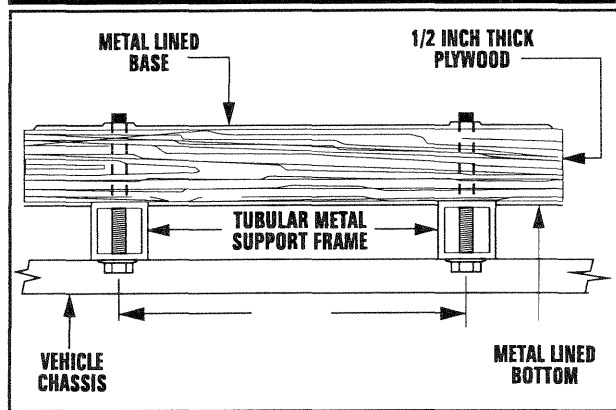

GENERATOR COMPARTMENTS

COMPARTMENTS

The generator set may or may not be installed inside a compartment that is constructed specifically for housing a generator. This section applies to generator compartments when they are installed. The following general rules apply to compartments:

- The generator compartment should be either constructed of, or lined with, 26 gauge galvanized steel.

IMPORTANT: ALUMINUM IS NOT AN ACCEPTABLE ALTERNATIVE TO GALVANIZED STEEL, DUE TO ALUMINUM'S LOW MELTING POINT.

- If the compartment is lined with galvanized steel, it may be constructed of any material. Generac recommends that the compartment be constructed of 1/2-inch thick plywood, with the floor made of a double thickness of plywood for added strength.
- All seams, splices and joints of the compartment walls (unless vapor tight by design) should be caulked.

IMPORTANT: CAULKING MUST BE DONE SO THAT THE CAULKING MATERIAL WILL STAY IN PLACE PERMANENTLY. PRESSING SUCH MATERIALS AS PUTTY TAPE ONTO JOINTS AND SEAMS WILL NOT MEET THAT REQUIREMENT. A HIGH QUALITY SILICONE RUBBER SEALANT IS RECOMMENDED.

- Holes and openings through the compartment walls for passage of electrical conduit, conductors, etc, into vehicle living area must be sealed vapor-tight with silicone rubber base sealant.
- If you use flexible metal conduit, seal the conduit at the end where it terminates inside the junction box. Flexible metal conduit is NOT vapor tight along its entire length.
- Seams and joints of the galvanized steel (whether used as a liner or the compartment itself) must be lapped and mechanically secured. Such seams may be manufactured, welded, bolted, riveted, or screwed. Manufactured lock seams are shown in Figure 17.

Figure 17 — Types of Lock Seams

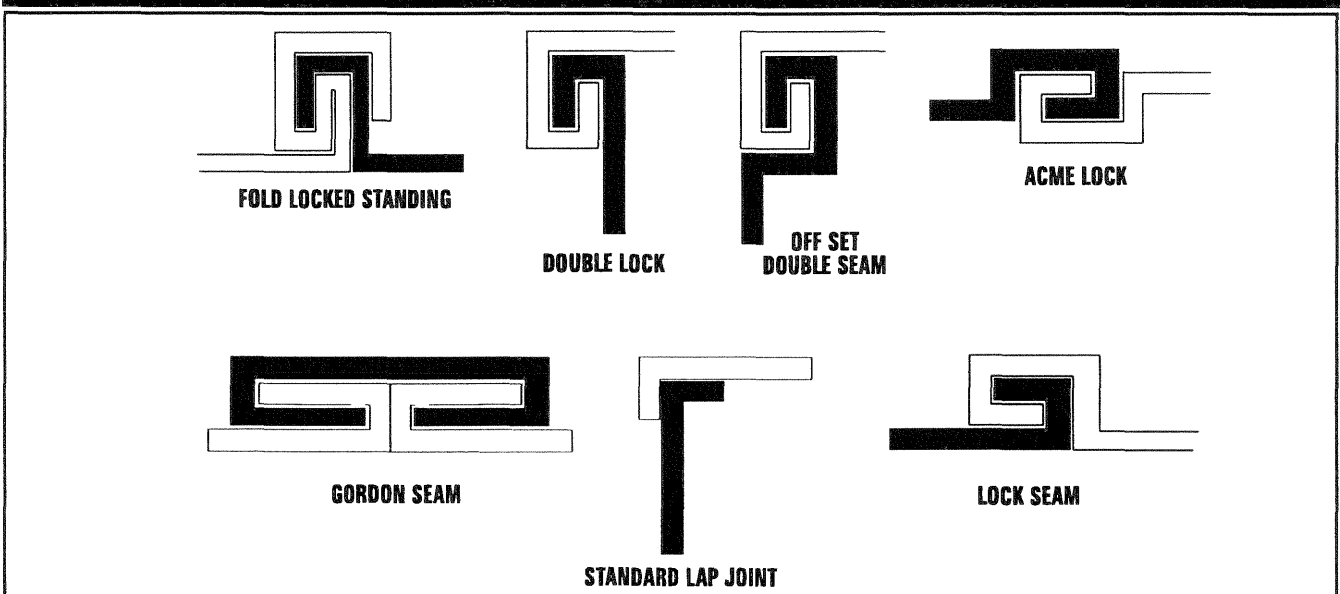

COMPARTMENT SIZE

Plan the compartment size carefully. Provide a minimum of at least 1 inch (2" recommended) of clearance between the generator and compartment walls and 1 inch (2" recommended) of clearance between the generator and the ceiling AFTER you have lined the compartment with metal, and AFTER you have installed sound insulation (Figure 18).

NOTE: Refer to the "Major Features and Dimensions" drawing in the back of this manual.

Figure 18 — Provide Clearance Around Generator

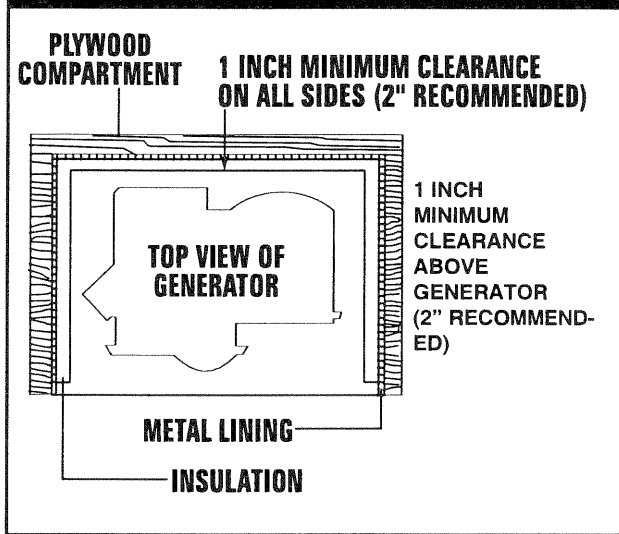

COMPARTMENT CONSTRUCTION

- The generator compartment should be constructed of 1/2 inch thick plywood. Make the compartment floor a double thickness of 1/2 inch plywood with the grain of the wood at cross section for added strength (Figure 19).

Figure 19 — Typical Compartment Construction

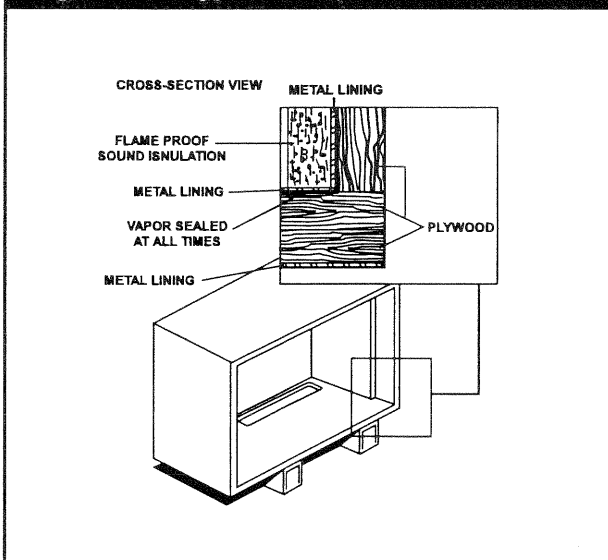

- Line the entire compartment interior with 26 gauge galvanized steel as described above.

- Line the exterior (underside) of the compartment floor with 26 gauge galvanized steel.
- Vapor seal all compartment seams and joints, to prevent poisonous, flammable or explosive vapors from entering the vehicle interior. Refer to the sealant information as noted previously.

NOTE: Silicone rubber base sealant is an acceptable caulking material. Pressing putty tape onto compartment joints and seams is NOT acceptable.

- After the compartment has been metal lined and vapor sealed, line the compartment interior walls and ceiling with an approved, non-flammable sound insulating material. See "Sound Insulating Materials."



DANGER: Do not install sound insulation or any absorbent material on the compartment floor interior. Such materials will become soaked with combustible or explosive vapors and liquids and will become a fire hazard.

- Openings in compartment walls for passage of electrical conduit, conductors, hoses, cables, etc., must be made vapor tight with suitable caulking material.
- Flexible conduit must be sealed internally at the end where it terminates inside a compartment's electrical junction box.

NOTE: The preceding is required because flexible conduit, due to its unique construction, is not vapor-tight along its entire length.



DANGER: Do not install any flammable material directly above or around the compartment. Heat, transferred through the compartment structure, may be sufficient to ignite, char or discolor seat cushions, fiberboard and other flammable materials. You may need to use approved non-flammable insulating materials in high temperature areas.

SOUND INSULATING MATERIALS

Once installers have determined that compartments are properly constructed and metal lined, they can add acoustical material. This may include additional sealant or insulating material, to reflect noise away from the vehicle interior.

Sound insulating materials should be of a non-flammable type. One excellent insulating material is a 1 inch thick fiberglass having a 2-pound density. When fiberglass is used, its coated side should face toward the compartment interior.

Using a combination of sound insulating materials can often reduce noise more effectively than a single material. For example, a sheet of lead or visco-elastic material, along with a layer of other acoustical material, is more effective than when a single material is used.

COMPARTMENT FLOOR CUTOUTS

You must provide openings in the generator compartment for the following items (Figure 20):

- Engine exhaust and cooling air outlets
- Generator cooling air inlet
- Four holes for passage of generator mounting bolts. See "Generator Restraint" on Page 19.



DANGER: Fuel lines and exhaust piping must not penetrate into vehicle living area.

ACOUSTICS

If excessive noise levels should become a problem, the installer may wish to consider the following:

- Using special sound insulating materials.
- Construction of a special noise abatement compartment.

IMPORTANT: ANY METHOD USED TO REDUCE NOISE MUST NOT ADVERSELY AFFECT THE FLOW OF COOLING AND VENTILATING AIR INTO OR OUT OF THE COMPARTMENT.

In addition to the effective use of sound insulating materials, construction of a special noise abatement compartment might be considered to reduce noise levels. Such a compartment might be constructed as follows (Figure 21):

- Use 5/8-inch thick or 3/4-inch thick plywood in the compartment.
- Construct the compartment floor of a double thickness of 5/8-inch or 3/4-inch plywood.
- Line the compartment interior walls and floor, as well as the underside of the floor, with 26-gauge galvanized steel.

- Vapor seal all compartment seams and joints.
- Over the galvanized steel lining, install a selected combination of acoustical materials as mentioned in "Sound Insulating Materials."

Figure 21 — Typical Noise Abatement Compartment

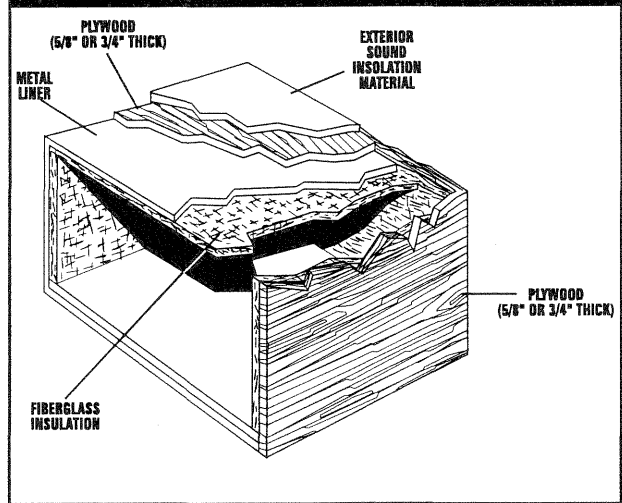

DANGER: Do not install any insulation or other absorbent materials on the interior or underside of the compartment floor.

- Seal all compartment door edges to prevent noise leakage around the door perimeter.
- Line the compartment door interior (except for air openings) with suitable, fire proof sound insulation (such as 1-inch thick fiberglass with a 2-pound density).

Figure 20 — Compartment Floor Cutout

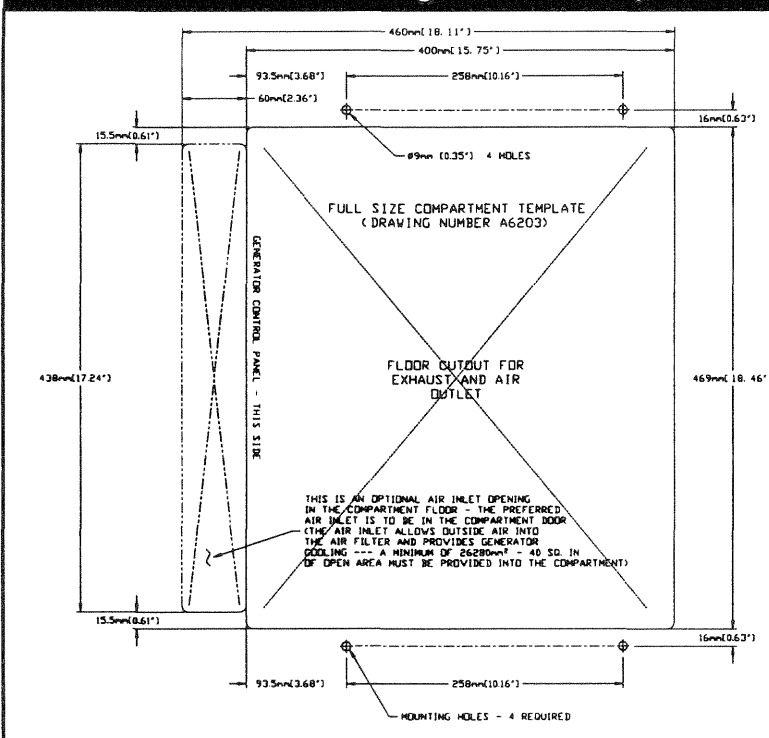

**FOR A FULL SIZE TEMPLATE,
CONTACT GENERAC RV SERVICE
DEPARTMENT AT:**

1-800-526-2871

DRAWING PART NO. A6203

COOLING AND VENTILATING AIR

It is absolutely essential that an adequate flow of air for cooling, ventilating and engine combustion be supplied to the generator set. Without sufficient air flow, the engine-generator quickly overheats. Such overheating can cause serious operating difficulties and may also cause fire and personal injury. The installer must make sure that sufficient air is available to the generator for cooling, ventilating and combustion. The installer must also provide for a path for exhausting the cooling air to the exterior of a compartment, if so equipped.



DANGER: Never use discharged cooling air for heating or permit such air to enter the vehicle interior. This air contains deadly carbon monoxide gas and other poisonous, flammable or explosive gases.

GENERATOR AIR FLOW

Engine operation drives cooling fans for the 2-stage cooling air system. A pressure fan draws cooling air into the top of generator and into the side of the control panel (Figure 22). This air flow cools the engine-generator and electronic components. The second part of cooling system, a suction fan, draws air that is heated from a hot engine into a collector pan at the base of the unit. This heated air (although cooler than exhaust muffler) is directed across the muffler to cool it. The heated air flow is then deflected out the bottom toward the ground.

Figure 22 — Air Flow Through Engine-Generator

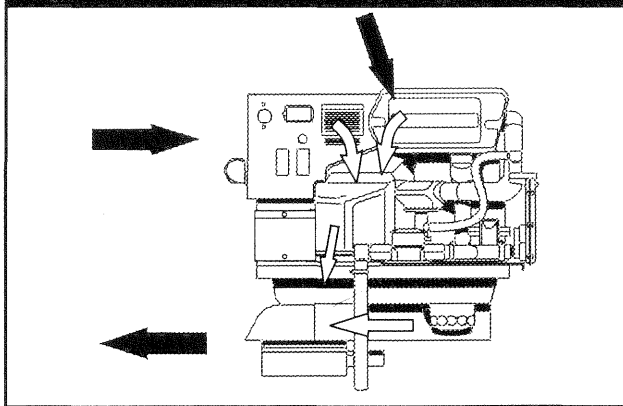

COOLING AIR INLET OPENINGS

Ideally, you should provide three air inlet openings, whether the generator is housed in a conventional compartment or not. Two of the openings should be 10 square inches and located as shown in Figure 23. The third opening should provide for a minimum of 40 square inches unrestricted and be located lower on the compartment door.

NOTE: Screening, louvers, or expanded metal that cover air openings restrict air flow that you must compensate for by making the actual air opening proportionately larger. See "Compensating for Restrictions."

For conventional compartment mounted units, the air inlet is generally provided in the compartment door.

Figure 23 — Air Inlet in Compartment Door

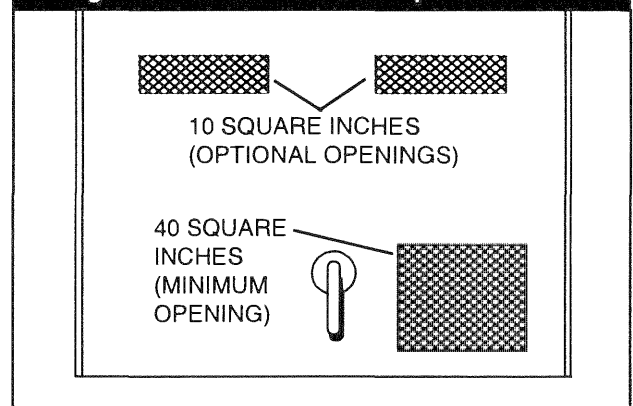

IMPORTANT: IF YOU PLAN TO INSTALL THE GENERATOR IN A COMPARTMENT, BE SURE TO LEAVE AT LEAST ONE INCH (2" RECOMMENDED) OF CLEARANCE BETWEEN THE GENERATOR AND COMPARTMENT WALLS AND CEILING. INCLUDE 26 GAUGE GALVANIZED STEEL LINING AND SOUND INSULATION WHEN YOU MEASURE FOR THIS 1 INCH (2" RECOMMENDED) CLEARANCE.

When the unit is installed on a suspended mounting system, one of several different methods of supplying air flow may be used as follows:

- Provide a door in the vehicle skirt having an air inlet opening (Figure 24).

Figure 24 — Suspended Mount Inlet Door

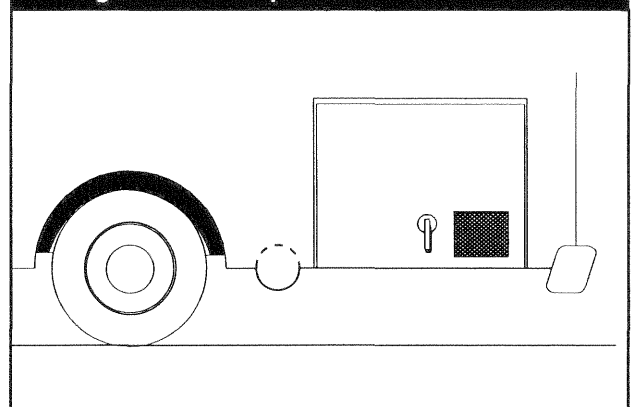

- Using ductwork (Figure 25 on Page 23). The installer must be sure air is available to the top of the generator since air inlets are located at the top.
- By providing an opening in the vehicle skirt and space above the generator for cooling air flow (Figure 26 on Page 23). Recommended clearance above the top of the generator is at least 2 inches.

Figure 25 — Air Inlet Using Ductwork

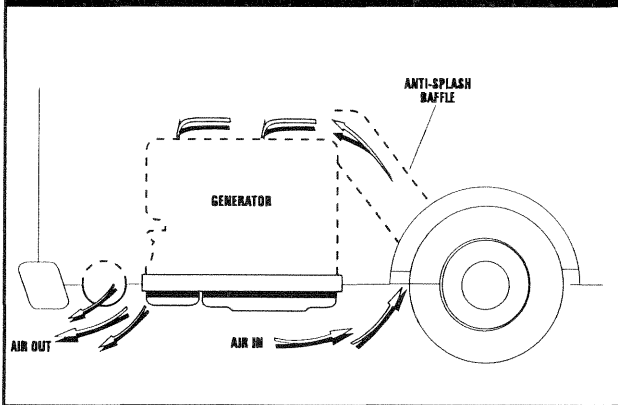
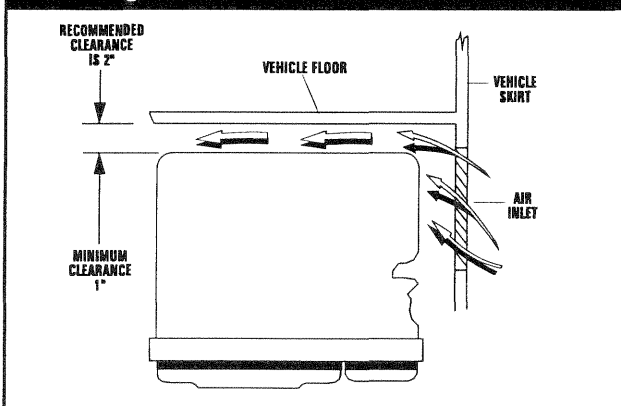

Figure 26 — Air Inlet in Vehicle Skirt



COMPENSATING FOR RESTRICTIONS

Such materials as screening, louvers, or expanded metal can restrict the free flow of air. Compensate for this restriction by making the actual air opening proportionately larger.

Some materials may offer only a 60 percent “free air inlet area.” Other more efficient materials may provide up to a 90 percent free air inlet area. The percentage of free air inlet opening is usually available from the material supplier or manufacturer.

TO DETERMINE THE ACTUAL AIR INLET OPENING SIZE REQUIRED, DIVIDE 40 SQUARE INCHES BY THE PERCENTAGE OF FREE AIR INLET AREA FOR THE MATERIAL YOU WILL USE.

For example: If you plan to use screening with an 80% free air inlet area, divide 40 by 0.8, which results in 50 square inches. Minimum actual size of air inlet opening in this case is 50 square inches. An opening that measures 4 inches wide by 12-1/2 inches long provides the required air flow ($4 \times 12.5 = 50$ square inches).

INVERTER LOCATION

The inverter should be located in a dry, well ventilated area in order for the inverter to work effectively. Approximately eight inches of space should be allowed at each end of the inverter for adequate ventilation.

The sensing harnesses supplied with the inverter have a maximum length of 12 feet. If the cables are longer than needed, coil the excess near the inverter unit. If a greater length is needed, contact Generac. **DO NOT ATTEMPT TO SHORTEN OR LENGTHEN THE SUPPLIED SENSING HARNESSSES.** The DC power wires may be cut to the required length. Allow enough length to make connection. Coil excess inside J-Box.

TESTING THE INSTALLATION

Generac recommends testing the installation to be sure adequate cooling air flow is available to the unit before placing the unit into service. If the unit shows signs of overheating, you will need to enlarge the air openings. Never place a unit into service until absolutely certain that cooling and ventilation is adequate.

IMPORTANT: YOU MUST TEST THE INSTALLATION ESPECIALLY IF YOU BRING IN AIR FROM BELOW THE GENERATOR SET.

GASOLINE FUEL SYSTEM

Installing a gasoline fuel system (Figure 27) for recreational vehicle generator sets must comply with applicable codes, standards and regulations. The entire fuel system must be completely free of leaks. There must be no possibility of gasoline vapors entering the vehicle interior.

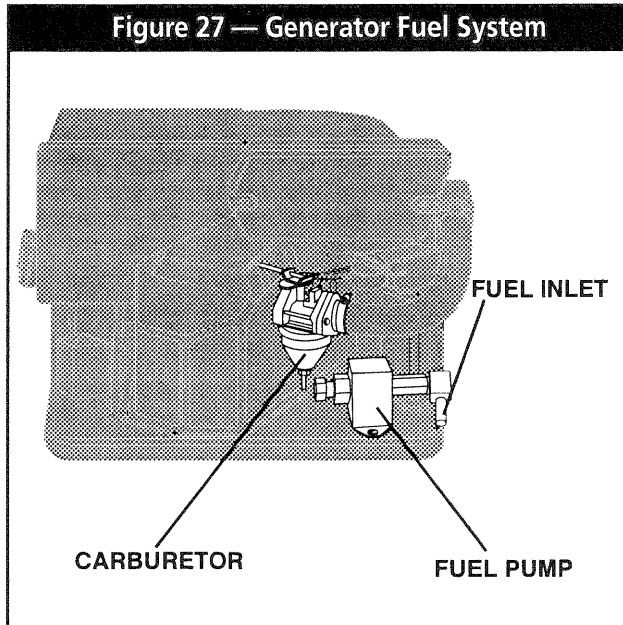

DANGER: Gasoline is highly flammable and its vapors are explosive. Comply with all codes, standards and regulations pertaining to gasoline fuel systems used in mobile generators. Properly install and maintain the fuel system and keep it entirely free of leaks. Gasoline vapors must not enter the vehicle interior.

Factory installed generator fuel system components include (a) fuel filter, (b) 12-volt DC electric pump, (c) engine carburetor, and (d) interconnecting lines and fittings. Connect a fuel supply line to the fuel filter inlet. Use a flexible length of approved fuel hose between the fuel filter inlet connection and rigid fuel lines.

FUEL TANK

Either the generator must share the vehicle engine's fuel tank, or you must install a separate fuel tank for the generator set. All fuel tanks installed on the vehicle must be constructed, installed, restrained so it complies with applicable codes, standards and regulations.

If the generator is to share the vehicle engine's tank, separate fuel pickup tubes are required for the engine and the generator. Generac recommends that you make the fuel pickup tube 2 to 3 inches shorter than the vehicle engine's pickup tube. This prevents the generator from depleting the entire fuel supply during prolonged generator operating periods.



CAUTION: Do NOT tee the generator fuel supply line into the vehicle engine fuel supply line. If this is done, the generator will be starved of fuel when both engines are operating at the same time. Also, while the vehicle engine is not running, generator operation may drain the vehicle engine supply line, making it difficult to start the vehicle engine.

GENERATOR FUEL SUPPLY LINE

■ RIGID FUEL LINES

Those lines used to supply fuel from a tank to the generator must comply with applicable codes, standards and regulations. The following generator rules apply to rigid fuel lines:

- Rigid lines should be of annealed, seamless, drawn aluminum or steel.
- Lines and fittings must comply with SAE J512F, "Standard Automotive Fittings", or with ANSI B126.26 (latest edition).
- Route the fuel line so that at least 2 inches of clearance is maintained between the line and any exhaust system parts.
- Do not attach electrical wiring to fuel lines. Route the wiring so it cannot come into contact with any fuel line.
- Route fuel lines so if they leak, fuel does not drip onto any electrical or exhaust system parts.
- Use non-ferrous metal straps without sharp edges to secure fuel lines.

■ FLEXIBLE FUEL LINE

Use an approved flexible length of fuel hose between the generator fuel inlet connection and rigid fuel lines. This prevents breaking of the line caused by vibration, shifting, settling or movement. The following rules apply:

- The flexible hose must comply with SAE J30B, "Standard for Fuel and Oil Hose". It must be approved for use with gasoline.
- The hose should be at least 6 inches longer than is needed to prevent the hose from rupturing if the generator shifts or settles.

PROPANE GAS FUEL SYSTEM



DANGER: LP (propane) gas is highly explosive. The gas is heavier than air and tends to settle in low areas, where even the slightest spark can ignite it and cause an explosion. Only competent, qualified persons should be allowed to install, test, adjust or service an LP gas fuel system. Install the optional fuel system in compliance with applicable codes, standards and regulations. After the installation, do nothing that might render the system in non-compliance with applicable codes and standards.

PARTS NOT INCLUDED IN FUEL SYSTEM

The propane fuel system does NOT include such items as (a) gas tank, (b) gas piping, (c) fittings, (d) valves, and (e) primary regulator, used to store the gaseous fuel and deliver it to the gaseous fuel solenoid (Figure 28).



DANGER: Use only approved components in the gas supply system. All components must be properly installed in accordance with applicable codes. Improper installation or use of unauthorized components may result in fire or an explosion. Follow approved methods to test the system for leaks. No leakage is permitted. Do not allow fuel vapors to enter the vehicle interior.

SOME IMPORTANT CONSIDERATIONS

When installing an LP gas system, consider seriously the following items:

- All fittings, lines, hoses and clamps must be tight and free of leaks. Apply a pipe sealant to threads when assembling threaded connections. This reduces the possibility of leakage.

Test the entire fuel system for leaks, using approved test methods.

- Optimum gas pressure at the inlet to the gaseous fuel solenoid valve and secondary regulator is 11 inches water column.
- The installer's fuel supply connection point is at the gaseous fuel solenoid valve. This is a 3/4 inch (female) connection. Provide a suitable 3/4 inch NPT (male) connector to attach to the fuel supply line.
- Use a length of approved flexible fuel hose between gaseous fuel solenoid valve and rigid gas piping. The flexible line should be at least six (6) inches longer than necessary.

VAPOR WITHDRAWAL

Liquid propane (LP) gas is stored in pressure tanks as a liquid. The gas systems used with these generators were designed only for "vapor withdrawal" type systems. Vapor withdrawal systems use the gas vapors that form above the liquid fuel in the tank. Do NOT attempt to use the kit along with any "liquid withdrawal" type system.

PRIMARY REGULATOR

Gas pressure delivered to the solenoid valve must be properly regulated by means of a primary gas regulator. Mount the primary regulator at the gas tank outlet or in the supply line from the gas tank. The following rules apply:

- For best results, the primary regulator supplies gaseous fuel to the secondary regulator at 11 inches water column. Do NOT exceed 14 inches water column.
- The installer must be sure the primary regulator is rated at sufficient gas flow to operate the generator plus all other gas appliances in the circuit.

Figure 28 — Diagram of LP Gas System

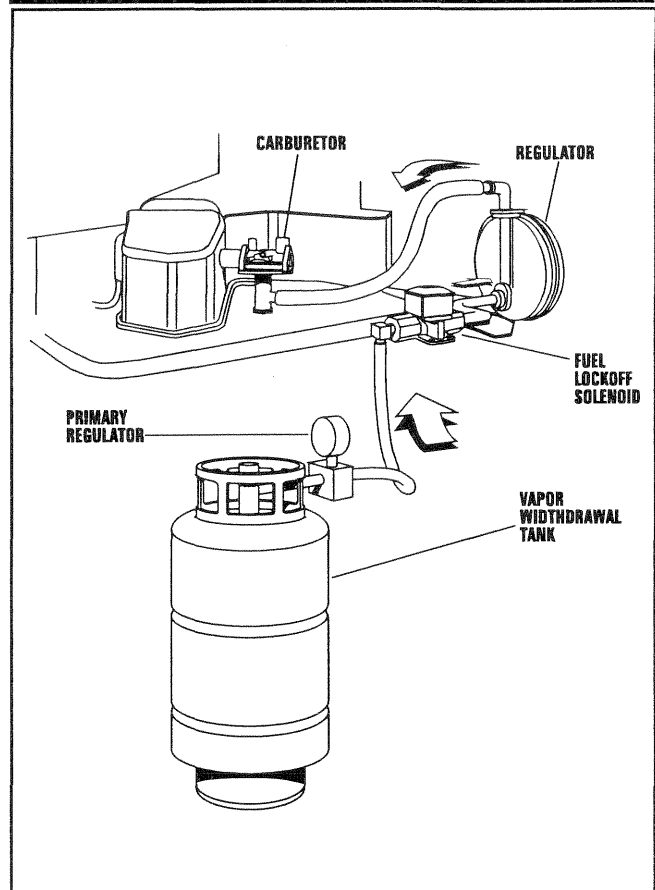

NOTE: Recommended MINIMUM gas flow rate for all air-cooled Impact-34 plus series generators is 67 cubic feet per hour.

IMPORTANT: IF AN EXISTING PRIMARY GAS REGULATOR DOES NOT HAVE A SUFFICIENT FLOW CAPACITY FOR THE GENERATOR AND OTHER GAS APPLIANCES IN THE CIRCUIT, (a) INSTALL A PRIMARY REGULATOR WITH ADEQUATE FLOW RATE, OR (b) INSTALL A SEPARATE REGULATOR RATED AT LEAST 67 CUBIC FEET PER HOUR. THE INLET SIDE OF ANY PRIMARY REGULATOR THAT SUPPLIES THE GENERATOR MUST CONNECT DIRECTLY TO GAS TANK PRESSURE. DO NOT TEE THE GENERATOR LINE INTO A GAS CIRCUIT FEEDING OTHER APPLIANCES.

GASEOUS CARBURETION

LP gas vapors should be supplied to the generator regulator inlet at about 11 inches water column (positive pressure). The engine piston draws air in during the intake stroke (Figure 29). This air passes through a carburetor venturi which creates a low pressure that is proportional to the quantity of air being pumped. The low pressure from the carburetor venturi acts on the regulator diaphragm, to pull the diaphragm toward the source of low pressure. A lever attached to the diaphragm opens a valve to permit gas flow through the carburetor.

The greater the air flow through the carburetor venturi, the lower the pressure at the venturi throat, the greater the diaphragm movement and the greater the movement of the regulator valve. The more the regulator valve opens, the greater the gas flow that is proportional to air flow through the carburetor.

The following facts about the secondary regulator must be emphasized:

- The regulator must be sensitive to venturi throat pressure changes throughout the operating range.
- The regulator must be properly adjusted so it will stop the flow of gas when the engine is not running (no air flow through the carburetor).
- The slightest air flow (and vacuum) in the venturi throat should move the regulator valve off its seat and permit gas to flow.

FUEL SUPPLY LINES

- Propane gas lines must be accessible, but protected against possible damage.
- Do NOT connect electrical wiring to any propane gas fuel line or run wiring alongside the lines.
- Route gas lines away from hot engine exhausts.
- Retain gas lines with metal clamps that do not have sharp edges.
- Install an approved length of flexible hose between the gaseous fuel solenoid valve and rigid fuel supply lines. The flexible line must be non-metallic, non-organic and non-conductive. It must be approved for use with LP gas.

EXCESS FLOW VALVE

Propane gas tanks should have an excess flow valve, according to NFPA 501C, Paragraph 3-4.4. This valve and the gas lines must be carefully sized so the valve will close when a fuel line is severed or broken. Consult the Natural-LP Gas Association for information and limitations of excess flow valves.

Manual shutoff valves on the supply tank and elsewhere in the system must be fully open when operating the generator. The excess flow valve functions properly only if all valves are fully open.

LEAKAGE TESTS

Do not place the generator into service until you have properly tested the gas system for leaks. To test the system, you need a separate source of 12 volts DC to open the gaseous fuel solenoid valve.

The leak test must comply fully with NFPA, Paragraph 318. All connections, hoses, valves, regulators, fitting, and other fuel system parts must be tested under gas or air pressure of not less than 90 psi (620kPa), while using soap and water or equivalent solution to check for leaks. Other approved methods of testing for leaks may be used, if appropriate. **DO NOT USE ANY FLAME TO TEST FOR LEAKS.**

 **DANGER:** Gaseous fuel lines between the tank and the secondary regulator are under a positive pressure (about 11 inches water column). Gas pressure at the outlet side of the secondary regulator, however, is a negative pressure (about 1-inch water column) and can draw flame inside a line or fitting and cause an explosion.

Figure 29 — Propane Gas Carburetion Diagram



EXHAUST SYSTEM

The generator exhaust system must be safely and properly installed. Only approved mufflers and other exhaust system parts must be used. A properly installed exhaust system must be vapor tight, quiet and completely safe.

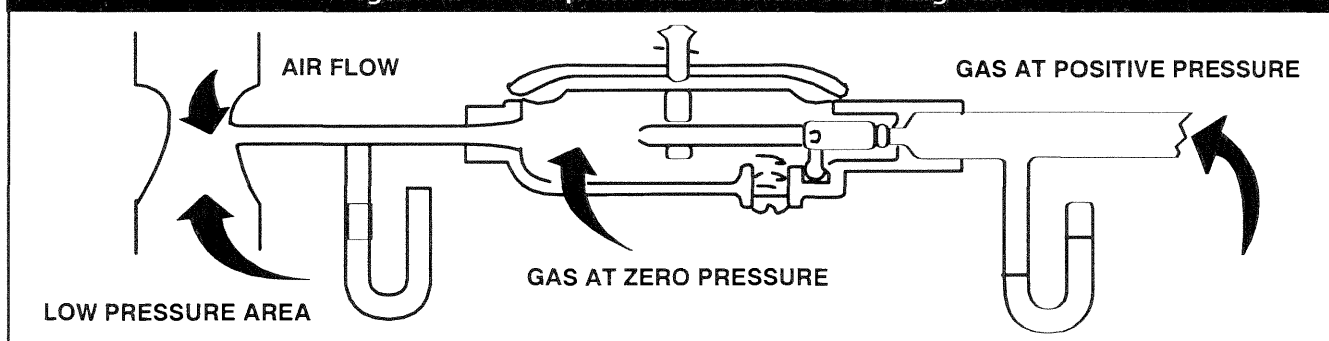

CAUTION: Never tee the generator engine exhaust pipe into the vehicle engine exhaust piping. This causes excessive back pressure on the generator engine. Also, water from one engine can damage the other engine.



DANGER: The generator engine gives off deadly carbon monoxide gas through its exhaust system. This dangerous gas, if breathed in sufficient concentrations, can cause unconsciousness or even death. Symptoms of carbon monoxide poisoning are (a) inability to think coherently, (b) vomiting, (c) twitching muscles, (d) throbbing in temples, (e) dizziness, (f) headache, (g) weakness and sleepiness. If any of these symptoms are experienced, move into fresh air immediately. If symptoms persist, get medical attention. Do not operate the generator until its exhaust system has been inspected and repaired.

MUFFLERS AND SPARK ARRESTORS

Exhaust mufflers and spark arrestors that Generac supplies meet code and standard requirements, and are approved by the U.S. Forest Service. Use only mufflers and parts approved by Generac. Any person(s) installing an unapproved muffler, or an unapproved exhaust system part, or modifying an exhaust system in any way that might cause a hazard, is liable for any damage, injury or warranty expense that might be caused by such unapproved installation or modification.

Failure to provide and maintain a spark arrestor may be in violation of the law. If this generator is used on any forest covered, brush covered, or grass covered unimproved land, you must provide a spark arrestor. The vehicle owner or operator must maintain this device in good condition. In the State of California, the preceding is required by law (Section 4442 of the California Public Resources Code). Other states may have similar laws. Federal laws apply on federal lands.

TYPE OF EXHAUST SYSTEM

The Impact-36 plus and Impact-34 plus generators have a configuration for a bottom out exhaust system and is equipped with such an exhaust muffler (Figure 30).

EXHAUST SYSTEM SAFETY

- Maintain a clearance of at least 3 inches (76mm) between exhaust system parts and any combustible material (such as wood, felt, cotton, organic fibers or other like material). If you cannot maintain the 3-inch clearance, locate, insulate or shield the exhaust part(s) so that the temperature of any combustible material is not raised more than 117°F (65°C) above the ambient air temperature.
- Extend the exhaust system at least one inch (25mm) past the outer edge of the vehicle. Do not terminate the exhaust system under the vehicle.
- Terminate the exhaust tailpipe such that exhaust gases will not be drawn back into the generator compartment and recirculated.
- If there is any possibility of the tailpipe or muffler being damaged, protect these damage prone areas by means of a protective device (such as a "skid bar").
- Install the generator exhaust system according to safe automotive practices.
- Use enough exhaust system hangers to prevent any part of the system from being dislocated.
- Use exhaust system parts recommended by Generac. Using unapproved exhaust mufflers and exhaust system parts is the responsibility of the person(s) installing such unauthorized parts.
- Do not terminate the exhaust system under any opening, window or vent which can be opened or is not permanently sealed from the vehicle interior.
- Exhaust piping must be large enough to prevent excessive back pressure on the generator engine.
- Never tee the generator engine exhaust pipe into the vehicle engine exhaust piping. This causes excessive back pressure on the generator engine. Also, water from one engine can damage the other engine.
- Plan exhaust system installation carefully. Comply with all applicable codes, standards and regulations.

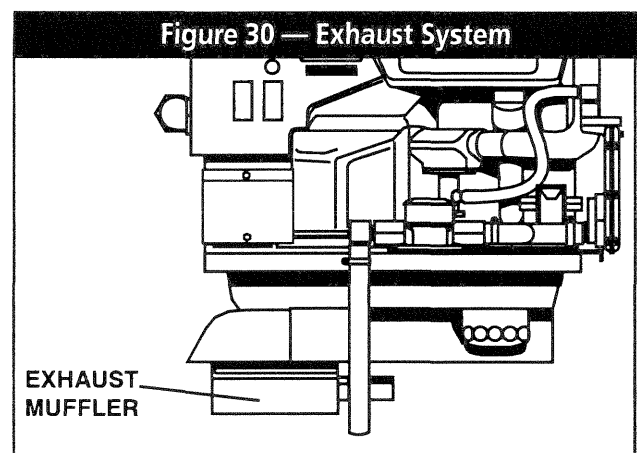

ELECTRICAL CONNECTIONS

The following general rules apply to electrical connections in a recreational vehicle:

- Qualified electricians who are familiar with applicable codes, standards and regulations should install electrical wiring.
- The wiring should comply with codes, standards and regulations. The National Electric Code (NFPA 70), as well as state and local codes, apply.
- Switches and circuit breakers should be of a type approved for use in recreational vehicles and must be mounted and installed to prevent damage from road shock.
- Wiring must be of adequate size, with approved insulative qualities, and properly supported.
- Conduit and wire openings into generator compartment (if used) must be vapor-sealed, to prevent entry of flammable, explosive or poisonous gases into the vehicle.

WIRING

- Wiring should be of stranded copper to reduce chance that vibration may cause breakage.
- Wire gauge size of wires should be large enough to handle at least 115% of the installed generator's rated maximum current.
- If neutral conductors are used, they must be the same size as other leg wires.
- Route power supply conductors from generator DC output leads +DC (Red) and -DC (Blue), the return (Black) and the ground (Green) wire through approved flexible conduit, through the compartment floor and to the terminal block located in the DC junction box on the inverter. Refer to ANSI/RVIA standard EGS-1-1993 for conduit selection.
- If flexible metal conduit is used between the generator and the compartment junction box, the conduit end that terminates at the compartment junction box must be vapor-sealed. Flexible metal conduit is NOT vapor tight along its entire length.
- From the AC output junction box on the inverter, route the three wires T1 (Black), T2 (White), and the Green ground wire through approved flexible conduit to either (a) double-pole, double-throw transfer switch, or (b) approved isolation receptacle. Connecting to a transfer switch or isolation receptacle must prevent vehicle electrical circuits from being connected to two different power supplies at the same time (such as generator and dockside power).
- Conductors must be rated 221°F (105°C) or must be of a larger conductor size.

GENERATOR AC CONNECTION SYSTEM

The Impact plus AC generator output is provided by the remote located inverter module. 120V AC is provided from the terminal block located inside one of the J boxes on the inverter unit (Figure 31). The unit is provided with a ground which is connected to the generator and should be connected to the chassis of the recreational vehicle.

Figure 31 — Inverter J Box for AC Output

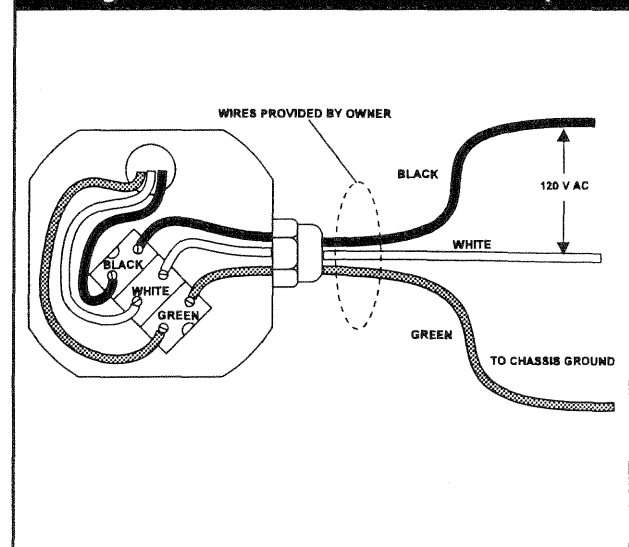

Circuit breaker protection is provided on the generator and protects the unit against overload. Do not apply loads which exceed the rated wattage capacity of the generator. Add the watts or amperes of all lighting, appliance, tool and motor loads that the generator will operate at one time. This total should be less than the units rated wattage/ampere capacity.

ISOLATING DIFFERENT POWER SOURCES

Conductors from the junction box must terminate in a double pole, double throw transfer switch (Figure 33 on Page 30). An alternate method for isolating different power sources is by using an isolating receptacle (Figure 34 on Page 30). Whichever method you use, you must be certain that both power sources are NOT connected at the same time.

POWER SUPPLY CORD

The power supply cord must comply with all applicable codes, standards and regulations. It must be large enough to handle the full amperage to which it will be subjected.

Figure 32 — Generator to Inverter Connection

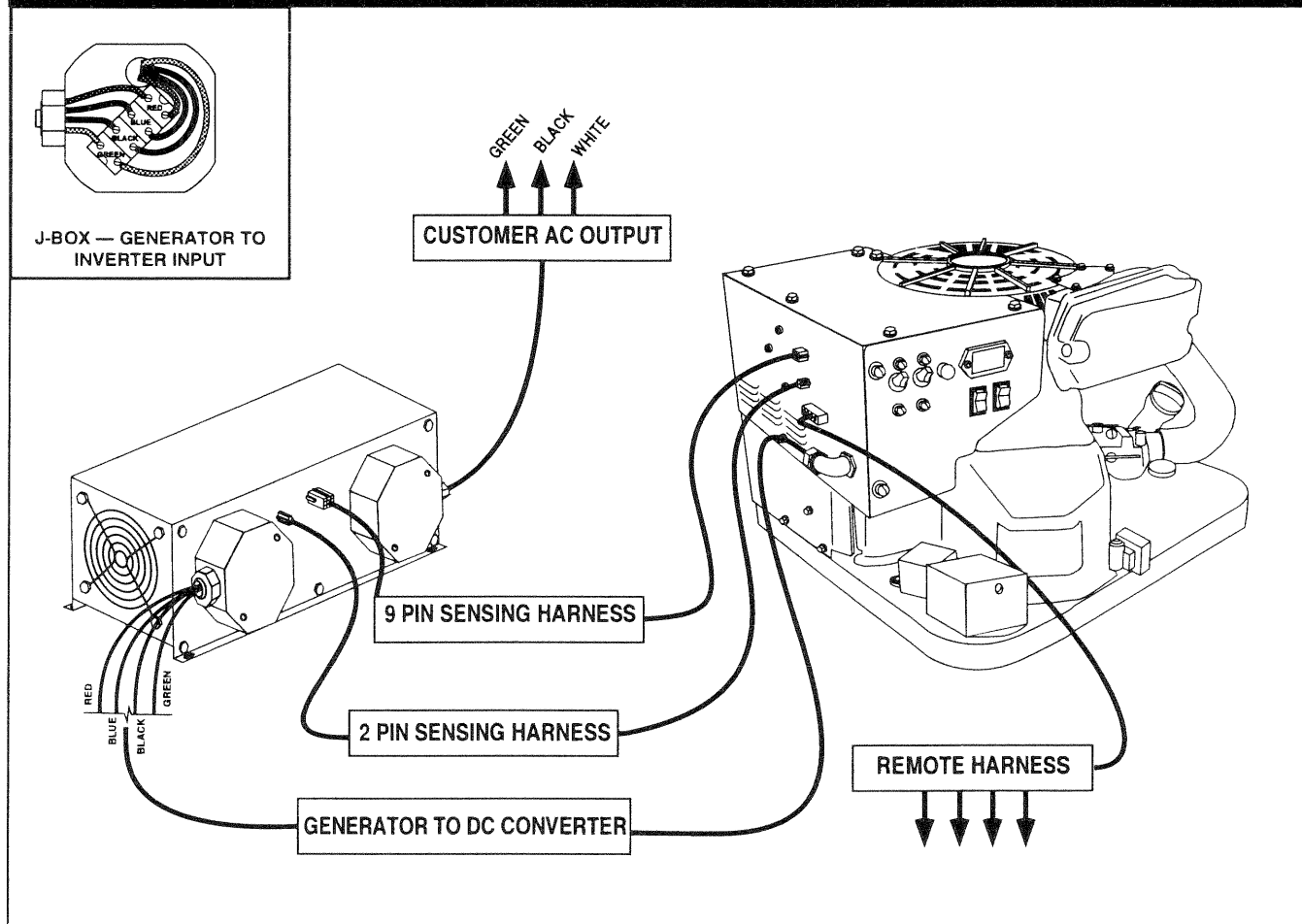

GROUND FAULT CIRCUIT INTERRUPTERS

The National Electric Code (NFPA 70, 551-7) requires that you install ground fault circuit interrupters (GFCIs) on all external and some internal electrical receptacles. Contact your manufacturer or dealer for recommendations.

SENSING HARNESSES

Sensing harnesses have been provided with the generator to connect to the inverter (Figure 32). They are 12 feet long each, however, they are available in 24 feet lengths: Part #'s A6429A and A6430A. The four (4) DC power wires (Red, Blue Black, and Green) may be cut to the desired length to meet the installation (see Figure 32).



CAUTION: DO NOT in any way cut or shorten the two sensing harnesses. If the harnesses are too long, simply tie the excess up neatly with standard cable ties.

Figure 33 — Transfer Switch Isolation Method

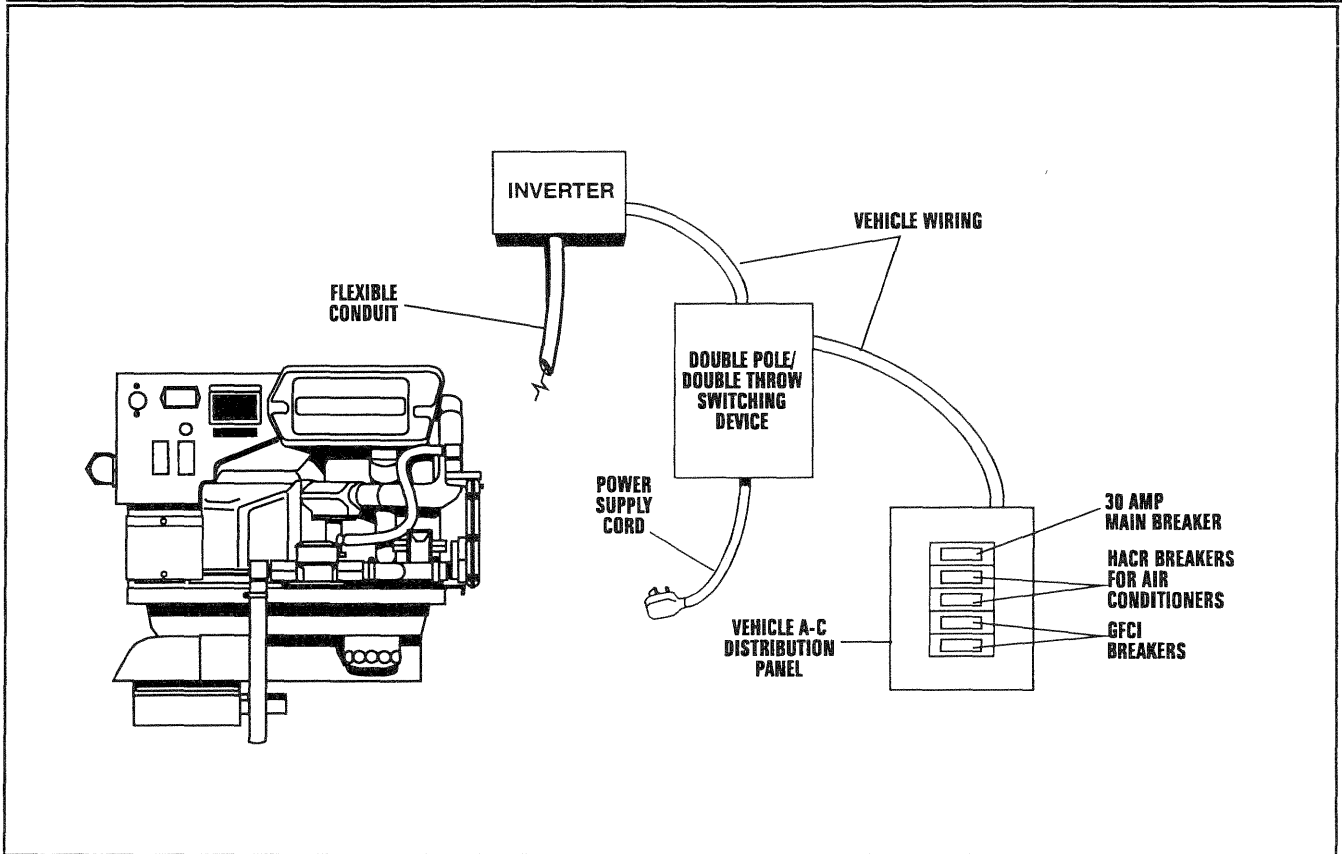
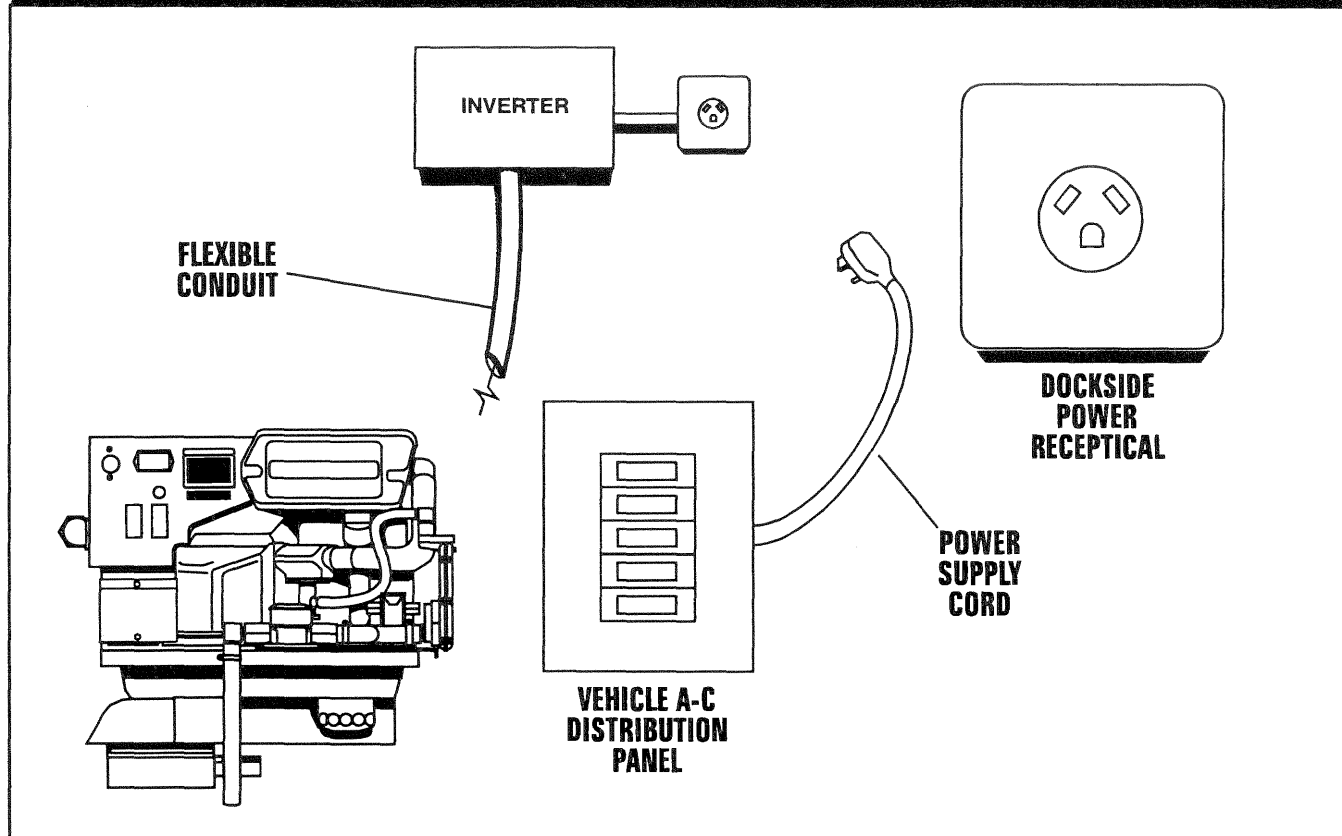

Figure 34 — Installation with Isolation Receptacle



BATTERY INSTALLATION

RECOMMENDED BATTERY

Install a battery that meets the following requirements:

- Battery must be a 12 volt, automotive type storage battery.
- For prevailing ambient temperatures above 32°F (0°C), use a battery rated 70 amp-hours and capable of delivering 400 cold cranking amperes.
- For prevailing ambient temperatures below 32°F (0°C), use a battery rated 95 amp-hours and capable of delivering 450 cold cranking amperes.

IMPORTANT: IF THE BATTERY IS TO BE USED TO POWER OTHER VEHICLE ACCESSORIES, AS WELL AS START THE GENERATOR, YOU MAY NEED A BATTERY WITH A LARGER CAPACITY.

BATTERY CABLES

Using battery cables that are too long or too small in diameter may cause a drop in voltage which causes starting problems. For best cold weather starting, the voltage drop between battery terminals and the generator connection point should not exceed 0.12 volts per 100 amperes of cranking current.

Select battery cables based on (a) cable length, and (b) prevailing ambient temperatures. Generally, the longer the cable and the colder the weather, the larger the cable size must be as shown in the chart below.

CABLE LENGTH in Feet (meters)	CABLE SIZE
0 to 10 (0 to 3)	2*
11 to 15 (3.4 to 4.5)	0
16 to 20 (4.5 to 6)	000

*For warm weather, use No. 2 cable up to 20 feet.

BATTERY CABLE CONNECTIONS

1. Connect the battery cable from the battery post or terminal indicated by a POSITIVE, POS or (+) to the large lug on the starter contactor as indicated in Figure 35.
2. Connect the battery cable from the battery post indicated by a NEGATIVE, NEG or (—) to the frame ground connection (Figure 35).

NOTE: If the generator compartment is grounded to the vehicle chassis, you need not connect a NEGATIVE battery cable to the frame ground on the generator base. Connect the negative cable to the frame ground of the chassis.

3. Connect cables so the connections are clean and tight.

BATTERY COMPARTMENT

Install the generator battery in its own, vented compartment. Place the battery compartment away from any source of heat, sparks or flame.

Provide ventilation openings in the battery compartment. The minimum size of openings should be 2 square inches at the top of the compartment. Mount the battery on a strong, rigid supporting structure, where leaks and spills of battery fluid will not cause damage.

Figure 35 — Connecting Battery Cables

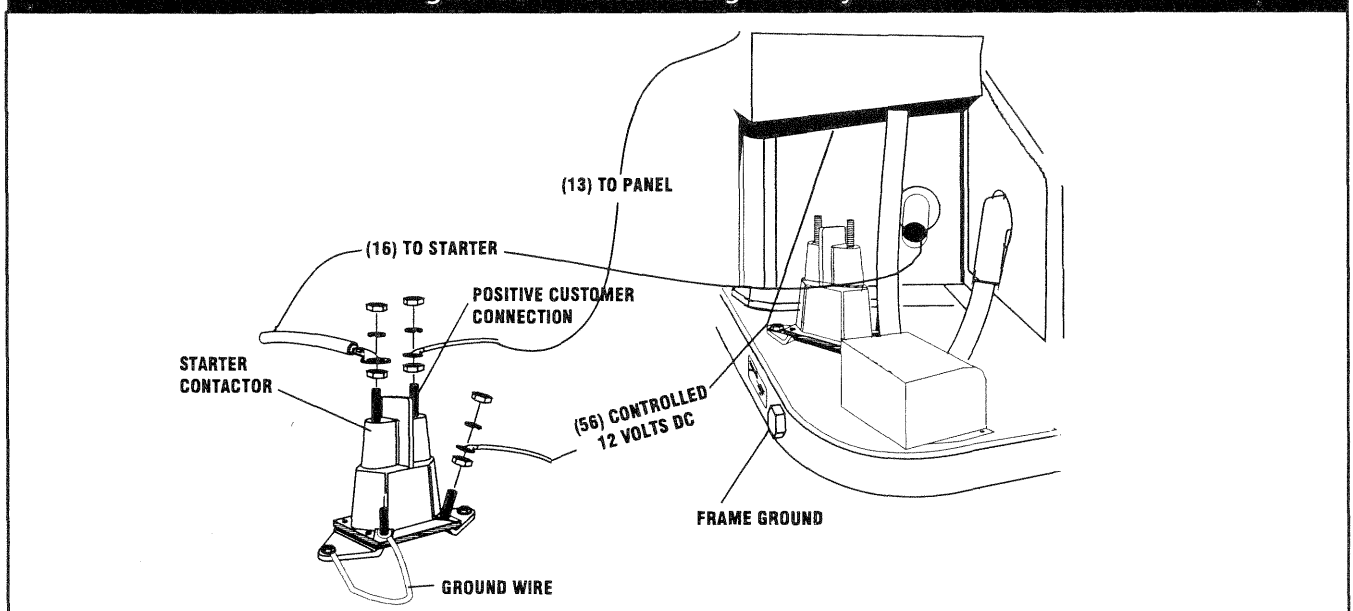

OPTIONAL ACCESSORIES

A plug-in receptacle (Figure 36) is provided on the generator set, near the DC power wires. Use this receptacle to connect an optional remote-mounted start/stop panel to the generator. Installation of such a panel will permit you to start and stop the generator engine from any convenient location inside the vehicle.

Figure 36 — Remote Panel Plug-In Receptacle

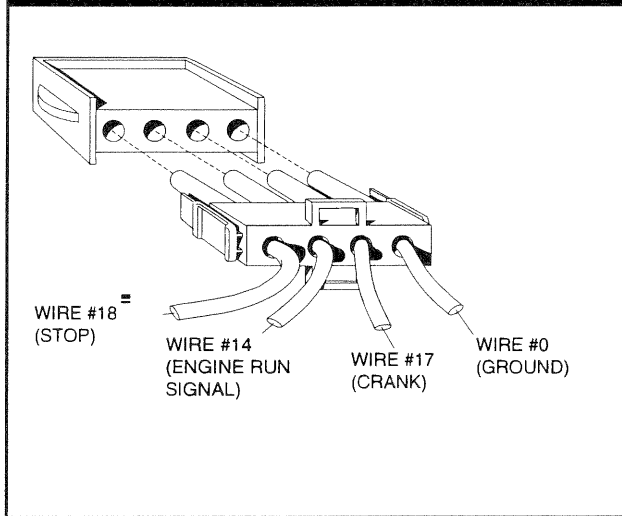

REMOTE PANEL MODELS

Model 9042: This remote panel (Figure 37) mounts a rocker type start/stop switch and a "Generator Run" advisory lamp. The lamp will turn on to indicate the engine is running.

Figure 37 — Model 9042 Remote Panel

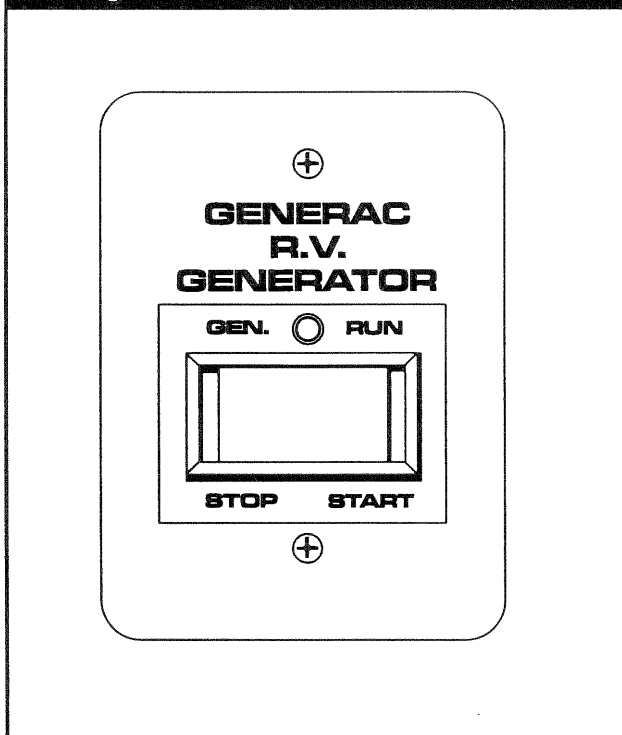

Model 9043: This panel mounts a rocker type switch, a "Generator Run" lamp and an hourmeter (Figure 38). Use the hourmeter in conjunction with the periodic maintenance schedule for your generator.

Figure 38 — Model 9043 Remote Panel

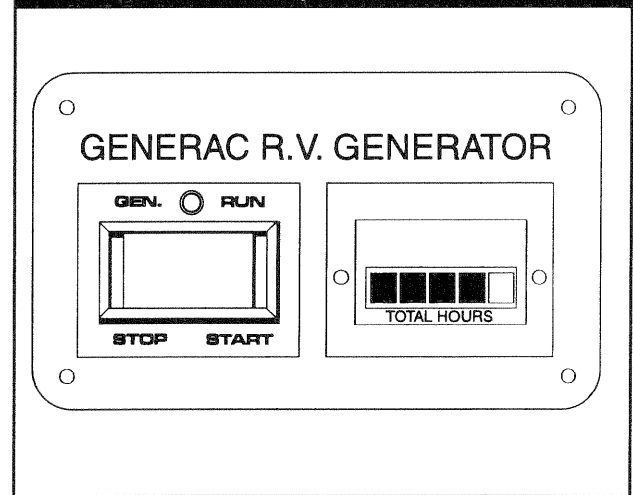

REMOTE PANEL CABLES

Interconnection cables are available from Generac for connecting the optional remote panels to the generator receptacle.

- To order a 10-foot long, 4-wire cable, specify Model 9045.
- To order a 30-foot long, 4-wire cable, specify Model 9046.

POST INSTALLATION TESTS

The air cooled Impact-36 plus generator set was factory tested and adjusted using gasoline as fuel. The air cooled Impact-34 plus generator set was factory tested and adjusted using LP gas as fuel. You should not be required to adjust the unit any further except under special circumstances.



WARNING: Do not make any unnecessary adjustments. Factory settings are correct for most applications. When making adjustments, however, be careful to avoid overspeeding the engine.

BEFORE INITIAL START UP

Before starting, complete the following:

1. Check engine crankcase oil level and, if necessary, fill to dipstick FULL mark with the recommended oil. Do not fill above FULL mark.
2. Check the fuel supply. Gas fuel lines must have been properly purged and leak tested in accordance with applicable fuel codes. All fuel shutoff valves in the fuel supply lines must be open.



DANGER: If an LP (propane) gas fuel system has been installed, it must have been properly tested for leaks before operating the system in compliance with ANSI A119.2/NFPA 501C. No leakage is permitted. You must be sure no gaseous fuel vapors enter the vehicle interior.

INITIAL START

When absolutely certain that the unit has been properly installed and prepared for use, start the engine as follows:

1. Turn off all electrical loads. Do this by setting the generator main circuit breaker to its "OFF" or "OPEN" position.
2. Refer to the Owner's Manual shipped with unit for cranking and starting instructions. The engine may require more cranking for initial starting since the fuel lines have to be primed (Use of the Primer Switch on gasoline units will shorten this time).

3. Let the engine warm up for about five minutes to allow internal temperatures to stabilize.
4. Carefully inspect the engine-generator for fuel, oil and exhaust system leaks. Before proceeding to the next step, correct any leakage immediately.
5. When all tests and adjustments at no-load are completed, apply electrical loads and check for proper operation under load. See "Testing Under Load". Run the unit at least 30 minutes with loads applied.
6. Turn off all electrical loads by setting the generator main circuit breaker to "OFF" or "OPEN."
7. Let the unit run at no-load for a few minutes to stabilize internal engine-generator temperatures. Then, shut down the engine.

IMPORTANT: THE GENERATOR SET WAS THOROUGHLY TESTED AND ADJUSTED AT THE FACTORY BEFORE SHIPPING. NO ADDITIONAL ADJUSTMENT SHOULD BE NECESSARY. ONLY QUALIFIED SERVICE TECHNICIANS WHO HAVE BEEN TRAINED SHOULD PERFORM ADJUSTMENTS OUTLINED IN THIS MANUAL.

TESTING UNDER LOAD

Apply electrical loads equal to about 75-100% of the unit's rated wattage/ampere capacity.

Let the unit run at least 30 minutes with load applied. During this part of the test, check that the unit is not running excessively hot and that adequate cooling air flow is available. You must not allow the unit to overheat during prolonged operation.

NOTE: The generator engine is equipped with a high temperature switch. The switch has normally-open (N.O.) contacts. When the temperature is too high, switch contacts close, and engine shuts down automatically.

IMPORTANT: GENERAC RECOMMENDS THAT YOU TEST THE GENERATOR FOR ADEQUATE COOLING.

INSTALLATION CHECK LIST

LOCATION AND SUPPORT

- 1. The generator is properly located.
- 2. The generator is properly supported.
- 3. The generator is properly restrained.
- 4. The inverter is mounted securely.

COMPARTMENT

- 1. Compartment construction is proper.
- 2. Holes/openings are vapor-sealed.
- 3. Compartment size is correct.
- 4. Compartment is vapor-sealed.
- 5. Sound insulation is O.K.
- 6. Floor cutouts properly completed.

COOLING and VENTILATING AIR

- 1. Air flow is adequate.
- 2. Air inlet opening is correct.
- 3. Compensate for restrictions
- 4. Installation has been tested
- 5. Inverter has adequate ventilation.

FUEL SYSTEM

- 1. Fuel tank complies with code.
- 2. Fuel system properly installed.
- 3. Fuel system checked for leaks.

EXHAUST SYSTEM

- 1. Complies with code requirements.
- 2. Properly and safely installed.

ELECTRICAL CONNECTIONS

- 1. Comply with code requirements.
- 2. Inverter properly installed.
- 3. Wiring meets all standards.
- 4. All connections are correct.
- 5. Conduit properly installed and sealed.
- 6. Generator properly bonded to vehicle.

BATTERY INSTALLATION

- 1. Recommended battery is installed.
- 2. Recommended cables are installed.
- 3. Cables are clean and tight.
- 4. Cables are properly connected.
- 5. Proper ventilation is provided.

POST INSTALLATION TESTS

- 1. All tests properly completed.

OPTIONS AND ACCESSORIES

Check that remote start/stop panels (if used) are properly installed.

If an hourmeter kit is installed, check that job was done properly.

If any other options and accessories are installed, check that they were installed properly.

DATE OF INSTALLATION

NAME OF INSTALLER

SIGNATURE OF INSTALLER

MAJOR FEATURES AND DIMENSIONS

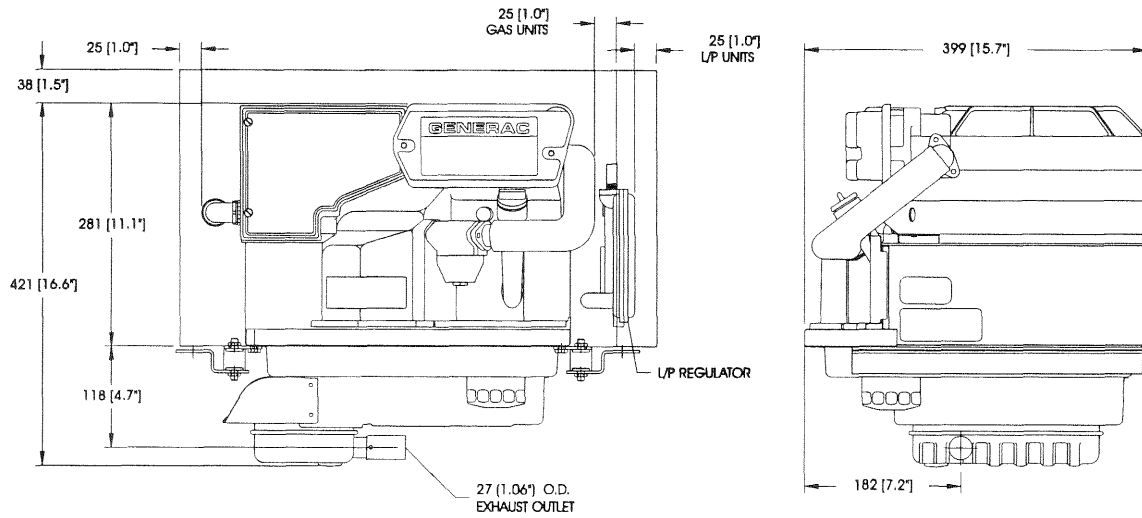
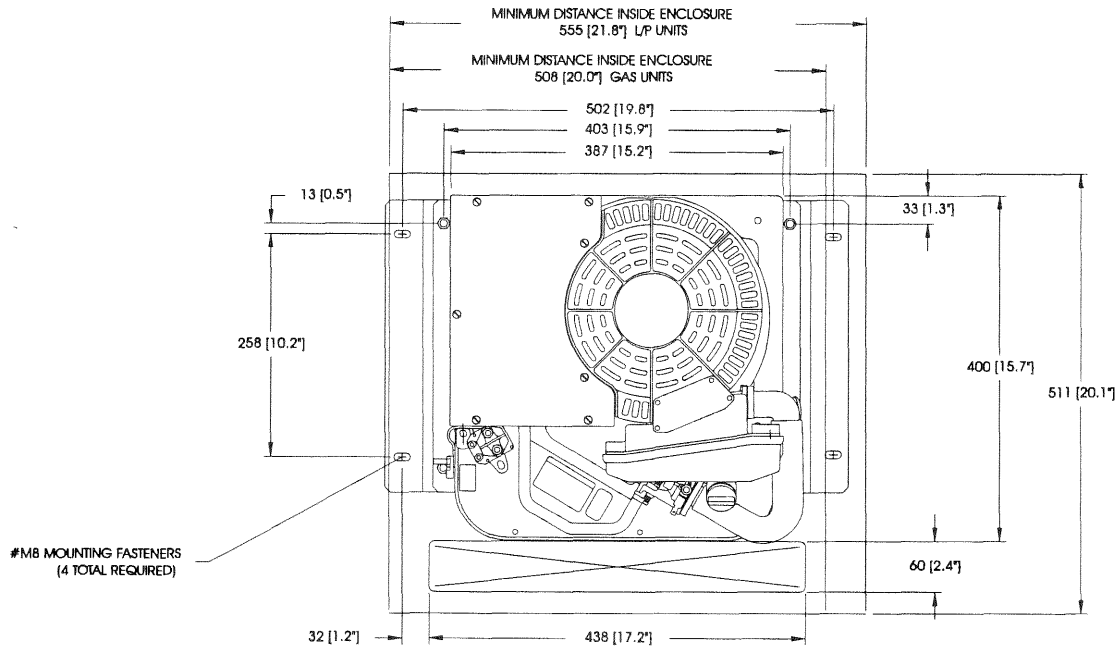

MAJOR FEATURES AND DIMENSIONS (CONTINUED)

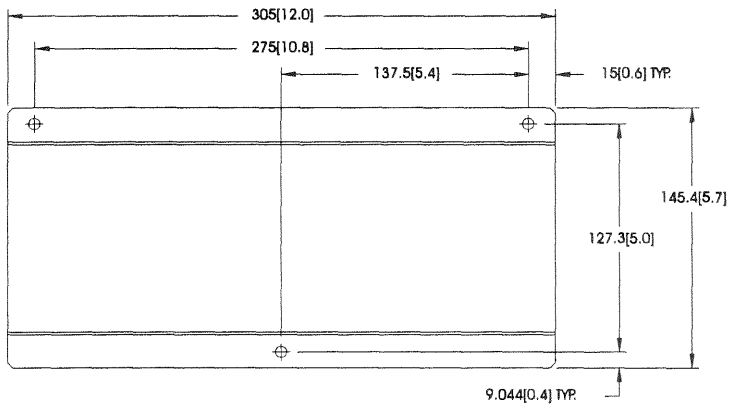

MOUNTING HOLE DETAIL

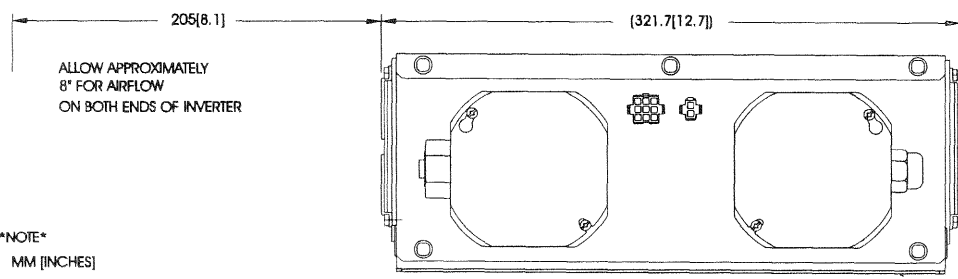
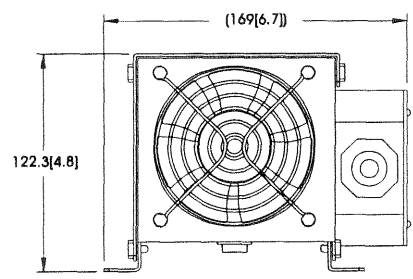
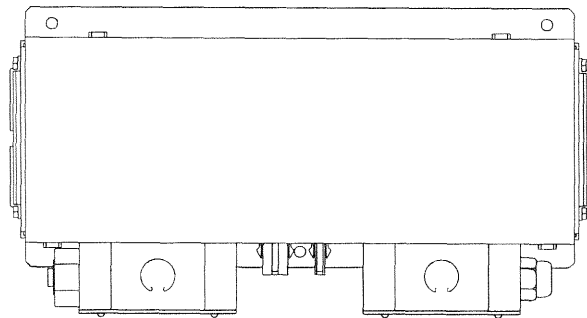

ALLOW APPROXIMATELY
8" FOR AIRFLOW
ON BOTH ENDS OF INVERTER

NOTE
DIMENSIONS IN MM [INCHES]

TROUBLESHOOTING

PROBLEM	POSSIBLE CAUSES	REMEDY
Engine won't crank.	<ol style="list-style-type: none"> 1. Fuse is blown. 2. Loose corroded or defective battery cables. 3. Defective engine Start/Stop switch. 4. Defective starter contactor. 5. Defective starter motor. 6. Low or defective Battery 	<ol style="list-style-type: none"> 1. Replace 15 amp fuse. 2. Tighten, clean or replace as necessary. 3. Replace Start/Stop switch. 4. Replace contactor. 5. Replace starter motor. 6. Charge or replace battery.
Engine cranks but won't start, low full load power.	<ol style="list-style-type: none"> 1. Out of fuel. 2. Fuel pump is defective (Gasoline), OR, fuel solenoid is defective (LP). 3. Open Wire #14 from Eng. Control Bd. 4. Engine is flooded. 5. Spark plug defective. 6. Loose spark plug boot. 	<ol style="list-style-type: none"> 1. Replenish fuel. 2. Replace defective fuel pump or fuel solenoid. 3. Reconnect wire. 4. Wait 5-10 min. before trying. 5. Clean, regap or replace plug. 6. Press boot on securely.
Engine starts hard, runs rough.	<ol style="list-style-type: none"> 1. Air cleaner plugged or damaged. 2. Defective spark plug. 	<ol style="list-style-type: none"> 1. Clean or replace as needed. 2. Clean, regap or replace plug.
Engine starts, shuts down when Start/Stop switch is released.	<ol style="list-style-type: none"> 1. Engine oil is low. 2. Engine is overheated. 3. Defective Low Oil Pressure System 4. Defective Control Board 5. Defective Computer Control Board. 	<ol style="list-style-type: none"> 1. Check oil; add as needed. 2. Check adequate ventilation. 3. Have serviced/replaced. 4. Have board serviced/replaced. 5. Have board serviced/replaced.
Start/Stop switch at Stop, engine continues to run.	<ol style="list-style-type: none"> 1. Defective Start/Stop switch 2. Open/disconnected wire #18 between Start/Stop switch and Control 3. Open/disconnected wire #0 between Start/Stop switch & Control Bd. 4. Defective Control Board 	<ol style="list-style-type: none"> 1. Replace switch. 2. Reconnect or close wire. 3. Reconnect or close wire. 4. Replace board.
No output from generator.	<ol style="list-style-type: none"> 1. Check circuit breaker. 2. Check vehicle circuit breaker & fuses. 3. Transfer sw. set to NORMAL position. 4. Generator internal failure. 5. Inverter defective. 	<ol style="list-style-type: none"> 1. Reset to ON or CLOSED. 2. Reset and replace if necessary. 3. Set to GENERATOR position. 4. Take generator to an Authorized Generac facility. 5. Take generator to an Authorized Generac facility.

ELECTRICAL DATA

Drawing No. A6412-B (Sheet 1 of 2)

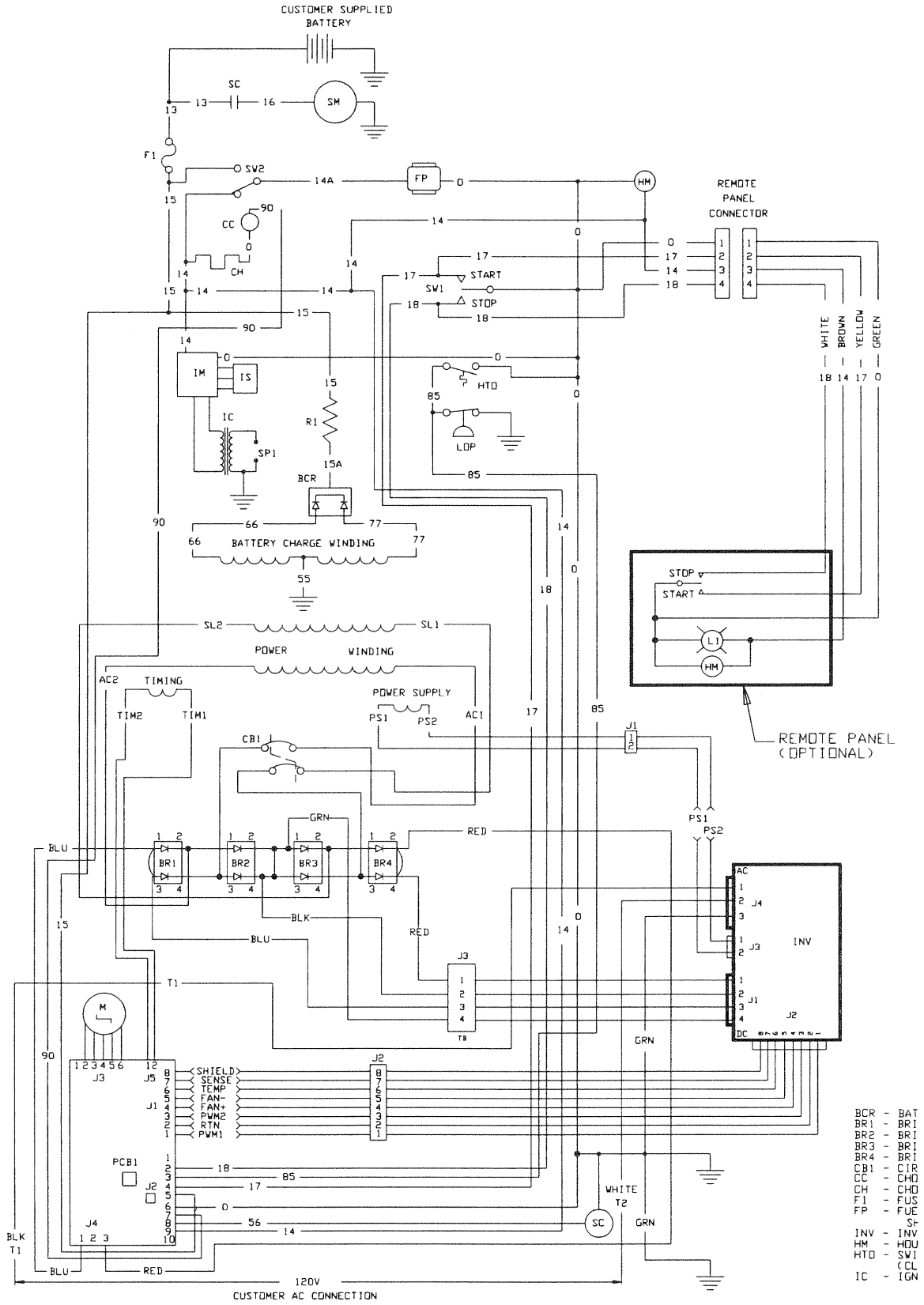

- BCR - BAT
- BR1 - BR1
- BR2 - BR1
- BR3 - BR1
- BR4 - BR1
- CB1 - CIR
- CH - CHD
- F1 - FUS
- FP - FUE
- HM - HDU
- HTD - SW1
- IC - CCL
- IGN

ELECTRICAL DATA

Drawing No. A6412-B (Sheet 2 of 2)

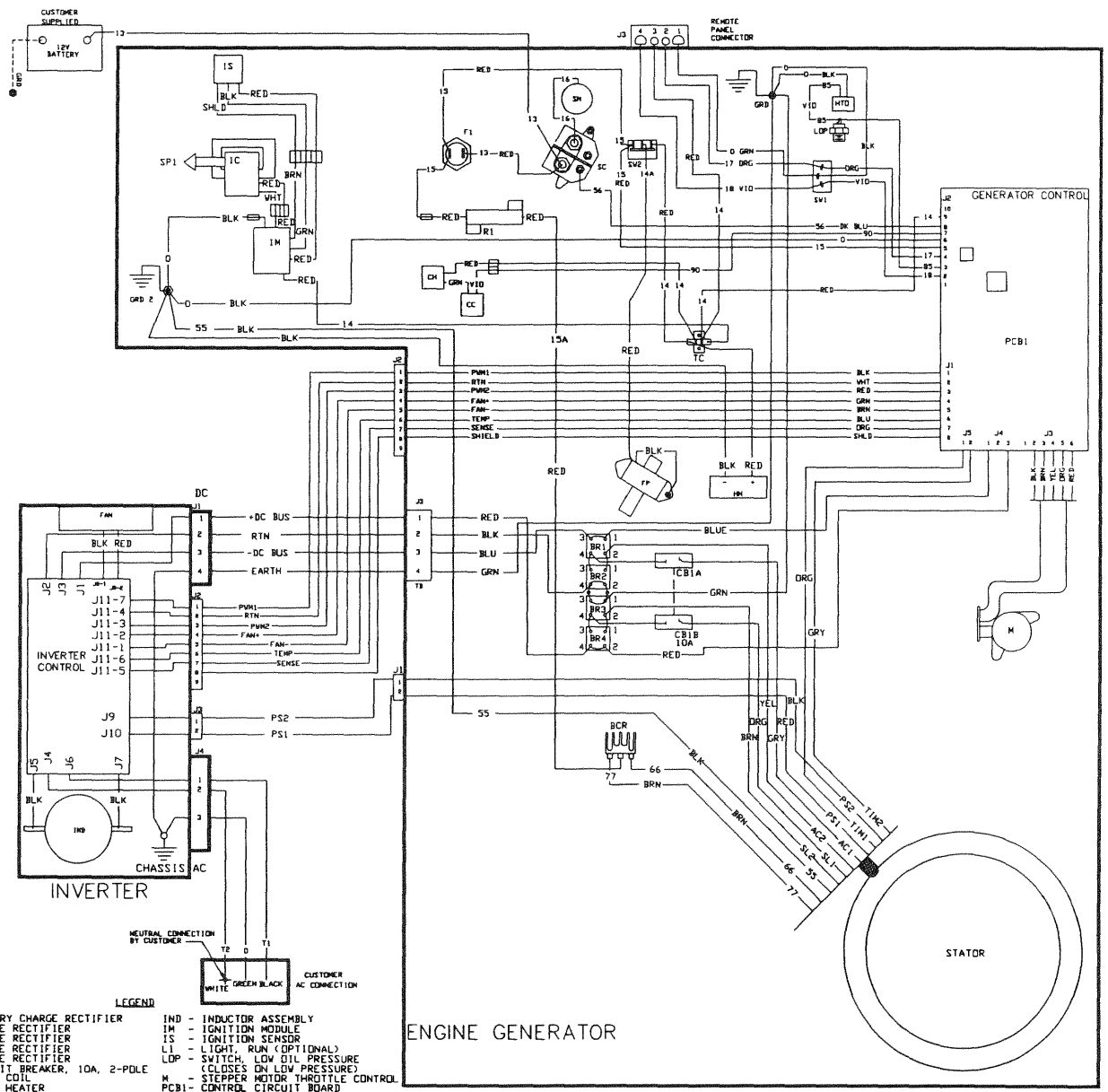

- LEGEND**
- BCR - BATTERY CHARGE RECTIFIER
 - BR1 - BRIDGE RECTIFIER
 - BR2 - BRIDGE RECTIFIER
 - BR3 - BRIDGE RECTIFIER
 - BR4 - BRIDGE RECTIFIER
 - CB1 - CIRCUIT BREAKER, 10A, 2-POLE
 - CC - CHOKE COIL
 - CH - CHOKE HEATER
 - F1 - FUSE
 - FP - FUEL PUMP ON GASOLINE SHUT-OFF VALVE DN L/P
 - INV - INVERTER BOX
 - NM - HOUR METER
 - HTD - SWITCH, HIGH TEMPERATURE OIL (CLOSES ON HIGH TEMPERATURE)
 - IC - IGNITION COIL
 - IND - INDUCTOR ASSEMBLY
 - IM - IGNITION MODULE
 - IS - IGNITION SENSOR
 - LI - LIGHT, RUN (OPTIONAL)
 - L1 - SWITCH, LOW OIL PRESSURE (CLOSES ON LOW PRESSURE)
 - M - STEPPER MOTOR THROTTLE CONTROL
 - N - CONTROL CIRCUIT BOARD
 - PCB1 - CONTROL CIRCUIT BOARD
 - SC - STARTER CONTACTOR
 - SM - STARTER MOTOR
 - R1 - 1 OHM, 50 WATTS
 - SW1 - SWITCH, START/STOP
 - SW2 - SWITCH, FUEL PUMP PRIME
 - SP1 - SPARK PLUG
 - TC - LUG, BARREL
 - TB - TERMINAL BLOCK

EXPLODED VIEW — GASOLINE GENERATOR

Drawing No. A6414-E

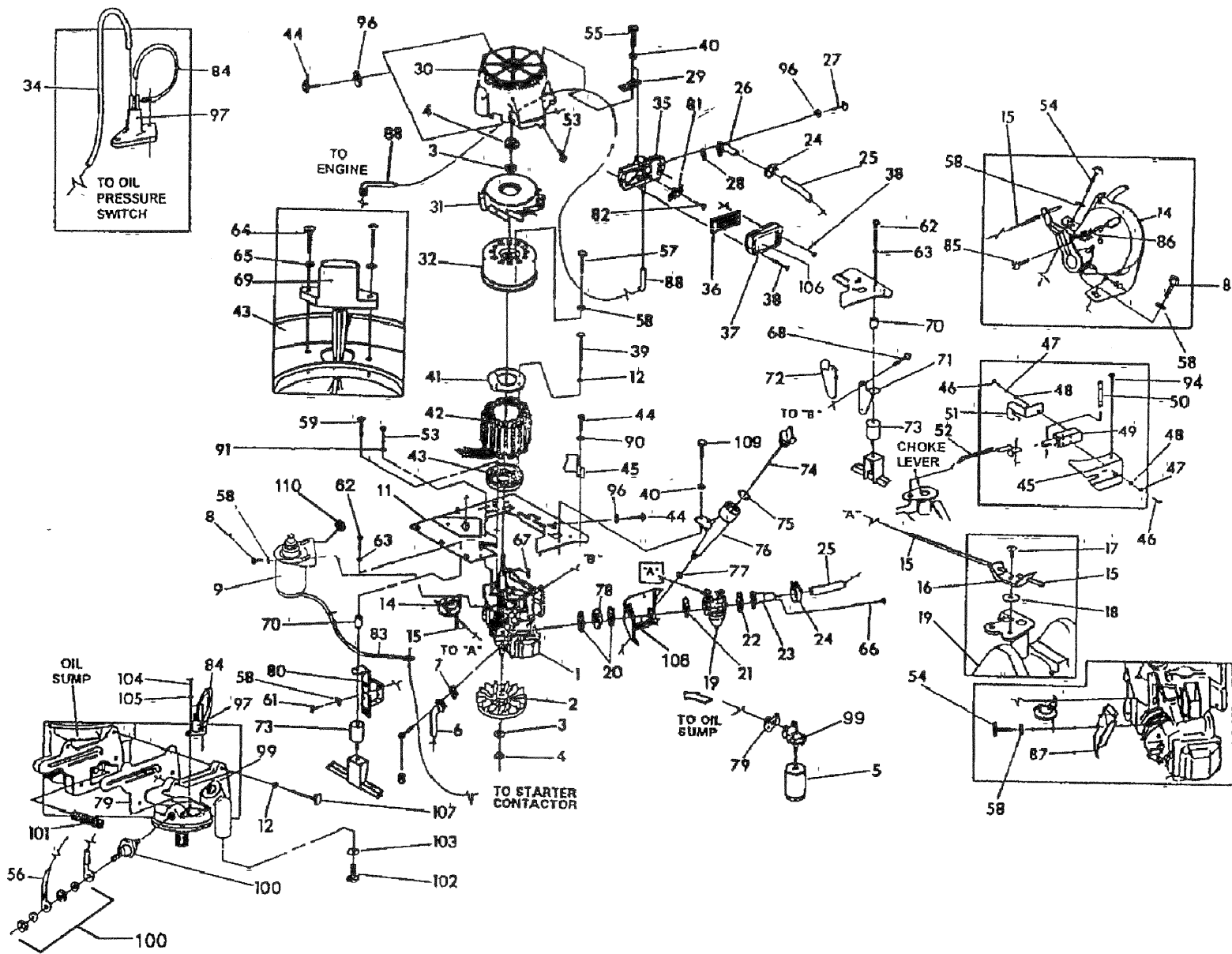

REPAIR PARTS — GASOLINE GENERATOR

Drawing No. A6414-E

ITEM	PART NO.	QTY.	DESCRIPTION	ITEM	PART NO.	QTY.	DESCRIPTION
1	A2467	1	ENGINE, LONG BLOCK GN220	55	52618	5	M5 - 0.8 X 12 MM CAPSCREW
2	94583	1	FLYWHEEL, FAN	56	005-91297	1	TEMP. SWITCH WIRE
3	83312	2	WASHER, CONICAL	57	42907	3	HEX HD. CAPSCR., M8-1.25 x 16MM
4	81810	2	HEX NUT, M16-1.5	58	22129	10	LOCK WASHER-M8
5	70185	1	FILTER, OIL	59	74906	4	M6-1 x 20MM TAPTITE
6	86730	1	TUBE, EXHAUST OUTLET	61	39253	3	HEX HD. CAPSCR., M8-1.25 x 20MM
7	89476	1	GASKET, EXHAUST	62	22511	3	HEX HD. CAPSCR., 3/8"-16 x 1.25"
8	40976	4	SOCKET HD. CAPSCR., M8-1.25 x 20MM	63	22237	3	LOCK WASHER-3/8"
9	99948	1	STARTER, EATON/GENERAC	64	55822	2	PHMS, M4- .7 x 8MM
11	86705	1	PLATE, DIVIDER	65	22264	2	LOCK WASHER-M4
12	22097	8	LOCK WASHER, 1/4"-M6	66	89050	2	PHILLIPS PAN HD. MACH. SCR.-M6-1 x 90MM
14	92059	1	STEPPER MOTOR SPEED CONTROL	67	82774	1	WOODRUFF KEY-4MM x 19MM
15	86706	1	ROD, THROTTLE CONTROL	68	59637	4	TAPTITE 3/8"-16 x .75" LONG
16	89477	1	CLIP, ADJUSTMENT	69	86697	1	ASSEMBLY IGNITION SENSOR
17	89478	1	SNAP, RETAINING	70	86704	3	SPACER, ENGINE MOUNT
18	90192	1	WASHER, CARBURETOR	71	86701	1	BRACKET, ENGINE MOUNT FRONT
19	90881A	1	ASSEMBLY, CARBURETOR	72	86702	1	BRACKET, ENGINE MOUNT REAR
20	90051	2	GASKET, CARBURETOR/ SPACER/HEAD	73	38353	3	RUBBER MOUNTS
21	78631	1	GASKET, CARBURETOR/SKIRT	74	89263	1	ASSEMBLY, OIL FILL CAP
22	96459	1	GASKET, CARBURETOR/INLET ADAPTOR	75	90071	1	O-RING, 1.062" I.D.
23	86709	1	ADAPTOR, CARBURETOR INLET	76	94637	1	OIL FILL TUBE
24	35586	2	HOSE CLAMP-BAND #20	77	90072	1	O-RING .562" I.D.
25	86710	1	HOSE, CARBURETOR INLET	78	86708	1	CARBURETOR SPACER
26	87993	1	ELBOW, AIR CLEANER OUTLET	79	87478	1	GASKET, OIL FILTER ADAPTOR
27	49815	2	HEX HD. CAPSCR., M5-.8 x 16MM	80	96627	1	BRACKET, STARTER SIDE ENGINE MNT.
28	90536	1	GASKET, AIR CLEANER OUTLET	81	90613	1	COVER, BREATHER CANAL
29	90021	1	BRACKET, AIR CLEANER SUPPORT	82	59635	1	#8 x .37" LG PLASTITE SCREW
30	94665	1	HOUSING, FAN-UPPER	83	002-91297	1	STARTER WIRE
31	93859	1	FAN, GENERATOR	84	004-91297	1	TEMP SWITCH GROUND WIRE
32	A5892	1	ASSEMBLY, MAGNET HOUSING	85	59636	1	PLASTITE SCREW, #4 x .37"
34	003-91297	1	TEMP SWITCH WIRE	86	88905	1	EXTENSION SPRING
35	86673	1	BASE, AIR BOX	87	92800	1	WRAPPER, ENGINE TOP
36	78601	1	ELEMENT, AIR FILTER	88	89062	1	HOSE, BREATHER
37	86674	1	COVER, AIR BOX	90	23762	2	WASHER, EXTERNAL SHAKEPROOF-#10
38	78609	2	BOLT, AIR CLEANER COVER	91	22447	3	WASHER, INTERNAL SHAKEPROOF, .25"
39	66449C	4	HEX HD. CAPSCR., M6-1 x 80MM	94	23484P	1	SNAP BUSHING
40	49226	4	LOCK WASHER, M5	96	23897	6	#10-M5 FLAT WASHER
41	80934	1	RETAINING RING, STATOR	97	94090	1	SWITCH-THERMAL, OIL TEMP.
42	A6420	1	ASSEMBLY STATOR	99	86675A	1	ADAPTOR, OIL FILTER
43	86692	1	ADAPTOR, STATOR	100	77667	1	SWITCH, OIL PRESSURE
44	74908	3	TAPTITE, M5-0.8 x 10MM	101	86714	1	SCREEN, OIL PICK-UP
45	86735	1	COVER, CHOKE MOUNT	102	52617	1	DRAIN PLUG, M12 -1.75 x 20MM
46	47488	4	SCREW, #4-40 x 3/16"	103	C2908	1	GASKET, OIL DRAIN PLUG
47	22159	4	LOCK WASHER-#4	104	C1085	2	PPHMS, M3- 0.5 x 8MM
48	31879	4	FLAT WASHER-#4	105	43182	2	LOCK WASHER, M3
49	91306	1	SOLENOID, CHOKE	106	C2334	1	AIR CLEANER DECAL
50	36544	1	PIN, COTTER 3/32" x 1/2	107	97962	4	SHCS, M6-1.0 x 25 LG
51	89473	1	ASSEMBLY, BI-METAL & HEATER	108	86726	1	SKIRT, BAFFLE
52	86736	1	LINKAGE, CHOKE CONTROL	109	56893	1	CRIMPTITE, #10-24 x 1/2"
53	45756	3	M6 -1 x 10MM TAPTITE	110	A9257	1	SHIM, STARTER
54	83512	1	TAPTITE M8-1.25 x 15MM				

EXPLODED VIEW — LP GENERATOR

Drawing No. A6413-G

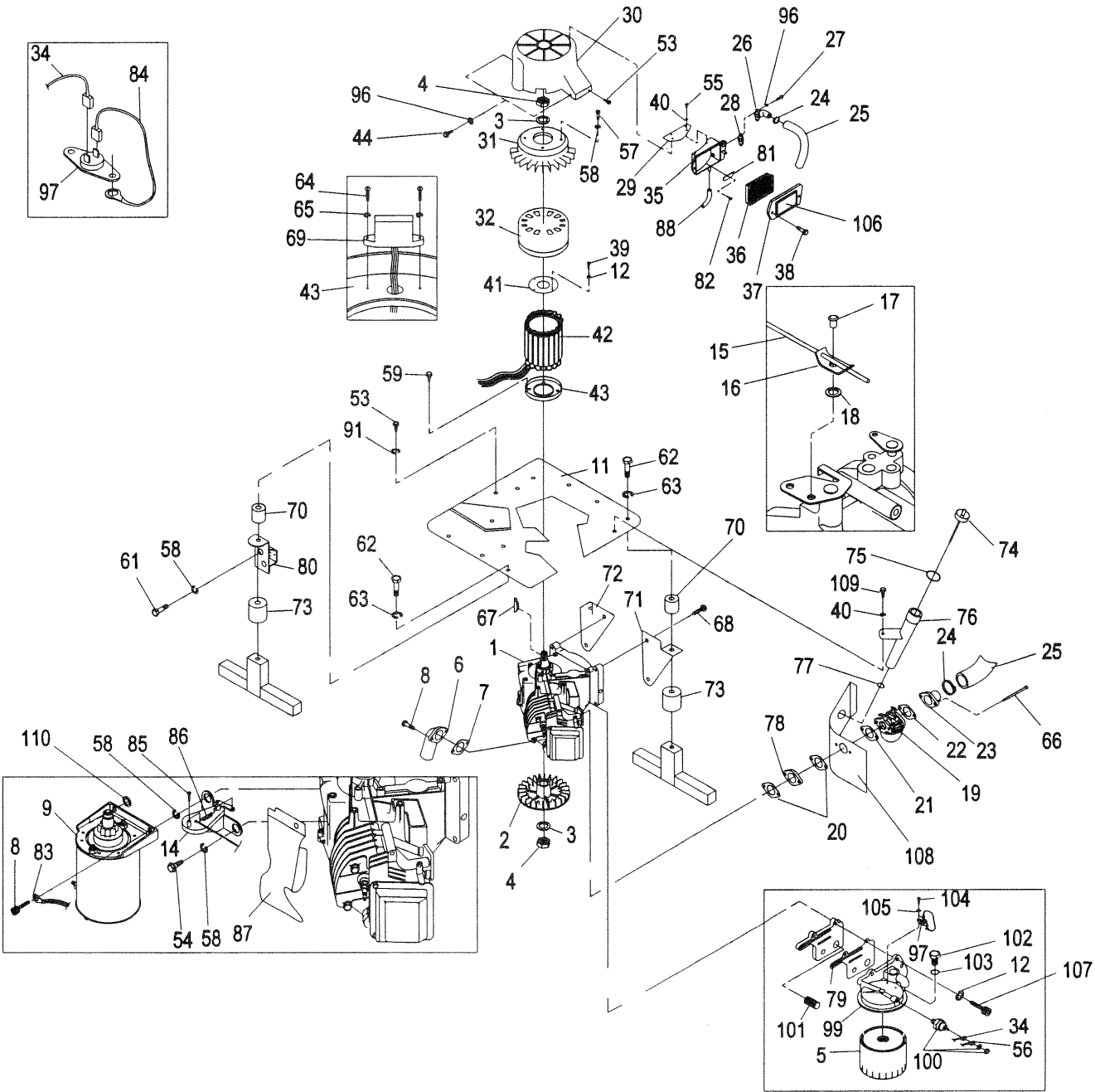

REPAIR PARTS — LP GENERATOR

Drawing No. A6413-G

ITEM	PART NO.	QTY.	DESCRIPTION	ITEM	PART NO.	QTY.	DESCRIPTION
1	A2467	1	ENGINE, LONG BLOCK	58	22129	10	LOCK WASHER-M8
2	94583	1	FLYWHEEL, FAN	59	74906	4	M6-1 x 20MM TAPTITE
3	83312	2	WASHER, CONICAL	61	39253	3	HEX HD. CAPSCR., M8-1.25 x 20MM
4	81810	2	HEX NUT, M16-1.5	62	22511	3	HEX HD. CAPSCR., 3/8"-16 x 1.25"
5	70185	1	FILTER, OIL	63	22237	3	LOCK WASHER-3/8"
6	86730	1	TUBE, EXHAUST OUTLET	64	55822	2	PHMS, M4-0.7 x 8MM
7	89476	1	GASKET, EXHAUST	65	22264	2	LOCK WASHER-M4
8	40976	4	SOCKET HD. CAPSCR., M8-1.25 x 20MM	66	89050	2	PHILLIPS PAN HD. MACH. SCREW-M6-1 x 90MM
9	99948	1	STARTER MOTOR	67	82774	1	WOODRUFF KEY-4 x 19MM
11	86705	1	PLATE, DIVIDER	68	59637	4	TAPTITE 3/8"-16 x .75"
12	22097	8	LOCK WASHER, 1/4"-M6	69	86697	1	ASSEMBLY IGNITION SENSOR
14	92059	1	STEPPER MOTOR SPEED CONTROL	70	86704	3	SPACER, ENGINE MOUNT
15	86706	1	ROD, THROTTLE CONTROL	71	86701	1	BRACKET, ENGINE MOUNT FRONT
16	89477	1	CLIP, ADJUSTMENT	72	86702	1	BRACKET, ENGINE MOUNT REAR
17	89478	1	SNAP, RETAINING	73	38353	3	RUBBER MOUNTS
18	90192	1	WASHER, CARBURETOR	74	89263	1	ASSEMBLY, OIL FILL CAP
19	A2774A	1	CARBURETOR ASSEMBLY	75	90071	1	O-RING, 1.062" I.D.
20	90051	2	GASKET, CARBURETOR/ SPACER/HEAD	76	94637	1	OIL FILL TUBE
21	78631	1	GASKET, CARBURETOR/SKIRT	77	90072	1	O-RING .562" I.D.
22	96459	1	GASKET, CARBURETOR/INLET ADAPTOR	78	86708	1	CARBURETOR SPACER
23	86709	1	ADAPTOR, CARBURETOR INLET	79	87478	1	GASKET, OIL FILTER ADAPTOR
24	35586	2	HOSE CLAMP-BAND #20	80	96627	1	BRACKET, STARTER SIDE ENGINE MNT.
25	86710	1	HOSE, CARBURETOR INLET	81	90613	1	COVER, BREATHER CANAL
26	87993	1	ELBOW, AIR CLEANER OUTLET	82	59635	1	#8 x 3/8" PLASTITE SCREW
27	49815	2	HEX HD. CAPSCR., M5-.8 x 16MM	83	002-91297	1	STARTER WIRE
28	90536	1	GASKET, AIR CLEANER OUTLET	84	004-91297	1	TEMP SWITCH GROUND WIRE
29	90021	1	BRACKET, AIR CLEANER SUPPORT	85	59636	1	PLASTITE SCREW, #4 x .37"
30	94665	1	HOUSING, FAN-UPPER	86	88905	1	EXTENSION SPRING
31	93859	1	FAN, GENERATOR	87	92800	1	WRAPPER, ENGINE TOP
32	A5892	1	ASSEMBLY, MAGNET HOUSING	88	89062	1	HOSE, BREATHER
34	003-91297	1	TEMP. SWITCH WIRE	91	22447	3	WASHER, INTERNAL SHAKEPROOF, .25"
35	86673	1	BASE, AIR BOX	96	23897	6	#10-M5 FLAT WASHER
36	78601	1	ELEMENT, AIR FILTER	97	94090	1	SWITCH, THERMAL OIL TEMP.
37	86674	1	COVER, AIR BOX	99	86675A	1	ADAPTOR, OIL FILTER
38	78609	2	BOLT, AIR CLEANER COVER	100	77667	1	4 PSI OIL PRESSURE SWITCH
39	66449C	4	HEX HD. CAPSCR., M6-1 x 80MM	101	86714	1	SCREEN, OIL PICK-UP
40	49226	4	LOCK WASHER, M5	102	52617	1	DRAIN PLUG, M12-1.75 x 20MM
41	80934	1	RETAINING RING, STATOR	103	C2908	1	GASKET, OIL DRAIN PLUG
42	A6420	1	ASSEMBLY STATOR	104	C1085	2	PPHMS, M3-0.5 x 8MM
43	86692	1	ADAPTOR, STATOR	105	43182	2	LOCK WASHER-M3
44	74908	3	TAPTITE, M5-0.8 x 10MM	106	C2333A	1	A/C DECAL
53	45756	3	M6-1 x 10MM TAPTITE	107	97962	4	SHCS, M6-1.0 x 25 LG
54	83512	1	TAPTITE M8-1.25 x 15MM	108	86726	1	SKIRT, BAFFLE
55	52618	5	HEX HD. CAPSCR., M5-0.8 x 12MM	109	56893	1	CRIMPTITE #10-24 x 1/2"
56	005-91297	1	OIL PRESSURE SWITCH WIRE	110	A9257	1	SHIM, STARTER
57	42907	3	HEX HD. CAPSCR., M8-1.25 x 16MM				

EXPLODED VIEW — ENGINE LONG BLOCK
Drawing No. A6202-D

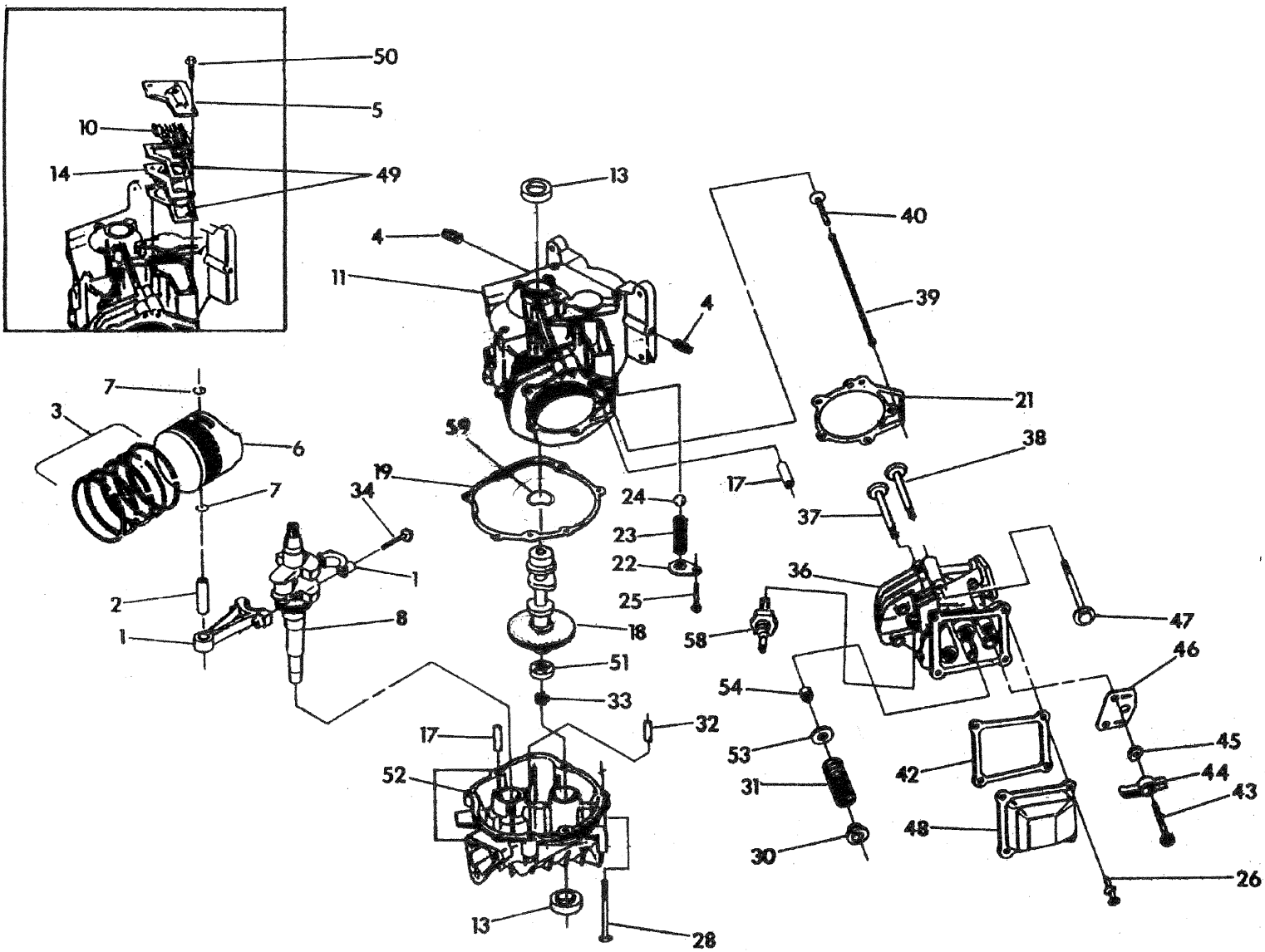

REPAIR PARTS — ENGINE LONG BLOCK

Drawing No. A6202-D

ITEM	PART NO.	QTY.	DESCRIPTION
1	78621	1	ASSEMBLY, CONNECTING ROD & CAP
2	76389	1	PISTON PIN
3	88411	1	SET, PISTON RING (STD. SIZE)
4	72657	2	PIPE PLUG-1/4" NPT
5	77176	1	COVER, BREATHER
6	88057	1	PISTON, 75 DIA.
7	76390	2	RETAINER, PISTON PIN
8	83379A	1	ASSEMBLY, CRANKSHAFT AND GEAR
10	89923	1	SEPARATOR, OIL BREATHER
11	89213L	1	ASSEMBLY, CRANKCASE
13	81695	2	SEAL, OIL-CRANKSHAFT
14	90604	1	CUP, BREATHER BAFFLE
17	78699B	3	SLEEVE, DOWEL DIA. 12
18	A9878	1	ASSEMBLY, CAMSHAFT
19	89096	1	GASKET, CRANK CASE FLANGE
21	A8822	1	GASKET, CYLINDER HEAD
22	78691	1	RETAINER, OIL PRESSURE SPRING
23	A5772	1	SPRING, OIL PRESSURE
24	A5776	1	BALL, OIL PRESSURE
25	74908	1	TAPTITE, M5-0.8 X 10
26	78606	4	SCREW & LOCK WASHER, M6-1 x 12 LONG
28	89230	6	HHFC, M8-1.25 x 35 LONG
30	A1720	2	RETAINER, VALVE SPRING
31	88401	2	SPRING, VALVE
32	88590	1	DOWEL PIN, DIA.12 x 18 LONG
33	83152	1	GEROTOR, INNER
34	76381	2	BOLT, CONNECTING ROD
36	21705B	1	ASSEMBLY, CYLINDER HEAD W/GUIDES & SEATS
37	90082	1	VALVE, EXHAUST
38	90081	1	VALVE, INTAKE
39	88396A	2	PUSH ROD
40	83235	2	TAPPET
42	96362	1	GASKET, ROCKER COVER
43	77161	2	STUD, BALL PIVOT
44	77160	2	ROCKER ARM
45	76307	2	NUT, ROCKER ARM
46	88403	1	PLATE, PUSH ROD GUIDE
47	77168	5	HEADBOLT, M8 x 56MM
48	88413B	1	COVER, ROCKER
49	78629	2	GASKET, BREATHER
50	90388	2	BOLT, TAPTITE-M6 x 12 LONG
51	83153	1	GEROTOR, OUTER
52	92977	1	ASSEMBLY-SUMP, OIL
53	84186	2	WASHER, WEAR-VALVE SPRING
54	88156	1	SEAL VALVE-INTAKE
58	72347	1	SPARKPLUG, CHAMPION
59	99922	1	WASHER, WAVE

EXPLODED VIEW — CONTROL PANEL

Drawing No. A9192-B

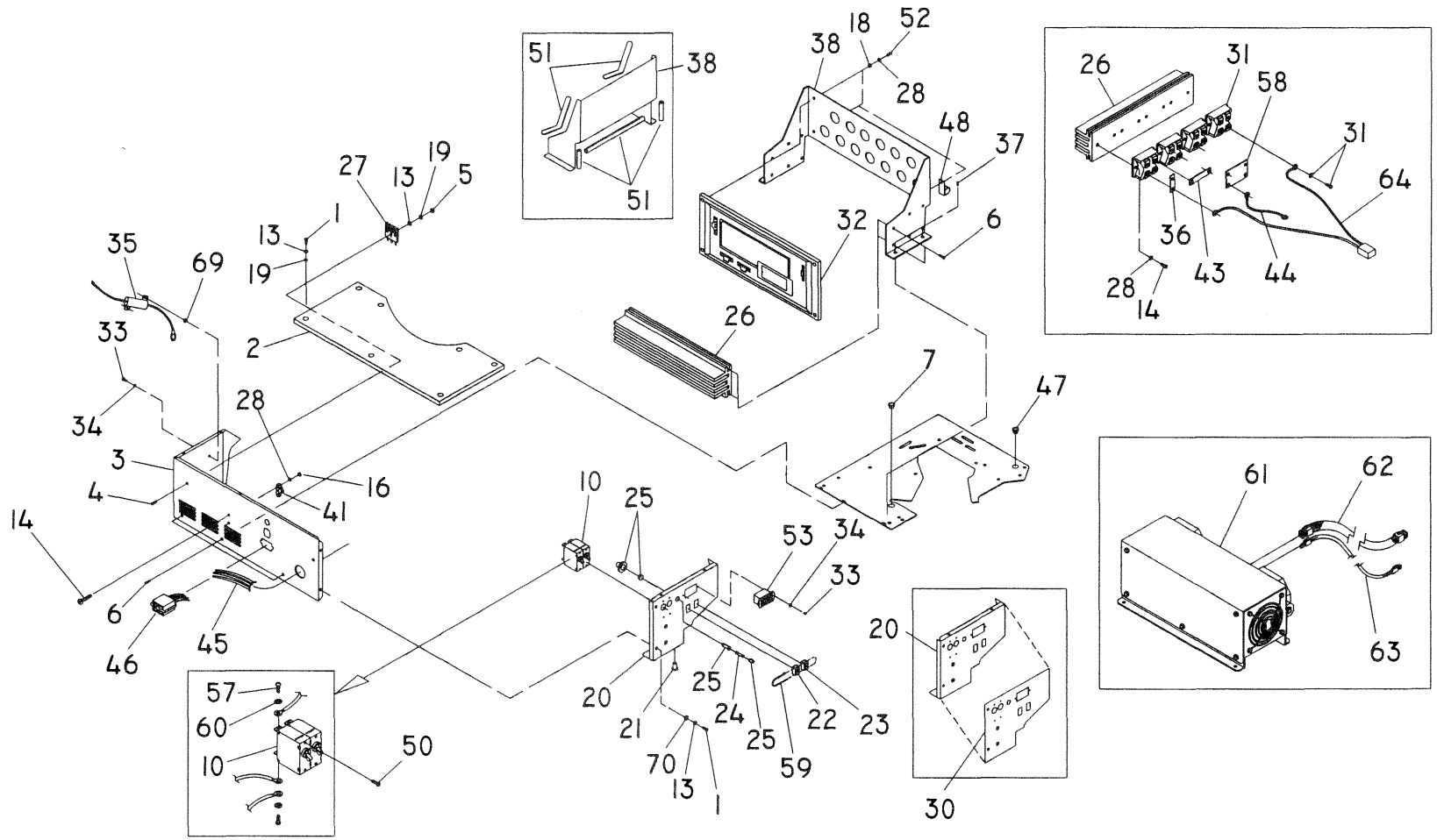

**ITEMS #49, 65 & 66-HARNESSES- NOT SHOWN FOR CLARITY

REPAIR PARTS — CONTROL PANEL

Drawing No. A9192-B

ITEM	PART NO.	QTY.	DESCRIPTION	ITEM	PART NO.	QTY.	DESCRIPTION
1	91526	7	M5-0.8 x 12MM PHILLIPS PAN HD. MACH. SCR.	36	A6423A	2	BUS BAR, OUTER
2	20093	1	BOX, CONTROL TOP	37	45756	4	TAPTITE M6- 1.0 x 10MM
3	A9180	1	BOX, CONTROL PANEL	38	86722	1	BRACKET, HEAT SINK-PCB
4	36937	1	#10-32 x 1" PHILLIPS PAN HD. MACH. SCR.	41	75210A	1	TERMINAL BLOCK
5	22158	1	#10-32 HEX NUT	43	A6423B	4	BUS BAR, INNER
6	74908	8	TAPTITE M5- .8 x 10MM	44	025-91297	1	GROUND WIRE
7	23484M	1	SNAP BUSHING	45	A6470	1	DC POWER HARNESS
10	A8592	1	CIRCUIT BREAKER, 15A.	46	91269A	1	REMOTE PANEL HARNESS
13	49226	6	LOCK WASHER-M5	47	23484D	1	SNAP BUSHING
14	75476	10	M4-0.7 x 16MM	48	82121A	1	CLAMP, CONTROL PANEL HARNESS
16	51715	2	M4-0.7 HEX NUT	49	A9183	1	HARNESS, CONTROL PANEL
18	22985	4	M4 FLAT WASHER	50	25105	4	#6-32 x 1/4" PHILLIPS ROUND HD. MACH. SCREW
19	23897	8	M5 FLAT WASHER	51	84867	5	RUBBER U-CHANNEL
20	A9179	1	CONTROL PANEL, FRONT	52	51718	4	M4-0.7 x 10MM HEX HEAD CAPSCREW
21	30809	1	RUBBER GROMMET	53	C1457	1	HOUR METER
22	87798	1	SWITCH, SPDT ROCKER	57	36933	4	PPHMS 10-32 x 3/8" LG
23	92113	1	SWITCH, SPSTMOM ROCKER	58	A6423C	1	BUS BAR, CENTER
24	A9611	1	FUSE, 7.5A. AGC	59	29333A	1	BLACK TIE WRAP, 7" LG
25	32300	1	FUSE HOLDER	60	23762	4	SHAKEPROOF EXT. #10
26	A6422	1	EXTRUSION, CONTROLLER	61	A6187	1	INVERTER ASSEMBLY
27	65795	1	RECTIFIER, BATTERY CHARGE	62	A6429	1	WIRE HARNESS, 7 CONDUCTOR
28	22264	14	LOCK WASHER-M4	63	A6430	1	WIRE HARNESS, 2 CONDUCTOR
30	C2336	1	PANEL DECAL	64	A6464	1	WIRE HARNESS-HEATSINK TO PCBI
31	96874	4	DIODE, DUAL 30A	65	A6516	1	HARNESS-PCBI TO PANEL
32	A6060	1	ASSEMBLY, PCB CCG	66	A6700	1	HARNESS-HEATSINK TO TERM. BLOCK
33	43181	4	PHMS M3-.05 x 10MM	69	51714	2	M3-0.5 NUT
34	43182	4	LOCK WASHER-M3	70	20769	2	M6 FLAT WASHER
35	89744	1	RESISTOR, POWER 1 OHM				

EXPLODED VIEW — LP ENGINE SHEET METAL

Drawing No. A9193-D

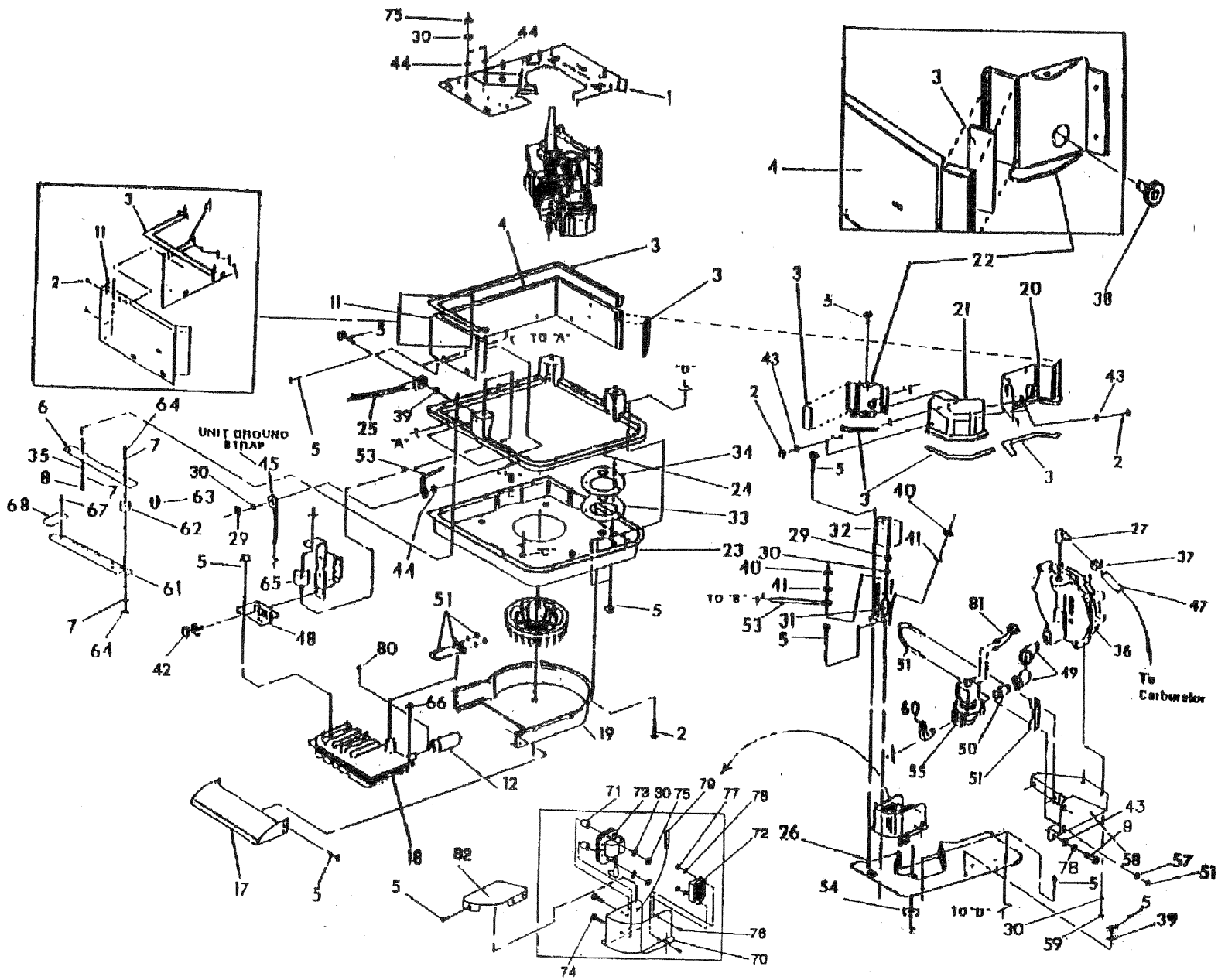

REPAIR PARTS — LP ENGINE SHEET METAL

Drawing No. A9193-D

ITEM	PART NO.	QTY.	DESCRIPTION	ITEM	PART NO.	QTY.	DESCRIPTION
1	86705	1	PLATE, DIVIDER	45	103-74260	1	GROUND STRAP, UNIT
2	56893	32	CRIMPTITE 10-24 x 1/2"	47	47290	1	HOSE-3/8" I.D. x 11-1/2" LONG
3	86718	3.5'	SEAL, RUBBER EXTRUSION	48	92000	1	BRACKET, MUFFLER HANGER
4	A3666	1	BOX, WRAPPER	49	25425	2	STREET ELBOW 45 DEG. 3/4" NPT
5	74908	31	TAPTITE, M5-.8 x 10MM	50	26490	1	PIPE NIPPLE 3/4" x 2"
6	A3667	2	MOUNTING RAILS	51	94670	2	U BOLT W / SADDLE & 2-NUTS
7	22129	12	M8 LOCK WASHER	53	007-91297	1	STARTER CONTACTOR GROUND WIRE
8	39414	4	M8-1.25 x 35MM HEX HD. CAPSCR.	54	89045	1	SEAL, WASHER EXHAUST PIPE
9	50830	3	HHCS M5-0.8 x 40MM	55	A2666	1	FUEL SOLENOID 12V DC
11	A3638	1	WRAPPER, END PANEL	57	22145	2	5/16" FLAT WASHER
12	89680	1	SPARK ARRESTER	58	A4603	1	BRACKET LP
17	89471	1	DEFLECTOR, AIR OUT	59	22507	2	CAPSCR., HEX HD.-1/4"-20 x 1/2"
18	86731A	1	ASSEMBLY, MUFFLER	60	A5606	1	LP HOOK-UP FITTING
19	86715	1	HOUSING, LOWER FAN	61	A3764	2	CUSTOMER MOUNTING BRACKET
20	86726	1	SKIRT, CARB. BAFFLE	62	66443B	4	VIBRATION MOUNT
21	86671	1	COVER, ROCKER COVER	63	20668	2	EARTHING STRAP
22	86727	1	SKIRT, SPARK PLUG SIDE	64	45771	8	HEX NUT-M8
23	86719	1	PAN, BELLY	65	38353	3	VIBRATION MOUNT
24	C3296	1	FRAME	66	56892	1	CRIMPTITE #10-24 x 3/8"
25	90141A	1	GROUND STRAP	67	79119	1	1/4"-20 TAPTITE 1-1/4"
26	86724	1	PLATE, BASE COVER	68	A7213	1	TAG, BOLT REMOVAL
27	43790	1	BARBED 90 DEG. 3/8" x 3/8" FITTING	70	A9172	1	BRACKET, IGNITION SYSTEM
29	22127	5	HEX NUT, 1/4"-20	71	89047	2	SPACER, IGNITION COIL
30	22097	9	LOCK WASHER-1/4"-M6	72	86711	1	MODULE, IGNITION
31	86729	1	CONTACTOR, STARTER	73	89049B	1	ASSEMBLY, IGNITION COIL
32	90518	1	BOOT, CONTACTOR	74	49721	2	M6-1.0 x 35MM HEX HD. CAPSCREW
33	89048	1	SEAL, OIL FILTER HOLE	75	49813	4	M6-1.0 HEX NUT
34	90537	1	RETAINER, SEAL	76	91526	2	M5-0.8 x 12MM PHILLIPS PAN HD. MACH. SCR.
35	22145	4	FLAT WASHER-M8	77	51716	2	M5-0.8 HEX NUT
36	75211	1	REGULATOR	78	49226	5	LOCK WASHER, M5
37	40173	1	HOSE CLAMP #5.5	79	84867	2.5"	RUBBER "U" CHANNEL
38	23484D	1	SNAP BUSHING	80	56892	1	CRIMPTITE #10-24 x 3/8"
39	23762	2	EXTERNAL SHAKEPROOF-#10	81	A9031	1	WIRE ASSEMBLY, BLOCKING DIODE
40	22471	2	#8-32 HEX NUT	82	A9196	1	COVER, IGNITION BRACKET
41	22264	2	#8 LOCK WASHER				
42	79246	2	HEX HD. CAPS., M6-1.0 x 16MM-W/L-WASHER				
43	23897	7	FLAT WASHER #10/M5				
44	22447	3	WASHER, INTERNAL SHAKEPROOF, 1/4"-M6				

EXPLODED VIEW — GASOLINE ENGINE SHEET METAL

Drawing No. A9194-C

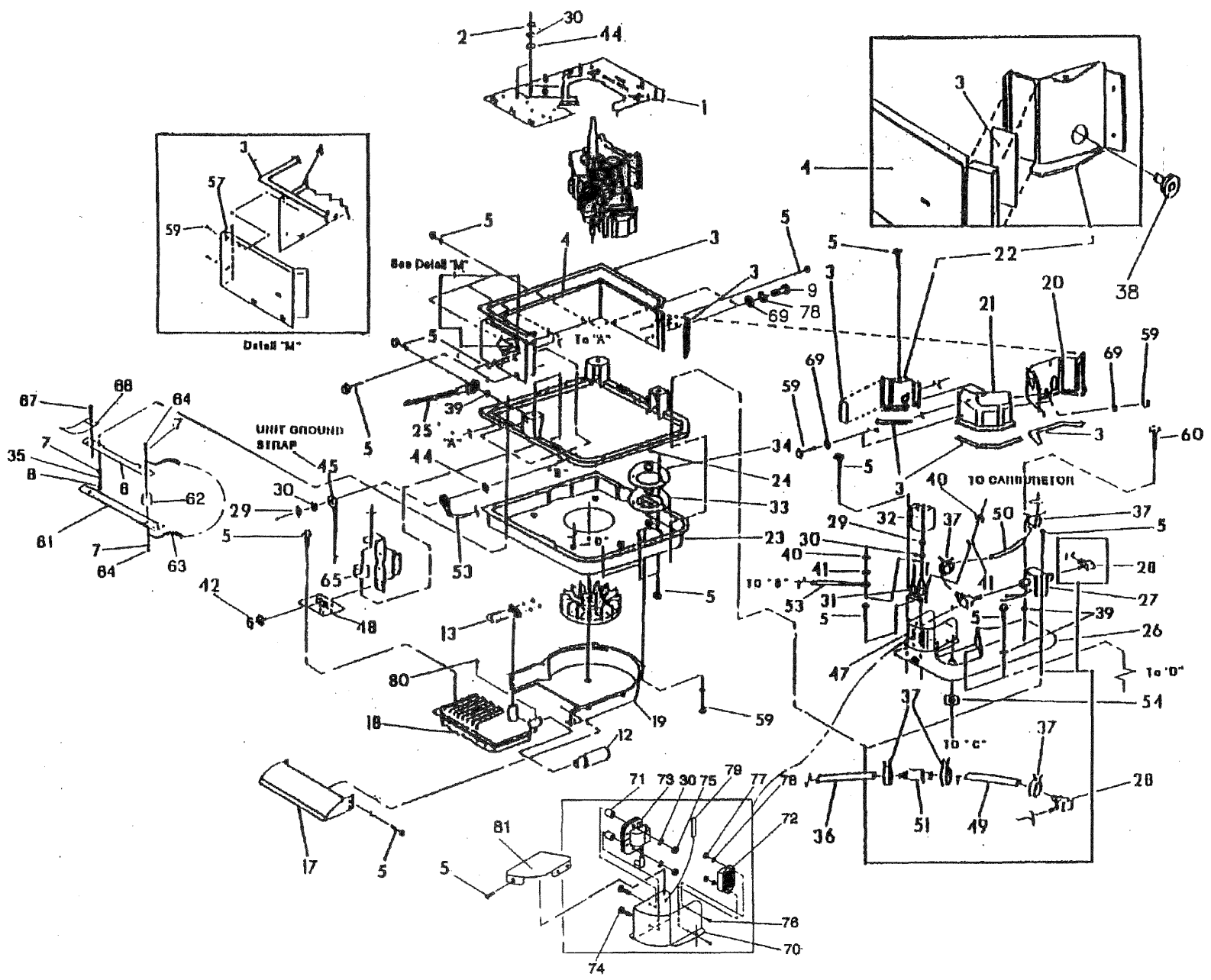

REPAIR PARTS — GASOLINE ENGINE SHEET METAL

Drawing No. A9194-C

ITEM	PART NO.	QTY.	DESCRIPTION	ITEM	PART NO.	QTY.	DESCRIPTION
1	86705	1	PLATE, DIVIDER	42	79246	2	HEX HD. CAPSCR. M6-1.0 x 16MM- W/LOCK WASHER
2	49813	2	M6-1.0 HEX NUT	44	22447	3	WASHER, INTERNAL SHAKEPROOF, 1/4"/M6
3	86718	3.5"	SEAL RUBBER EXTRUSION	45	103-74260	1	GROUND STRAP, UNIT
4	A3666	1	WRAPPER, BOX	47	39450	1	1/8" x 3/16" NPT 90 DEG. BARBED FITTING
5	74908	31	TAPTITE, M5- .8 x 10MM LONG	48	92000	1	BRACKET, MUFFLER HANGER
6	A3667	2	MOUNTING RAILS	49	30340	1	1/4" FUEL LINE (8" LONG)
7	22129	12	M8 LOCK WASHER	50	82580D	1	3/16" CARBURETOR LINE (4" LONG)
8	39414	4	M8-1.25 x 35MM HEX HD. CAPSCR.	51	86311	1	FUEL FILTER
9	50830	2	HHCS M5-0.8 x 40MM	53	007-91297	1	STARTER CONTACTOR GROUND WIRE
12	89680	1	SPARK ARRESTOR	54	89045	1	SEAL, WASHER EXHAUST PIPE
13	94670	1	U-BOLT, W/SADDLE & NUTS	57	A3638	1	PANEL, WRAPPER BOX
17	89471	1	DEFLECTOR, AIR OUT	59	56893	13	CRIMPTITE #10-24 x 1/2"
18	86731A	1	ASSEMBLY, MUFFLER	60	A5767	1	HEX HD. CAPSCR., M5-0.8 x 6MM
19	86715	1	HOUSING, LOWER FAN	61	A3764	2	CUSTOMER MOUNTING BRACKET
20	86726	1	SKIRT, CARB. BAFFLE	62	66443B	4	VIBRATION MOUNT
21	86671	1	COVER, ROCKER COVER	63	20668	2	EARTHING STRAP
22	86727	1	SKIRT, SPARK PLUG SIDE	64	45771	8	HEX NUT M8
23	86719	1	PAN, BELLY	65	38353	3	VIBRATION MOUNT
24	C3296	1	FRAME	67	79119	2	TAPTITE 1/4"-20 x 1-1/4"
25	90141A	1	GROUND STRAP	68	A7213	2	TAG, REMOVE BOLT
26	86724	1	PLATE, BASE COVER	69	23897	6	FLAT WASHER #10-M5
27	90475	1	PUMP, FUEL	70	A9172	1	BRACKET, IGNITION SYSTEM
28	28740	1	BARBED 90 1/8" x 1/4"	71	89047	2	SPACER, IGNITION COIL
29	22127	3	HEX NUT 1/4"-20	72	86711	1	MODULE, IGNITION
30	22097	7	LOCK WASHER-1/4"-M6	73	89049B	1	ASSEMBLY, IGNITION COIL
31	86729	1	CONTACTOR, STARTER	74	49721	2	M6-1.0 x 35MM HEX HD. CAPSCREW
32	90518	1	BOOT, CONTACTOR	75	49813	4	M6-1.0 HEX NUT
33	89048	1	SEAL, OIL FILTER HOLE	76	91526	2	M5-0.8 x 12MM-PPHMS
34	90537	1	RETAINER, SEAL	77	51716	2	M5-0.8 HEX NUT
35	22145	4	M8 FLAT WASHER	78	49226	4	LOCK WASHER M5
36	30340	1	1/4" FUEL LINE-4" LONG	79	84867		.25" RUBBER "U" CHANNEL
37	48031C	5	1/4" HOSE CLAMP	80	56892	1	CRIMPTITE #10-24 x 3/8"
38	23484D	1	SNAP BUSHING	81	A9196	1	COVER, IGNITION SYSTEM
39	23762	2	EXTERNAL SHAKEPROOF				
40	22471	2	#8 HEX NUT				
41	22264	2	#8 LOCK WASHER				

CALIFORNIA AND FEDERAL EMISSION CONTROL WARRANTY STATEMENT

YOUR WARRANTY RIGHTS AND OBLIGATIONS

The California Air Resources Board (CARB) and the United States Environmental Protection Agency (EPA), together with Generac Power Systems, Inc. (Generac), are pleased to explain the Emission Control System Warranty on your new engine.* New utility, and lawn and garden equipment engines must be designed, built and equipped to meet stringent anti-smog standards for the state of California and the federal government. Generac will warrant the emission control system on your engine for the periods of time listed below provided there has been no abuse, neglect, unapproved modification or improper maintenance of your engine.

Your emission control system may include parts such as the carburetor, ignition and exhaust systems. Generac will repair your engine at no cost to you for diagnosis, replacement parts and labor, should a warrantable condition occur.

MANUFACTURER'S EMISSION CONTROL SYSTEM WARRANTY COVERAGE:

Emissions control systems on 1997 and later model year engines are warranted for two years as hereinafter noted. If, during such warranty period, any emission-related component or system on your engine is found to be defective in materials or workmanship, repairs or replacement will be performed by a Generac Authorized Warranty Service Facility.

PURCHASER'S/OWNER'S WARRANTY RESPONSIBILITIES:

As the engine purchaser/owner, you are responsible for the completion of all required maintenance as listed in your factory supplied *Owner's Manual*. For warranty purposes, Generac recommends that you retain all receipts covering maintenance on your engine. However, Generac cannot deny warranty solely because of the lack of receipts or for your failure to ensure the completion of all scheduled maintenance.

As the engine purchaser/owner, you should, however, be aware that Generac may deny any and/or all warranty coverage or responsibility if your engine, or a part/component thereof, has failed due to abuse, neglect, improper maintenance or unapproved modifications, or the use of counterfeit and/or "grey market" parts not made, supplied or approved by Generac.

You are responsible for presenting your engine to a Generac Authorized Warranty Service Facility as soon as a problem occurs. The warranty repairs should be completed in a reasonable amount of time, not to exceed 30 days.

Warranty service can be arranged by contacting either your selling dealer or a Generac Authorized Warranty Service Facility. To locate the Generac Authorized Warranty Service Facility nearest you, call our toll-free number:

1-800-333-1322

IMPORTANT NOTE: This warranty statement explains your rights and obligations under the Emission Control System Warranty (ECS Warranty), which is provided to you by Generac pursuant to California and federal law. See also the "Generac Limited Warranties for Generac Power Systems, Inc.," which is enclosed herewith on a separate sheet, also provided to you by Generac. The ECS Warranty applies **only** to the emission control system of your new engine. If there is any conflict in terms between the ECS Warranty and the Generac Warranty, the ECS Warranty shall apply except in circumstances where the Generac Warranty may provide a longer warranty period. Both the ECS Warranty and the Generac Warranty describe important rights and obligations with respect to your new engine.

Warranty service can be performed only by a Generac Authorized Warranty Service Facility. When requesting warranty service, evidence must be presented showing the date of the sale to the original purchaser/owner. The purchaser/owner shall be responsible for any expenses or other charges incurred for service calls and/or transportation of the product to/from the inspection or repair facilities. The purchaser/owner also shall be responsible for any and/or all damages or losses incurred while the engine is being transported/shipped for inspection or warranty repairs.

If you have any questions regarding your warranty rights and responsibilities, you should contact Generac at the following address:

ATTENTION WARRANTY DEPARTMENT
GENERAC POWER SYSTEMS, INC.
P.O. BOX 8
WAUKESHA, WI 53187

Part 1

EMISSION CONTROL SYSTEM WARRANTY

Emission Control System Warranty (ECS Warranty) for 1997 and later model year engines:

- (a) Applicability: This warranty shall apply to 1997 and later model year engines. The ECS Warranty Period shall begin on the date the new engine or equipment is purchased by/delivered to its original, end-use purchaser/owner and shall continue for 24 consecutive months thereafter.
- (b) General Emissions Warranty Coverage: Generac warrants to the original, end-use purchaser/owner of the new engine or equipment, and to each subsequent purchaser/owner, that each of its engines is ...
- (1) Designed, built and equipped so as to conform with all applicable regulations adopted by the EPA and CARB pursuant to their respective authority, and
 - (2) Free from defects in materials and workmanship which, at any time during the ECS Warranty Period, may cause a warranted emissions-related part to fail to be identical in all material respects to the part as described in the engine manufacturer's application for certification.
- (c) The ECS Warranty only pertains to emissions-related parts on your engine, as follows:
- (1) Any warranted, emissions-related parts that are not scheduled for replacement as required maintenance in the *Owner's Manual* shall be warranted for the ECS Warranty Period. If any such part fails during the ECS Warranty Period, it shall be repaired or replaced by Generac according to Subsection (4) below. Any such part repaired or replaced under the ECS Warranty shall be warranted for the remainder of the ECS Warranty Period.
 - (2) Any warranted, emissions-related part that is scheduled only for regular inspection as specified in the *Owner's Manual* shall be warranted for the ECS Warranty Period. A statement in such written instructions to the effect of "repair or replace as necessary" shall not reduce the ECS Warranty Period. Any such part repaired or replaced under the ECS Warranty shall be warranted for the remainder of the ECS Warranty Period.
 - (3) Any warranted, emissions-related part that is scheduled for replacement as required maintenance in the *Owner's Manual* shall be warranted for the period of time prior to the first scheduled replacement point for that part. If the part fails prior to the first scheduled replacement, the part shall be repaired or replaced by Generac according to Subsection (4) below. Any such emissions-related part repaired or replaced under the ECS Warranty shall be warranted for the remainder of the ECS Warranty Period prior to the first scheduled replacement point for such emissions-related part.
 - (4) Repair or replacement of any warranted, emissions-related part under this ECS Warranty shall be performed at no charge to the owner at a Generac Authorized Warranty Service Facility.
 - (5) When the engine is inspected by a Generac Authorized Warranty Service Facility, the owner shall not be held responsible for diagnostic costs if the repair is deemed warrantable.
 - (6) Generac shall be liable for damages to other original engine components or approved modifications proximately caused by a failure under warranty of any emission-related part covered by the ECS Warranty.
 - (7) Throughout the ECS Warranty Period, Generac shall maintain a supply of warranted emission-related parts sufficient to meet the expected demand for such emission-related parts.
 - (8) Any Generac authorized and approved emission-related replacement part may be used in the performance of any ECS Warranty maintenance or repairs and will be provided without charge to the purchaser/owner. Such use shall not reduce Generac's ECS Warranty obligations.
 - (9) Unapproved, add-on, modified, counterfeit and/or "grey market" parts may not be used to modify or repair a Generac engine. Such use voids this ECS Warranty and shall be sufficient grounds for disallowing an ECS Warranty claim. Generac shall not be held liable hereunder for failures of any warranted parts of a Generac engine caused by the use of such an unapproved, add-on, modified, counterfeit and/or "grey market" part.

EMISSION RELATED PARTS INCLUDE THE FOLLOWING:

- | | |
|---|---|
| 1) Fuel Metering System: | 2) Air Induction System including: |
| 1.1) Gasoline carburetor assembly and its internal components (if so equipped). | a) Intake pipe/manifold |
| a) Fuel filter (if so equipped) | b) Air cleaner |
| b) Carburetor gaskets | 3) Ignition System including: |
| c) Fuel pump (if so equipped) | a) Spark plug |
| 1.2) LPG carburetion assembly and its internal components (if so equipped). | b) Ignition module |
| a) Fuel controller (if so equipped) | 4) Catalytic Muffler Assembly (if so equipped) including: |
| b) Mixer and its gaskets (if so equipped) | a) Muffler gasket |
| c) Carburetor and its gaskets (if so equipped) | b) Exhaust manifold |
| d) Primary gas regulator (if so equipped) | 5) Crankcase Breather Assembly including: |
| e) LP liquid vaporizer (if so equipped) | a) Breather connection tube |

*Generac engine types covered by this warranty statement include the following:

- 1) Utility
- 2) Lawn and Garden Equipment
- 3) Recreational Vehicle (RV) Generator
- 4) Industrial Mobile (IM) Generator

Part 2

Generac's Three-Year Limited Warranty For Recreational Vehicle Generators

Generac warrants to the original owner and subsequent purchasers from the date of purchase by the original owner, that its generators will be free from defects in materials or workmanship for the period as set forth below. During said warranty period, Generac will, at its option, repair or replace any part which, upon examination by Generac or a Generac Authorized Distributor and/or Dealer thereof, is found to be defective from normal use and service.

This warranty is only effective, upon Generac's receipt from the original owner, a completed Warranty Registration Card, prior to the expiration of the warranty period. This card is the only valid registration identification and must be presented at time of requesting Warranty service. Claims will not be accepted without presentation of this Registration Card.

THREE YEAR WARRANTY SCHEDULE

1. All generators used in a recreational vehicles shall be warranted for a period of three (3) years or 2,000 hours of operation, whichever occurs first. All parts, labor, removal and reinstallation shall be covered for the first two years. Parts and labor on selected generator and engine parts shall be covered during the third year or 2,000 hours, whichever occurs first. These selected parts are limited to: the main Rotor and Stator, Computer Control board (if applicable) with regard to the generator; the Cylinder Block, Cylinder Head, Crankshaft, Piston, Valve, Valve Lifter, and Manifolds with regard to the engine.
2. The drive belt and pulleys (if so equipped) on air-cooled generator used in recreational vehicles shall be warranted against failure due to defective materials or normal usage for the life of the generator. For the original owner, this drive belt and pulley warranty shall include parts and labor plus \$50.00 payment upon return of the failed belt or pulley by the original owner. For succeeding owners, this drive belt warranty shall cover belt or pulley parts only.
3. Rental units, demonstrators, prime power, or commercial applications, such as construction or utility, are warranted for (1) one year or 2,000 hours, whichever comes first.
4. This transferable warranty is in effect for all Recreational Vehicle Generators purchased after Jan. 1, 1998.

THIS WARRANTY DOES NOT COVER:

- Costs of maintenance, installation, and start-up.
- Failures due to (a) normal wear and tear from GN engine, or (b) accident, misuse, abuse, negligence or improper installation.
- Products which are modified or altered in a manner not authorized by Generac in writing.
- Any incidental, consequential or indirect damages caused by defects in materials or workmanship, or any delay in repair or replacement of defective parts.
- Failure due to misapplication.
- Telephone, telegraph, teletype or other communication expense.
- Living or travel expenses of persons performing service.
- Any and all transportation/travel expenses.
- Rental equipment used while warranty repairs are being performed.
- Overtime labor.
- Starting batteries, fuses, light bulbs, and engine fluids.

****NORMAL WEAR: As with all mechanical devices, the GN-Series engines need periodic parts service and replacement to perform well. This warranty will not cover repair when normal use has exhausted the life of a part or an engine.**

There is no other express warranty. Generac hereby disclaims any and all implied warranties, including but not limited to those of merchantability and fitness for a particular purpose to the extent permitted by law. The duration of any implied warranties which cannot be disclaimed is limited to the time period (one year) as specified in the express warranty. Liability for consequential, incidental or special damages under any and all warranties is excluded to the extent permitted by law. Some states do not allow limitations on how long an implied warranty lasts, or the exclusion or limitation of incidental or consequential damages, so the above limitations or exclusions may not apply to you. This warranty gives you specific legal rights and you may also have other rights, which vary from state to state.

For service, see your nearest GENERAC authorized warranty service facility or call 1-800-526-2871. Warranty service can be performed only by a GENERAC authorized service facility. This warranty will not apply to service at any other facility. At the time of requesting warranty service, evidence of original purchase date must be presented.

Generac Power Systems, Inc.

P.O. Box 8

Waukesha, WI 53187