



Cummins **Onan**

Cummins **Onan**
RV Generator Handbook

Performance you rely on.™



Performance you rely on.™



Cummins Power Generation

1400 73rd Ave. NE
Minneapolis, MN 55432
USA
Phone 1 763 574 5000
Toll-free 1 800 888 6626
Fax 1 763 574 5298
Email www.cumminsonan.com/contact
www.cumminsonan.com

Cummins®, Onan®, the "C" logo, and Performance you rely on are registered trademarks of Cummins Inc.
©2007 Cummins Power Generation.
All Rights Reserved.





Introduction

Thank you for your interest in Cummins Onan RV generators - providing the quiet, reliable auxiliary power you need to make your life on the road all it can be. Cummins Onan generators are engineered for years of trouble-free service and our nation-wide service network is the largest in the industry. That's why Cummins Onan is the number one, best-selling line of installed generators in RV industry history.

Cummins Onan generators come in a wide variety of sizes and fuel types. From small gasoline, LP-liquid or vapor models to large diesel-powered models for bus-type Class A RVs, there's a model for whatever type of RVing you're interested in. And for 2008, we're introducing two new diesel-powered generators, the QD3200 for small type Cs and the unique new Hybrid Quiet Diesel power system, for larger, diesel-powered type A RVs.

This RV Generator Handbook contains basic information that will allow you to use and maintain your new generator. Included here are helpful tips for operation along with maintenance, parts and service information. This handbook is a general supplement to the more specific information contained in the Owner's Manual that comes with every new Cummins Onan generator.

Our promise to you is to continue to provide the best performing RV generators and the largest, best-trained service organization in the business. By following the tips contained here and having your Cummins Onan Authorized Parts and Service Distributor or Dealer provide service at recommended interval, your generator will provide reliable, easy-to-own performance for years to come.

Table of Contents

I. Important Safety Precautions	1
II. Quickstart Guide For New RV Generator Owners	3
III. Determining Which Cummins Onan Generator Model You Own	5
IV. RV Generator Operation	
• Load Management Basics	7
• Determining your Generator's Power Capability	7
• Common Power Requirements Chart	8
• Operating Motor Driven Appliances	9
• Air Conditioner "Short-Cycling"	9
• Effects Of High Altitude And Extreme Temperatures	9
• Starting and Stopping Procedures	10
• Breaking In Your New Generator	10
• Exercising Your Generator	10
• Managing Electrical Loads	11
• Battery Charger Loads	11
• Understanding Battery Charging Times	12
• Preventing Surging	13
• Noise Level Comparison Chart	14
V. Frequently Asked Questions (FAQs)	15-20
VI. Generator Care and Maintenance	
• General Generator Maintenance	21
• RV Generator Manuals Chart	22
• Maintenance Intervals Chart	23
• Do's And Don'ts For Better Generator Performance	25
• Keep Your Generator Clean and Inspect It Regularly for Damage	25
• Fuel Recommendations	26
• Oil Recommendations	26
• Coolant Recommendations	27
• Prevent Fuel Varnishing	28
• Troubleshooting Guide	29
• Service Diagrams	30-36
VII. Generator Maintenance: Parts and Chemicals	
• Insist On The Quality Of Green Label Parts™	37
• Use Cummins Onan® Oil And Service/Maintenance Chemicals To Insure Performance	39
• Green Label Parts Chart	40
VIII. Warranty and Service	45-50
IX. Current RV Generator/Accessory Model Information	51-69



I: Important Safety Precautions

Please read your generator Operator's Manual carefully so you understand all the precautions for safe, efficient operation. Most accidents occur from failing to follow fundamental safety rules. In general:

- Exhaust gas is deadly. Check all exhaust system connections regularly for leaks and tighten them as necessary. Do NOT operate the generator with a faulty exhaust system.
- If your RV bottoms out on a driveway or road object, inspect the generator exhaust system for damage. The tail pipe must extend past the edge of the vehicle.
- Always operate the generator in an area where the wind will carry away the exhaust fumes.
- Never sleep with the generator running unless the RV is equipped with an operating carbon monoxide detector.
- Don't store anything, especially gas, oil, rags or other flammable materials, in the generator compartment.
- Keep the exhaust and air intake free from obstructions such as clothing, furniture or other material, like road debris.

- Disable auto-start systems while refueling, servicing, storing or long-term parking.
- Perform all service and maintenance work with the generator engine off and the positive battery cable disconnected. Moving parts can cause severe personal injury or death, and live wires could cause fatal electrocution.
- Backfeed to utility systems can create serious risks to life or property. Do not connect the generator to a building electrical system except through an approved device and after the building's main breaker is opened.
- Autostart Caution: Be sure to deactivate your autostart system before storing your RV, conducting electrical maintenance, or handing over your RV to a service center. To be sure your generator won't start while conducting maintenance, follow the Operators Manual and disconnect the remote electrical harness prior to any service.

Statement Regarding Exhaust Extensions

Cummins Power Generation, manufacturer of Cummins Onan generator products, does not endorse the use of RV generator exhaust pipe extensions. Like all fuel burning devices, engine-driven generators emit carbon monoxide (CO) which, if not safely handled, can produce serious injury or death. Cummins Onan generators, in conjunction with RV OEM installed tailpipes, are designed to meet RVIA standards for safely handling exhaust gasses while minimizing noise and maximizing generator performance. Improper modifications to the exhaust components can result in unreasonable hazards to the vehicle occupants.

Cummins Power Generation has been unable to this date to identify any commercially available exhaust extension kit which meets reasonable standards for safely handling exhaust gases.

Cummins Power Generation's concerns revolve around 6 areas:

1. Weight: Unless entirely self supporting, extensions add weight to the end of the generator tail pipe which can stress and crack or break the exhaust system parts that are not designed to carry the additional weight. This could result in exhaust gases escaping directly under the coach, and therefore could be extremely dangerous to vehicle occupants.
2. Fit: To be effective conveyors of exhaust, connections & joints must be gas-tight. Such connections are not guaranteed unless the exhaust extension kit is properly assembled each time it is used.
3. Exhaust Direction: Because exhaust extensions vent at the roof line, there is a major concern that exhaust will be sucked in by rooftop air conditioners, vents and windows.
4. Heat: Many extension designs involve exposed metal that can be a burn hazard to anyone passing by who might contact the exposed extension pipe.
5. Backpressure: Adding an extension may increase backpressure on the engine, and thereby reduce engine performance or cause the engine to fail meeting government-regulated exhaust standards.
6. Warranty: The use of an exhaust extension kit may void the Cummins Onan warranty.



II: Quickstart Guide For New RV Generator Owners

There are some basic things that a new owner needs to know about his or her new Cummins Onan RV generator. First of all, become familiar with the basic safety rules, covered on the previous pages. Next, an understanding of the following key topics will help you get the most trouble-free, cost-effective auxiliary power while you're experiencing all that the RV lifestyle has to offer.

Starting and Stopping Procedures – it's very important to understand the correct way to turn your generator on and off. See page 10 for an in-depth explanation of this basic generator function.

Breaking In Your New Generator – following the recommended procedure for the initial running period can be beneficial for added service life. See page 10 to learn more about how to manage this important aspect of your new generator.

Exercising Your Generator – it's also very important to run your generator regularly, to keep everything in good working order and in the case of gasoline sets, to avoid fuel varnishing, which can affect performance, if the generator is stored for an extended time. See page 10, for more information about this important topic.

Managing Loads and Understanding Battery Charging – see pages 11-12 for an explanation of why these are important as well.

Cummins Onan Web Sites

CumminsOnan.com is the official online home for all Cummins Onan products. Visit CumminsOnan.com to learn more about our full line of RV generators for motorhomes and trailers as well as portable generators for the home or campground. You can also view operator manuals online or find the dealer nearest you with our sales and service locator.

Check it out today at www.cumminsonan.com.

Green Label Parts are available at most Cummins Onan dealer or distributor locations. If parts are not available locally or if it is more convenient, you can shop online at the factory store.

Maintenance parts and manuals are available for most RV Generator models and include the following:

- Oil Filters
- Oil Filter Wrench
- Air Filters
- Fuel Filters
- Spark Plugs
- Plug Wires
- Glow Plugs
- Tune-Up Kits

Manuals - Operator, Parts, Installation and Service

To order your parts and manuals online visit www.cumminsonanstore.com.

Funroads.com is the RVer's source for recreational vehicle travel ideas, buying RV parts, accessories and supplies, motorhome service, and RV classifieds, loans and insurance. Funroads.com is also home of the Coach Care RV Service Centers the only nationwide bumper-to-bumper service network exclusively for motor homes. For chassis work, maintenance, appliance repairs and everything in between, Coach Care provides professional service in a friendly, no-hassle atmosphere. Visit Funroads.com to learn more about Coach Care and to find the location nearest you.

Visit the RV rally that never ends, www.funroads.com.

III: Determining Which Cummins Onan Generator Model You Own

For the 2008 model year, Cummins Onan RV generator models will be receiving new model names, to more closely align them with the Cummins model descriptor standard. Two new model identifiers – Quiet Gas(QG) and Quiet Diesel(QD) will be introduced. Each of these will identify which type of fuel the generator runs on and will be followed by the unit's kilowatt rating. For example, the MicroQuiet 4000 gasoline model will now be called the QG4000, the Quiet Diesel 8000 will now be called the QD8000 and so on. Following is a chart of the old and new identifiers for Cummins Onan RV generators:

Prior Brand Family	Prior Brand Name	New Brand Family	New Brand Name
Quiet Diesel Generators	Quiet Diesel 5500	Quiet Diesel Series	RV QD 5000
Quiet Diesel Generators	Quiet Diesel 6000	Quiet Diesel Series	RV QD 6000
Quiet Diesel Generators	Quiet Diesel 7500	Quiet Diesel Series	RV QD 7500
Quiet Diesel Generators	Quiet Diesel 8000	Quiet Diesel Series	RV QD 8000
Quiet Diesel Generators	Quiet Diesel 10000	Quiet Diesel Series	RV QD 10000
Quiet Diesel Generators	Quiet Diesel 12500	Quiet Diesel Series	RV QD 12500
Marquis Gold Generators	Marquis Gold 5500	Quiet Gasoline Series	RV QG 5500
Marquis Gold Generators	Marquis Gold 5500	Quiet Gasoline Series	RV QG 5500 EVAP
Marquis Gold Generators	Marquis Gold 5500LP	Quiet Gasoline Series	RV QG 5500 LP
Marquis Gold Generators	Marquis Gold 6500LP	Quiet Gasoline Series	RV QG 6500 LP
Marquis Gold Generators	Marquis Gold 7000	Quiet Gasoline Series	RV QG 7000
Marquis Gold Generators	Marquis Gold 7000EVAP	Quiet Gasoline Series	RV QG 7000 EVAP
Marquis Platinum Generators	Marquis Platinum 5500	Quiet Gasoline Series	RV QG 5500 EFI
Marquis Platinum Generators	Marquis Platinum 7000	Quiet Gasoline Series	RV QG 7000 EFI
MicroLite/MicroQuiet Generators	MicroLite 2500 LP	Quiet Gasoline Series	RV QG 2500 LP
MicroLite/MicroQuiet Generators	MicroLite 2800	Quiet Gasoline Series	RV QG 2800 EVAP
MicroLite/MicroQuiet Generators	MicroQuiet 4000	Quiet Gasoline Series	RV QG 4000

Prior Brand Family	Prior Brand Name	New Brand Family	New Brand Name
MicroLite/MicroQuiet Generators	MicroQuiet 4000EVAP	Quiet Gasoline Series	RV QG 4000 EVAP
Camp Power Generators	Camp Power 2500 LP	Quiet Gasoline Series	RV QG 2500 LP Remote Muffler
Camp Power Generators	Camp Power 2800	Quiet Gasoline Series	RV QG 2800 Remote Muffler
Camp Power Generators	Camp Power 3600 LP	Quiet Gasoline Series	RV QG 3600 LP Remote Muffler
Camp Power Generators	Camp Power 4000	Quiet Gasoline Series	RV QG 4000 Remote Muffler
Juice Box (Gear Box)	Juice Box 3600 LP	Juice Box Series	Juice Box 3600 LP
Juice Box (Gear Box)	Juice Box 4000 LP	Juice Box Series	Juice Box 4000

Nameplate/Description

Each Cummins Onan generator also has a spec number description, which is shown on the serial number tag attached to the generator. Here is a representation of the tag on a QG4000.

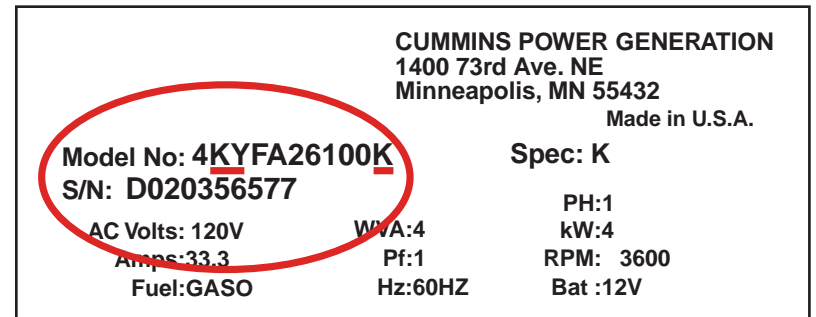

Note the highlighted letter code, in this case K, which denoted the specification type of the particular generator, which can then be referred to as a spec K. This information is helpful in determining which parts to use if service is needed at some point in the future. Note your new Cummins Onan model identifier and spec code in the boxes below. Then if you need to obtain service parts in the future, you'll have an easily accessible record to speed the process.

Model/Serial Number Record

When contacting a Cummins Onan Authorized RV Service and Parts Dealer for service, maintenance or parts questions, always refer to the complete model, spec and serial number of your Cummins Onan RV generator. These numbers are printed on your Cummins Onan generator unit nameplate. Write them in below for easy reference.

Model No:

Serial No:



IV: RV Generator Operation

Load Management Basics

To understand how battery chargers, automatic generator start systems and other baseloads affect your generator, you need to be aware of three things:

- 1) Your generator's power capability
- 2) How to manage electrical loads
- 3) Battery charging times

Determining Your Generator's Power Capability

To determine what your generator can power, use the chart on the opposite page to estimate the total combined watts of all the appliances, lamps, battery chargers, air conditioners and other electrical products you typically use at the same time. (All electrical appliances and lights are labeled with their power requirements expressed in watts or amps). You can use any number of appliances simultaneously, as long as their combined wattage doesn't exceed the electrical output of your Cummins Onan generator or your RV's circuit breaker rating.

Common Power Requirements		
Appliances	Average Required Wattage	Amps
Air Compressor (1hp)	1500-2000	9-20
Air Conditioner	1400-2400	9-20
Battery Charger	Up to 3000	6-28
Blender	600	5.5
Broiler	1350	12
Broom/Vacuum	200-500	1.5-4
Coffeepot	550-1000	4-8
Compact Disc Player & Speakers	50-100	0.5-0.9
Computer	50-100	0.5-0.9
Converter	500-1000	4-8
Curling Iron	20-50	0.2-0.5
Dishwasher	1400	12
Drill	250-750	2-6
Electric Blanket	50-200	0.5-1.5
Fan	25-100	0.2-0.9
Frying Pan/Wok	1000-1350	8-11
Hair Dryer	350-1500	3-13
Iron	500-1200	4-10
Lightbulbs	40-100 ea.	0.36-0.9
Microwave/Convection Oven	700-1500	6-13
Radio	50-200	0.5-1.5
Refrigerator	400-1000	3-8
Space Heater	1000-1500	8-13
Stove (per element)	350-1000	3-8
Television	200-600	1.5-4
Toaster	750-1200	6.5-10
VCR	150-200	1.15
Washer/Dryer	2000-2250	16
Water Heater	1000-1500	8-13
Water Pump	500-600	4-5

Operating Motor Driven Appliances

When using an appliance with a motor, turn it on and let it reach normal running speed before starting other appliances. Air conditioners, like all electric motors, can draw up to three times more power during the first few seconds of start up than during normal operation. While this is common for all electric motors, it is especially true for air conditioners if the compressor tries to start against built-up high pressure in its refrigeration system.

Air Conditioner “Short-Cycling”

When an air conditioner runs, the compressor builds refrigerant pressure. When the compressor is then shut off, either manually or by satisfying thermostat demand, it must stay off for some period of time, usually 3-4 minutes, to allow pressure in the system to equalize before safely restarted. Trying to restart the air conditioner compressor before pressure equalizes is known as “short-cycling”.

A “short-cycled” air conditioner could 1) trip the air conditioner circuit breaker; 2) shut down the generator due to overload; or 3) trip the air conditioner due to thermal overload. The air conditioner thermal overload will reset itself after the compressor cools. Typically, you cannot manually reset.

Some, but not all, RV air conditioner thermostats have built-in time delays to prevent short-cycling. Short-cycling occurs in some RVs when the thermostat is mounted so that cold air blows directly on it. If this happens, the thermostat shuts the compressor off before the cabin has cooled, but quickly warms back up and signals the compressor to restart before refrigerant pressure equalizes. In this case, direct the flow of air from the air conditioner away from the thermostat or relocate the thermostat. You can prevent air conditioner short-cycling by always ensuring the air conditioner rests for 3-4 minutes after the compressor shuts off before trying to restart it.

Effects Of High Altitude And Extreme Temperatures

If you travel at high altitudes or in extreme temperatures, your generator can lose power. In such lower-density air conditions, you can't operate as many electrical devices as you could under normal operating conditions.

Power decreases 3.5% for each 1,000 feet above an altitude of 500 feet. For example, to operate at 4,500 feet (4,000 feet above rated generator altitude) multiply $3.5\% \times 4$ (4,000 ft) = 14% power loss. Then multiply $.14 \times$ your generator's power rating: 4,000 watts $\times .14$ = a loss of 560 watts at that altitude.

Power decreases in extreme temperatures by 1% for each 10° F (5.5° C) above 85° F (29.4°C).

NOTE: The carburetor on a non-EFI gasoline generator may require adjustment at high altitudes. (See your Operator's Manual or your Cummins Onan Authorized RV Service and Parts Dealer.)

Starting And Stopping Procedures

Your Cummins Onan generator can be started and stopped from the integral control panel on the generator, or from the optional remote control panel inside the vehicle if your RV is so equipped. Your Operator's Manual outlines the simple steps for starting and stopping. Remember to:

- Before starting the generator, turn off air conditioners and large electrical loads.
- Before starting in cold weather, turn off all appliances for best long-term performance.
- Prime by holding stop (all Quiet Diesels, Quiet Gas 3600-7000).
- To start - press and hold start at the control panel or at the set.
 - Quiet Diesel: auto pre-heat flash, then crank/start
 - Don't over-crank with no start
- Before turning on appliances, let the generator warm up for a few minutes.
- Turn off air conditioners and large electrical loads and allow the generator to run for 3-5 minutes before stopping, to allow the generator to cool down.

Breaking In Your New Generator

Your generator will perform better if you follow the break-in procedure recommended in the Operator's Manual. The break-in process typically involves running the generator at about 50 percent load for two hours, then at about 75 percent load for two hours, then letting it cool down. You should change the engine crankcase oil after the first 20 hours of operation, and every 100 to 150 hours thereafter. (See the Maintenance Chart on page 23-24 for specific intervals.)

Exercising Your Generator

It may seem surprising that “not” using a machine could cause performance problems, but with RV generators that's exactly the case. Regular “exercise” is an important part of keeping your generator healthy. Lack of exercise can cause moisture build-up and fuel system degradation that make it run poorly. In fact, in as little as 30 days, the fuel in gasoline-powered generators can begin to gum and varnish the fuel system. Fuel varnishing results in hard starting and surging. (A surging generator never settles at a stable operating speed.)

To prevent such problems, it is recommended to run gasoline generators at a minimum of 50 percent capacity (2000-watts, or one air conditioner for a 4000-watt set) for two hours once every four weeks. This is necessary to help keep moving parts lubricated, expel moisture and control fuel varnishing in the carburetor. A long two-hour exercise period is preferable to several short periods. While traveling, this can be accomplished by running the air conditioning. If you own a diesel generator, regular exercising can help reduce internal condensation and helps keep seals lubricated.

Managing Electrical Loads

If you try to operate too many things at once, you'll "overload" the generator. Your lights will flicker or the circuit breakers on the generator or the main electrical panel will trip open, stopping the flow of power.

Battery chargers replenish power drained from starting the engine and generator or appliances operating on inverter power such as a microwave, refrigerator, mechanical slide out or pump.

Battery charging can overload your generator and you may not realize this is happening because the charging starts automatically.

Typical "invisible" charging loads:

- During start-up, air conditioners need "reserve" power and can draw 3-4 times the typical 1400-2400 watts needed to run. Too much baseload can prevent air conditioners from starting.
- Battery chargers are activated automatically and can draw a large load (up to 3000 watts). Manage your electrical loads by adjusting battery charge rates to best suit your needs. Consult your inverter/charger manual or manufacturer.
- If you have an automatic generator stop/start system, learn how to control it. Consult your inverter/charger manual or manufacturer for adjustment procedures. Adjust battery charge rates to best suit your total electrical needs. This system is not part of a Cummins Onan generator.

NOTE: The generator will continue to run after a circuit breaker trips. Turn off all appliances before resetting the breaker. If the breaker trips again with all electrical loads off, you may have a short circuit in your wiring. Turn off the generator and contact a qualified electrician.

Example: Dashed box below shows that a 2000 watt inverter running at 100A battery charge capacity creates the same load as an 11000 BTU air conditioner plus a microwave oven.

Battery Charging Loads				
Inverter/Converter Size (watts)	Battery Charger Max Output (14vdc)	Amps Required From Generator (at 120VAC)	Watts	Equivalent Appliance Load Example
1000	50 Amps	12A	1440	Hi-efficiency AC or microwave
1500	75 Amps	16A	1920	Hi-efficiency AC plus microwave
2000	100 Amps	21A	2520	11000 AC plus microwave
2500	120 Amps	26A	3120	13500 AC plus microwave
3000	140 Amps	28A	3360	11000 AC plus 13500 AC

Understanding Battery Charging Times

In addition to understanding battery charging loads, it is important to know that battery charging takes time. The chart below shows how long a 100A charger must run before reaching 100% battery charge.

Example: Dashed box below shows that when using a 100A battery charger, a 600A/hr battery bank at 60% charge level must be charged for 4.2 hours before it is fully charged.

Conditions that increase battery charge times:

- If too many DC loads like pumps and fans are operating, the charger may never catch up to the drain on the batteries. The Battery Charging Times Chart assumes no other DC loads are operating.
- 120V air conditioning loads powered through the inverter lengthen charge time due to power sharing. Consult your inverter/charger's manufacturer manual for charge rate control.
- Poor batteries, cables, or connections extend battery charging times.

Manage electrical loads to get the most performance from your generator and electrical system.

If you need help, ask your RV dealer for training on how to operate auto-starting systems as well as how to adjust battery charger output. If the dealer can't help, contact the inverter/charger or control manufacturer.

Battery Charging Times					
Battery Bank size (Amp Hours)	Hours that a 100A battery charger must run to reach float rate starting from this % of battery charge.				
	80%	60%	40%	20%	0% (11 VDC)
100	0.3	0.7	1	1.3	1.6
200	0.6	1.4	2	2.6	3.2
400	1.2	2.8	4	5.2	6.4
600	1.8	4.2	6	7.8	9.6
800	2.4	5.6	8	10.4	12.8
1000	3.0	7.0	10	13.0	16.0
1200	3.6	8.4	12	15.6	19.2
1500	4.5	10.5	15	19.5	24.0

NOTE: Table is for a 100A battery charger (typical 2000 watt inverter) pulling 21A (2520 watts) from generator, depending on battery bank size.

Preventing Surging

The electrical supply (voltage and frequency) for any appliance must remain within very close limits for it to operate properly. Changes in the electrical supply (called surging) can damage the appliances in your RV. Proper care of your generator will enable it to supply a stable power source and prevent surging.

RV generator engine speed is controlled with a governing system. Most generators have a mechanical governor, although the latest Cummins Onan EFI generators and Quiet Diesel generators use an electronic governor. Without a governor, engine speed simply drops as appliances are turned on, until the generator finally stops running. With a governor, the carburetor throttle opens or the EFI system adjusts to compensate for the increased load and thus maintains a constant speed.

The governor works in careful balance with the generator engine, fuel system, regulator and generator. If the balance is upset, surging may result.

A variety of things can cause surging, including an inadequate fuel supply, lack of exercise and poor maintenance. (See the Troubleshooting Guide on page 29.)

Tips To Help Prevent Surging

Ensure adequate generator fuel supply. Fuel is drawn from a remote fuel tank, which in many cases is usually the vehicle's main fuel tank. Typically the generator's fuel pickup only extends 3/4 of the way to the bottom of the tank — to prevent you from completely draining the tank and finding yourself stranded at your campsite! In other words: fuel in the tank does not guarantee fuel to your generator, especially if you have two fuel tanks in your vehicle. A cracked, leaking fuel line or a defective fuel pump can also cause inadequate fuel supply to the generator. Contact your local Cummins Onan Authorized RV Service and Parts Dealer to diagnose fuel supply problems.

Follow the generator exercise recommendations or the out-of-service protection recommendations outlined in your Operator's Manual. Gum and varnish from stale fuel can plug small carburetor passages causing a lean fuel mixture and surging. Treat the fuel system with Green Label Parts Premium Fuel System Cleaner in the clean-up mode ratios. Contact your local Cummins Onan RV Service and Parts Dealer to have the carburetor cleaned and adjusted or replaced if the problem persists.

Adjustment should be done on gasoline or LP model's carburetor, choke, and governor by your local Cummins Onan Authorized RV Service and Parts Dealer, who has specialized instruments made specifically for this job.

Make sure ignition system components are in good condition.

On carbureted models with a manual pre-heater control lever, set the carburetor air pre-heater in the proper position for the temperature and humidity at your location. For temperatures below 55° F and/or high humidity, set the selector in the winter position.

CAUTION: When operating electronic appliances (TVs, computers, VCRs, etc.) in your RV, it is important to use surge protectors to prevent power surges from damaging your equipment. Cummins Onan is not responsible for damage to sensitive electronic equipment.

Installed Cummins Onan Generators Are Exceptionally Quiet.

Noise Comparison Chart (in decibels*)

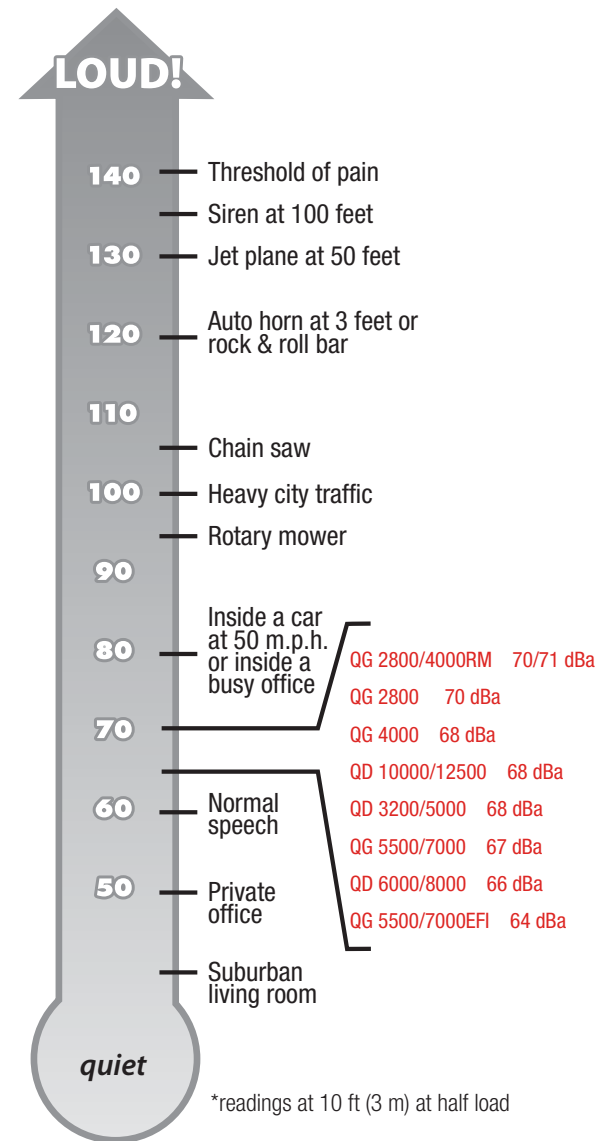



V: Frequently Asked Questions (FAQs)

Q: Can a generator charge my RV house battery?

A: Not directly. But a generator does provide power to operate your converter/charger, which charges batteries. Many diesel generators also have an alternator, which can charge batteries.

Q: Is it practical to power the roof air conditioner with my generator while traveling on the road?

A: Yes, that is what a generator is for, portable electrical power. In fact, it can help you economize on your vehicle fuel because the generator uses less fuel. Plus, it gives you an opportunity to exercise your generator. Any appliance that can be run in a stationary position can also be powered while driving.

Q: Can I run my generator for extra power while I'm hooked up to shore power at a campground?

A: Only if the RV manufacturer has supplied a separate circuit for a second air conditioner. However, in most RVs with two air conditioners, only one will operate while plugged into commercial shore power. By the NFPA code you cannot connect both power sources, generator power and commercial shore power, together. RV electrical systems are designed to separate these two power sources. However, with your comfort and needs in mind, your RV manufacturer may have wired the RV to allow you to power your second air conditioner with your RV generator. Check your vehicle's operator manual.

Q: Why does a breaker trip and the rear air conditioner not work when I turn it on while the generator is running?

A: RVs with two air conditioners typically have a 20-amp circuit breaker for the rear air conditioner and a 30-amp breaker for all other loads (including the front air conditioner). The RV may be wired with the two circuits reversed, causing the breaker to trip. The generator connections and wiring should be checked by an authorized service location.

Q: Is generator power clean enough to run a computer?

A: Yes, with Cummins Onan generators this is no problem. The set should be turned on and warmed up before turning on the computer. The normal precautions for home use should be followed for RV use as well.

Q: Can I operate an air conditioner and microwave at the same time?

A: Although this is possible in lower temperatures or altitudes or with high efficiency AC's, Cummins Onan 2500 and 2800 watt generators will probably be overloaded when the AC cycles off and on with the microwave running. Load shedding devices are available that automatically turn off the AC when the microwave starts and then restarts it when power is available again. All other Cummins Onan generators can operate both of these appliances at the same time.

Q: Will high efficiency (power saver) air conditioners provide more reserve power?

A: YES. High efficiency AC's use 30% less power and are easier to start. That means more power is available for use in the RV or for better fuel economy. High efficiency AC's also have higher cooling output than comparable standard AC's.

Q: What happens if I "short-cycle" my air conditioner?

A: Short cycling refers to stopping and restarting the air conditioner compressor before the refrigerant pressure has enough time to equalize. If this happens, one of several things can occur: a circuit breaker may trip, either on the generator or at the breaker panel; the generator engine may stall; the AC compressor may trip its overload. AC compressors should remain off for at least 3 minutes before being restarted.

Q: Will increasing the speed (accelerating the RPM) on my generator provide more power potential?

A: No, and it may damage your generator and appliances.

Q: Can I run an RV generator in a National Park?

A: Yes. Cummins Onan installed generators are quieter than the National Park sound level requirements. (During allowable hours of use.)

Q: What is carburetor icing? What conditions cause it? How can it be prevented?

A: Carburetor icing occurs in damp, cool outside conditions, causing rough operation, stalling and throttle sticking. If your generator is equipped with a summer/winter lever, operate the generator in the "winter" position in humid temperatures of 55°F or less. This will pre-heat the intake air so ice won't form in the carburetor.

Q: Once the generator is started, should it continue to run for a certain length of time?

A: Ideally, Cummins Onan generators should run for a minimum of 30 minutes to give them a chance to warm up. Once warmed up, running your generator for five-minute intervals should be fine. But remember to turn on some appliances so the generator works while it's running. Running it for more than 30 minutes at no load only burns fuel unnecessarily and adds costly maintenance.

Q: How are “will-fit” generator replacement parts different from Green Label Parts™?

A: Cummins Onan genuine Green Label Parts™ are tested and designed specifically for RV applications. Will-fit parts and gaskets can be the correct shape, but because of inadequate design, the wrong material, or poor quality, they could cause premature failure, leakage or performance problems. Use of some non-Cummins Onan replacement engine parts may affect the unit's emissions certification, and damage caused by use of oil and air filters other than Green Label Parts is not covered under your generator warranty.

Q: How often should I perform maintenance on my generator? Will doing it myself affect my warranty?

A: The Operator's Manual that accompanies each generator outlines proper maintenance procedures and intervals. If you follow the procedures correctly, warranty coverage remains intact. However, proper maintenance will obviously affect warranty coverage. For more information, see the Maintenance Intervals charts on page 23.

Q: How frequently should I change oil if I won't be using the generator for several months?

A: Typically just like a car, change oil for seasonal temperature changes. For long storage, see your Operator's Manual for extended out-of-service protection.

Q: Should I use straight 30-weight oil or is the multi-viscosity oil I use in my vehicle okay?

A: For best generator performance, we recommend you use Onamax™, the Green Label Parts oil specifically formulated for RV generators. However, you can use the same oil you use in your vehicle engine provided it meets or exceeds SG/CE API specifications. To get you off to a good start, all new Cummins Onan generators are factory prepared with Onamax 15W-40 oil.

Q: Will high-octane gasoline reduce the amount of fuel varnish?

A: No, because varnish is a form of fuel degradation that is not a function of octane level. Rather, it is a function of fuel quality, age and additive treatment. High-octane fuel without stabilizer additive will oxidize or varnish at a faster rate than fuel treated with a fuel stabilizer.

Q: When I'm checking my oil, does the dipstick need to be screwed in all the way?

A: In order to get the correct oil level reading, the dipstick must be screwed in completely on all models with a screw-type dipstick, except for the RV QG 2800/2500 & RV QG 2800/2500 RM models; it sits on top of the fill tube. Make sure the vehicle is level when checking oil level.

Q: Do diesel generators need exercising like gasoline generators?

A: Yes, it helps lubricate the seals and engine components and keeps carbon from building up. Regular exercise also heats up the generator windings and removes or expels excess moisture. In sets equipped with brushes, exercising helps prevent corrosion build up on the slip rings.

Q: How do I keep mice/rodents out of my generator during storage?

A: Use rodent prevention techniques around the generator/compartments just as you would with any other area of your RV.

Q: Can I use the RV QG 4000 RM, RV QG 4000 or Emerald 4000 generator to run two air conditioners?

A: No.

Q: Will the starter motor continue to be engaged if the start button is held too long?

A: All Cummins Onan generators are equipped with a start disconnect feature which will not allow the starter to crank once the generator is producing electrical output.

Q: Why don't I have as much power as I think I should?

A: Battery chargers run as “invisible” loads, and can draw as much power as two air conditioners, depending on size. This can continue for several hours, depending on battery charger and battery bank size. (See the Battery Management section on page 12 for more information.)

LP Generators

Q: Should I get an LP or a diesel generator for my diesel motorhome? What are the differences?

A: Each fuel option has its own advantages. LP generators generally have a lower initial cost than diesel units. Plus, they're smaller and lighter weight, allowing for more flexibility in the floor plan of large RVs. LP generators also have less exhaust fume smell. Diesel generators have a much longer engine life. They consume less fuel, and diesel fuel usually costs less than LP, which brings additional savings. A diesel generator gives you a common fuel system, and the convenience of operating your generator from the vehicle's main fuel supply. The generator best for you depends on how you use it and your own personal preferences.

Q: How is LP fuel supplied to my generator?

A: LP fuel is stored in the fuel tank in liquid form with some vapor at the top of the tank at relatively high pressure. The pressure in the tank is determined by the ambient (outdoor) temperature. The higher the temperature the higher the pressure. Ambient heat vaporizes fuel until the pressure won't allow any more liquid to vaporize. The tank pressure will be about 200 psi at 110°F, 70 psi at 40°F, and 0 psi at -40°F (40°C).

In order for the fuel to be burned at a controlled rate in the generator (or any other appliance) it must be converted to a vapor form and supplied at a controlled pressure.

LP fuel systems for many Cummins Onan generators are available in two forms, vapor withdrawal and liquid withdrawal.

Q: What is the difference between LP Vapor and LP Liquid Fuel Systems?

A: LP Vapor Withdrawal — With a vapor withdrawal system, the LP fuel is vaporized in the fuel tank by heat input from the environment. The pressure is reduced to about 11-inches of water column (0.4 psi) at the tank outlet with a regulator. The vaporized LP fuel flows to the demand regulator on the generator, which reduces the pressure before it enters the carburetor.

LP Liquid Withdrawal — With a liquid withdrawal system, liquid LP fuel flows at tank pressure to the generator where heat from the generator converts the fuel from liquid to vapor form. A two-stage regulator reduces fuel pressure before it enters the carburetor.

Q: What are the advantages of each type of LP fuel system?

A: LP Vapor Withdrawal

- Simpler system for the generator set.
- Same low-pressure vapor system as other appliances.

LP Liquid Withdrawal

- Better operation in cold temperatures.
- Complete vaporization pressure regulation system is on the generator from the factory.

Q: Can LP fuel plug up the regulator?

A: The most common contaminants found in LP fuel are the oils from the LP pumping facility. The oil is removed from LP fuel at the location the fuel vaporizes. In liquid withdrawal LP fuel systems, this occurs in the regulator. Oil contaminants can then clog the regulator. The Cummins Onan QG models' liquid withdrawal LP fuel systems provide a drain for oil removal. See your Cummins Onan Authorized RV Service and Parts Dealer for assistance.

External Muffler Generators

Q: Is the muffler included on or with the RV QG RM generator?

A: No. Required muffler kits are available for each RV QG RM. See your distributor for more information on proper application for each kit.

Q: How many appliances can I operate with my RV QG RM 2800 or RV QG RM 2500 LP generator?

A: The RV QG RM 2800 can run a 13500 BTU air conditioner with 600-watts of power in reserve. In most trailers and truck campers, that is enough reserve to operate the DC converter (for TV, lights, fans, battery charger) in addition to the air conditioner. The 2500 LP model has slightly less reserve but still enough power for an air conditioner plus converter loads. With the AC off, both RV QG RM generators can operate any mix of standard RV appliances (i.e. microwave, coffee maker, hairdryer, etc.) up to the rated capacity.

Electronic Fuel Injection (EFI) Generators

Q: How reliable is the technology for electronic fuel injection? Will I have more problems?

A: No, you won't have more problems. Actually, you'll have less. The EFI technology used in our RV QG models is the same technology used in the automotive industry for over 10 years.

Q: Should I worry about gumming of the fuel system with my EFI generator?

A: No. Your EFI generator minimizes fuel system gumming. This will minimize maintenance and service requirements, and make storage of your RV much simpler.

Q: Does a generator with EFI start better?

A: The RV QG generator is much faster and more reliable in both hot and cold starting. This will result in fewer start failures.

Q: Do I have to adjust for altitude and temperature with EFI?

A: No, the RV QG EFI generator has automatic altitude and temperature compensation.

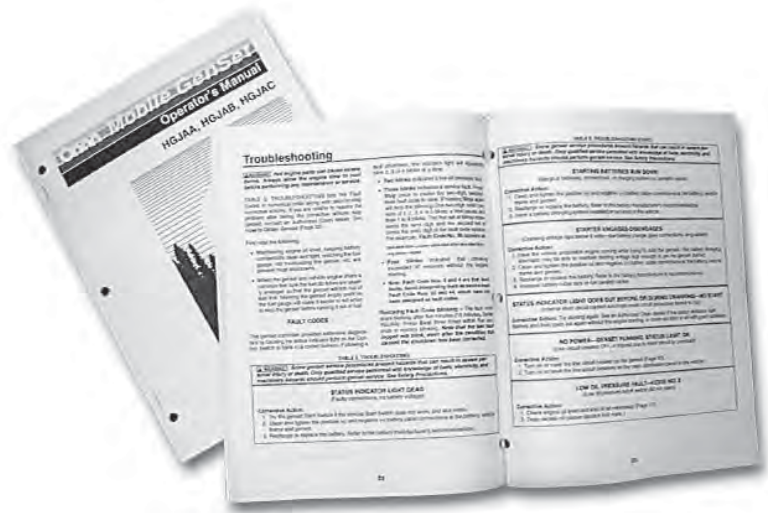

- Maintenance charts are printed in all Operator's Manuals.
- Check your generator exhaust system each time you start the generator. Make sure it doesn't leak and that it extends beyond the vehicle's perimeter.
- Refer to manual for service intervals for injectors and valve adjustments that typically are recommended at 500-1,000 hours.

VI: Generator Care & Maintenance

A Cummins Onan RV generator is an investment that can bring you many years of comfort and enjoyment. However, all generators require periodic maintenance for dependable, ongoing performance. Your Operator's Manual outlines the specific maintenance procedures and service intervals for your particular model. Take good care of your generator and it will take good care of you.

RV maintenance is performed according to the number of miles you travel. Similarly, generator maintenance is based on hours of running time. If your generator does not come equipped with an hour meter, install one, and place it in an easy-to-see location near the RV's electrical control panel so you can keep track of the hours your generator runs. The Cummins Onan deluxe remote control panel includes an hour meter. The following chart shows the recommended maintenance intervals for Cummins Onan generators. These are general guidelines only. Consult the Operator's Manual for procedures and maintenance intervals for a specific model. If you are unable to locate your Operator's Manual, many can be viewed online or purchased at Funroads.com.

RV Generator Manuals						
	Series	Spec Letter	Operators	Parts	Service	Installation
MicroQuiet	KY	A	981-0139	981-0246B	981-0503	981-0627
	KY	B-C	981-0139	981-0246B	981-0503	981-0607
	KY	D-H	981-0154	981-0246B	981-0503	981-0607
	KY	J	981-0159C	981-0246B	981-0530	981-0621
	KY	K	981-0159C	981-0246C	981-0530	981-0621
	KY	L	981-0159C	981-0246D	981-0530	981-0621
	KY Tracker	E-F	981-0155	981-0246B	981-0503	981-0611
Quiet Diesel 10000	HDCAA	A-B	981-0152C	981-0259C	981-0526D	981-0615C
Quiet Diesel 10000	HDCAA	C	981-0170	981-0259D	981-0526D	981-0637
Quiet Diesel 12500	HDCAB	A-B	981-0152C	981-0259C	981-0526D	981-0615C
Quiet Diesel 12500	HDCAB	C	981-0170	981-0259D	981-0526D	981-0637
Quiet Diesel 7500	HDKAJ	A-H	981-0161	981-0200D	981-0522B	981-0623
Quiet Diesel 8000	HDKAK	A-H	981-0161	981-0200D	981-0522B	981-0623
Quiet Diesel 5500	HDKBA	A	981-0166B	981-0271	981-0535	981-0633B
Quiet Diesel 5500	HDKBA	A-C	981-0166B	981-0271B	981-0535	981-0633B
Quiet Diesel 10000	HDKCA Kubota	A	981-0173	981-0277	981-0540	981-0640
Quiet Diesel 12500	HDKCB Kubota	A	981-0173	981-0277	981-0540	981-0640
Marquis Platinum	HGJAA	A-C	983-0101B	983-0201C	983-0501C	983-0600
Marquis Gold	HGJAB	A-C	983-0101B	983-0201C	983-0501C	983-0600
Emerald Advantage	HGJAC	A-C	983-0101B	983-0201C	983-0501C	983-0600
MicroLite	KV	A-B	981-0129	981-0238F	981-0506	981-0626
	KV	C-D	981-0136	981-0238F	981-0518D	981-0604
	KV	E-K	981-0153C	981-0238F	981-0518D	981-0604
	KVC	A-C	981-0158C	981-0238F	981-0518D	981-0620
Camp Power	KVD	A	981-0164B	981-0238F	981-0518D	981-0631B
	KYD	A-B	981-0169	981-0246D	981-0530	981-0636

General Generator Maintenance Intervals

Model	Service Intervals - Repeat Every							
	Mthly	50 Hrs	100 Hrs	150 Hrs	200 Hrs	250 Hrs	450 Hrs	500 Hrs
RV QG/RV QG RM (CAMP POWER™/MICROLITE™/ MICROQUIET™)								
Clean & Check Battery & Connections	X (3)							
Clean Arrester		X (5)						
Change Oil				X (1-4)				
Change Air Filter				X (2,4,5)				
Replace Spark Plugs								X (5)
Change Fuel Filter							X (5)	
Schedule Cummins Onan Service Center Tune-Up							X (6)	
RV QG/RV QG EFI (EMERALD ADVANTAGE™/MARQUIS PLATINUM™/MARQUIS GOLD™)								
Clean & Check Battery & Connections	X (3)							
Clean Spark Arrester		X (5)						
Change Oil/Oil Filter				X (1-4)				
Change Air Filter								X (2)
Replace Spark Plugs							X (5)	
Change Fuel Filter							X (5,6)	
Schedule Cummins Onan Service Center Tune-Up							X (6)	
RV QG (EMERALD™/MARQUIS™)								
Clean & Check Battery & Connections	X (3)							
Clean Spark Arrester		X (5)						
Change Oil/Oil Filter				X (2-4,7)				
Change Air Filter				X (2,4,5)				
Replace Spark Plugs								X (4,5)
Change Fuel Filter								X (5)

General Generator Maintenance Intervals

Model	Service Intervals - Repeat Every							
	Mthly	50 Hrs	100 Hrs	150 Hrs	200 Hrs	250 Hrs	450 Hrs	500 Hrs
Schedule Cummins Onan Service Center Tune-Up								
								X (6)
RV QD (DIESEL)								
Clean & Check Battery & Connections	X (3)							
Clean Spark Arrester				X (5)				
Change Oil/Oil Filter – All Except Quiet Diesel™		X (1-4)	X (2-4)					
Change Oil/Oil Filter – Quiet Diesel 5500		X (1-4)		X (2-4)				
Change Oil/Oil Filter – Quiet Diesel 7500/8000		X (1-4)		X (2-4)				
Change Oil/Oil Filter – Quiet Diesel 10000/12500	X (1-4)				X (2-4)			
Change Air Filter								X (2,5)
Change Fuel Filter – All Except Quiet Diesel						X (5)		
Change Fuel Filter – Quiet Diesel								X (5)
Schedule Cummins Onan Service Center Tune-Up*								X (5,6)

- 1 As a part of engine break-in, change the engine oil after the first 20-50 hours of operation.
 - 2 Perform more often when operating in dusty environments.
 - 3 Perform more often when operating in hot weather.
 - 4 Perform at least once a year.
 - 5 Perform sooner if engine performance deteriorates.
 - 6 Must be performed by a qualified mechanic (Cummins Onan Authorized RV Service and Parts Dealer).
 - 7 As a part of engine break-in, change the engine oil after the first 50 hours of operation.
- * Injector check and clean or replace.

Note: Perform a general inspection and check oil daily per maintenance schedule in Operator's Manual.

Do's And Don'ts For Better Generator Performance

The Do's:

- DO keep your generator clean by wiping it periodically with a clean cloth.
- DO turn off all appliances in cold weather before starting your generator, for best long-term performance.
- DO check owner's manual for periodic maintenance schedule.
- DO check the exhaust system regularly for damage or leaks. Make sure the exhaust pipe extends out at least one inch beyond the vehicle's perimeter.
- DO check the carburetor pre-heating selector (if one is installed) to ensure it's in the proper position for the surrounding climate. (See your Operator's Manual for proper settings, **Important:** This information applies only to carbureted models.)
- DO check the air filter periodically and clean it by tapping it on a flat surface. Never wash it in solvents or blow it out with an air hose.
- DO install a running hour meter so you know when scheduled maintenance service is due.
- DO exercise your generator regularly.
- DO purge the fuel system following the procedures listed in the Operator's Manual to maintain the LPG fuel filter.
- DO make sure that clean fuel, the most important factor for proper generator performance, is used on diesel models. Refer to the fuel recommendations covered on page 26.
- DO make sure each operator is familiar with the important safety precautions listed on pages 1-2.
- DO change your fuel filter. The fuel filter is an often forgotten part of any engine. Your generator has one too. It removes bits of debris from the fuel to prevent clogging the carburetor jets. Over time, the fuel filter collects enough material to become plugged, which restricts fuel flow and reduces the generator's power delivery. Be sure to change the fuel filter on a regular maintenance schedule.

The Don'ts:

- DON'T run the generator for long periods of time without using it to power appliances. It wastes fuel and may cause the engine to misfire.
- DON'T attempt to adjust the carburetor, governor, choke, etc., yourself. See your Cummins Onan Authorized RV Service and Parts Dealer for assistance.
- DON'T attempt to adjust EFI components on the generator if equipped.
- DON'T run your generator set with the door panel open.

Keep Your Generator Clean And Inspect It Regularly For Damage

Your RV generator is a hardworking device that lives in an unfriendly environment, typically in the underside of your RV. Dust and debris are a part of its daily life. Dust

can clog the intake system and reduce its engine's efficiency. Remember to replace air and oil filters regularly.

Over time, vibration from rough roads can loosen generator fasteners, while debris thrown up from the road can occasionally damage fuel lines and exhaust systems. It makes good sense to regularly inspect all these items. Do not use a water hose or high pressure car wash type sprayers on the generator. Light air pressure and a damp cloth are preferred.

Fuel Recommendations

Gasoline Generators — Treat the engine of your Cummins Onan generator to a good grade of regular unleaded gasoline and it'll purr in response. You can also use Gasohol (gasoline blended with alcohol) if it contains the correct additive mixture percentages:

- Ethanol Blend — Not more than 10% ethanol.
- Methanol Blend — Not more than 5% methanol and the fuel must also contain solvents and corrosion inhibitors.

NOTE: Fill up with fresh gas! The single most common service issue is stale or contaminated fuel. Always use fresh gas! The gas should not be more than 30 days old. Fuel stabilizer extends the life of your fuel. Stale fuel clean-out is not covered under your warranty.

LPG Generators — Use clean, HD-5 grade liquid propane gas in a mixture of at least 90% propane. Propane fuels other than HD-5 can contain more than 2.5 percent butane which can result in poor fuel vaporization and poor engine starting in outside temperatures below 32°F.

Diesel Generators — Use any of the following ASTM certified fuels for your quiet diesel:

ASTM-No.2-D	(ambient temperature greater than 23°F) (No. 2 Diesel)
or ASTM-1-D	(No. 1 Diesel)
No.2-DLS	(ambient temperature greater than 23°F)
No.1-D	(ambient temperature less than 23°F)
No.1-DLS	(ambient temperature less than 23°F)
B5 Biodiesel	(ambient temperature greater than 50°F)

Ensure the fuel selected for use has a minimum Cetane number of 45. No. 2-D or No.2-DLS diesel fuel gives the best economy and performance under most operating conditions. Use No. 1 diesel fuel when ambient temperatures are below 32°F and during long periods of light engine load. Use low sulfur or ultra low sulfur content fuel having a cloud point of at least 10°F below the lowest expected fuel temperature. Cloud point is the temperature at which wax crystals begin to form in diesel fuel.

Oil Recommendations

Use a premium, quality engine oil (such as OnaMax™ SAE-30 and SAE 15W-40) in the correct oil viscosity for your generator's typical operating temperature range to provide optimum engine service. Avoid mixing different grades or brands.

It's good practice to check the oil level daily or every 8 hours of operating time.

Keep the oil level as near as possible to full, but do not overfill. Overfilling may cause foaming and engine shutdown. Replace the cap tightly to prevent leakage. And if your generator has an oil filter, change it when you change the oil.

Do NOT check the oil level while the generator is running, because hot oil can be thrown out of the dipstick hole, causing severe burns.

Gasoline Engine Oil Quality – Use oil meeting any of the following API performance categories: SJ, SL or SM where SM is currently the highest quality available. Look for the “Energy Conserving” designation to optimize fuel economy.

Diesel Engine Oil Quality – Use oil meeting any of the following API performance categories: CF, CF-4, CG-4, CH-4, CI-4 or CJ-4 where CJ-4 is currently the highest quality available. The use of synthetic oil is not recommended. The use of oil meeting API performance category CF-4, CG-4, CH-4 or CI-4 while burning fuel with a sulfuric content greater than 0.5% or CJ-4 while burning fuel with a sulfuric content greater than 0.0015% is not recommended as oil service is negatively impacted.

Oil Viscosities – Use the following chart to select correct viscosity grades for expected ambient temperature range.

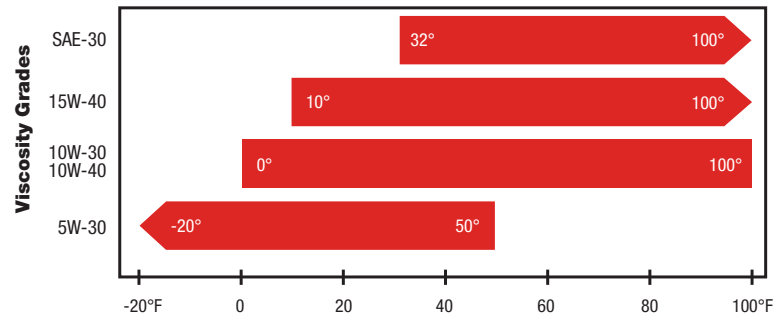

NOTE: Multi-grade oils (such as SAE 15W-40) are recommended for year-round use in Cummins Onan liquid-cooled engines, or as a good all-season oil for air-cooled engines.

NOTE: SAE-30 is the preferred summer grade for optimum oil consumption control in Cummins Onan air-cooled engines.

Coolant Recommendations

Quality of the coolant in your liquid cooled generator is an important factor in performance and service life. Always use a 50/50 mixture of ethylene glycol based antifreeze and water which should be mixed thoroughly before adding to the generator’s cooling system.

Water: Use clean, soft water from a tap, distilled water or pure rain in your mixtures. If hard water or other forms of natural water are used, your generator’s cooling system is more liable to oxidize, corrode and create deposits faster.

Antifreeze: The core components of ethylene glycol based antifreeze are acidic. Introduction of the cooling water creates alkaline properties that can rapidly corrode light metals. Be sure to select high quality antifreeze with corrosion inhibitors to prevent cooling system problems. Also – be sure to maintain the cooling system as use of antifreeze coolant for an extended period of time can result in increased corrosion.

Prevent Fuel Varnishing

If You Don’t Run A Tank Of Gasoline Each Month, You Could Be Risking The Performance Of Your RV Generator.

If you store your RV over the winter, or don’t operate it often enough to refuel the gas tank every month, you could develop a fuel varnishing problem in your generator engine.

Fuel varnishing is a gummy residue that clogs the generator carburetor and fuel pump. It’s caused by the deterioration of fuel that sits in the engine too long. And, it happens in a surprisingly short period of time. Depending on fuel quality and storage conditions, gasoline can deteriorate in as little as 30 days. As long as you refuel frequently with fresh gasoline, and exercise the unit regularly, fuel varnishing is less likely to occur. But if you leave the same gasoline in the tank for several months, you’re very likely to have problems.

Fuel varnishing affects many engines but it’s more noticeable in generators because the engines are smaller. Even the slightest decrease in efficiency has a big impact on performance. A generator with varnish buildup may start but run like it needs a tune-up. It surges, accelerating and decelerating, but rarely settles at a stable operating speed. In many of the gasoline powered units, engine speed directly affects generator voltage output and frequency. As speed increases/decreases, so does the voltage and frequency.

The only ways to prevent fuel varnishing are to treat the contents of the tank supplying fuel to the generator with a fuel preservative and to exercise the set. Cummins Power Generation has developed a fuel preservative and stabilizer, OnaFresh™, specifically formulated for Cummins Onan generators. We recommend adding this preservative to the fuel, especially on infrequently used RVs.

Emptying the tank won’t prevent fuel varnishing because a small amount of fuel always remains in the generator carburetor. If you plan to leave the tank empty, we recommend that you add a special mixture of fuel and a preservative before you run the tank dry so the residual fuel contains the preservative.

Once varnishing has occurred, adding a preservative won’t correct the problem.

You need to add a fuel cleaner, and manually scrub the varnish from the fuel system parts. Cummins Power Generation offers Premium Fuel System Cleaner for use with Cummins Onan generators

By understanding how to properly care for your RV generator and protect against fuel varnishing, you’ll enjoy better performance and longer, service-free operation.

It may seem strange that “not” using a product causes it to fail faster. With generators, though, that’s exactly the case.

Premium Fuel System Cleaner and OnaFresh, along with other Green Label Parts™ maintenance products can be found at your local Cummins Onan Authorized RV Service and Parts Dealer. To locate your nearest dealer, visit Funroads.com.

Important: Problems caused by fuel varnishing will not be covered under warranty.

Troubleshooting Guide

Under normal operating conditions, you can expect your Cummins Onan generator to perform reliably without problems. But if a problem does occur you may be able to isolate the cause by using the following troubleshooting chart.

If you cannot discover and correct the problem, make a note of your generator model and serial numbers and contact your local Cummins Onan Authorized RV Service and Parts Dealer. RV QD generators have a unique control system. Consult your RV QD Owner's Manual for troubleshooting information.

Trouble Shooting Guide		
Problem	Probable Cause	Solution
Fails To Crank	1. Low battery.	1. Check battery fluid level.
	2. Bad battery connection.	2. Clean & tighten all battery & cable connections.
	3. Blown fuse.	3. Replace fuse on control panel.
Cranks Slowly	1. Low battery.	1. Check battery fluid level.
	2. Bad battery connection.	2. Clean & tighten all battery & cable connections.
	3. Incorrect oil viscosity.	3. Replace with recommended viscosity oil.
	4. Load connected.	4. Disconnect load before starting.
Cranks But Won't Start	1. Fuel below generator pickup level in tank.	1. Add fuel.
	2. Fuel supply shutoff valve closed.	2. Fully open fuel supply valve.
	3. Carbon deposits on spark plug(s).	3. Remove spark plug(s) and replace.
	4. Low oil level.	4. Add oil.
Exhausting Black Smoke	1. Dirty air filter.	1. Replace air filter.
	2. Choke stuck or misadjusted.	2. Contact an Cummins Onan Authorized RV Service & Parts Dealer.
Unit Runs Then Stops, Or Stops When Driving Around A Corner	1. Low fuel level.	1. Add fuel.
	2. Low oil level.	2. Add oil.
	3. Excess oil.	3. Reduce engine oil level.
Unit Starts And Runs, Then Stops When The Start Switch Is Released	1. Low fluid levels.	1. Check & bring all fluids up to the appropriate levels.
	2. Possible overheating.	2. Check for blocked air flow or other possible causes of overheating.
	3. Other functional problem.	3. Contact an Cummins Onan Authorized RV Service & Parts Dealer.
	4. No AC output.	4. Contact an Cummins Onan Authorized RV Service & Parts Dealer.
Unit Runs Then Surges	1. Loose or worn spark plug leads.	1. Check spark plug leads at spark plug & ignition coil.
	2. Defective ignition coil, wiring, or control components.	2. Contact an Cummins Onan Authorized RV Service & Parts Dealer.
	3. Faulty spark plug.	3. Remove spark plug & clean or replace.
	4. Governor out of adjustment.	4. Contact an Cummins Onan Authorized RV Service & Parts Dealer.
	5. Combustion air pre-heat malfunction.	5. Contact an Cummins Onan Authorized RV Service & Parts Dealer.
	6. Carburetor icing.	6. Move carburetor pre-heater to the winter position.
	7. Carburetor varnishing.	7. Try fuel system cleaner and contact dealer if no change.
Circuit Breaker Trips	1. Overloaded circuit.	1. Turn-off some of the electrical load, and reset the circuit breaker.

WARNING! Incorrect troubleshooting procedures can result in risks of property damage, or death from fire, explosion, electrocution, and asphyxiation or being caught or hit by moving parts. **DO NOT ATTEMPT TROUBLESHOOTING** unless you are trained and experienced in electrical and mechanical maintenance.

Service Diagrams

RV QG 2800 RM

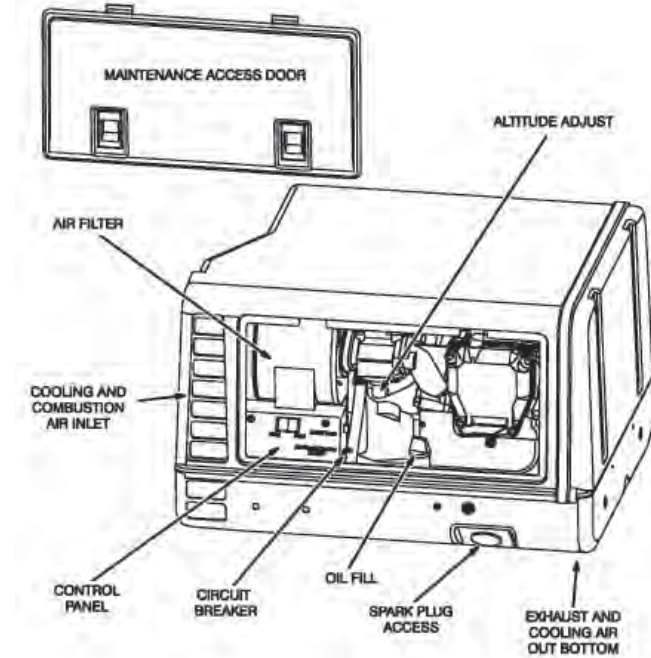

RV QG 2800

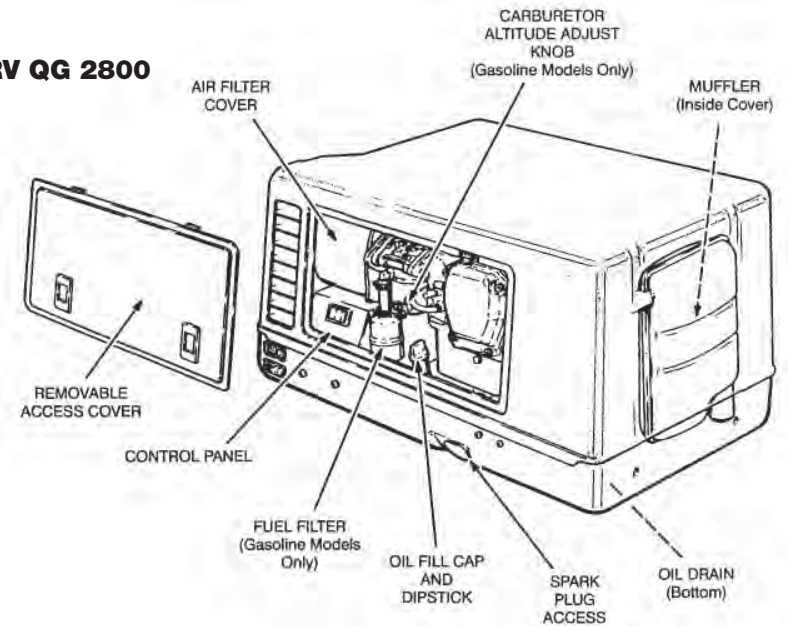

RV QG 4000 RM

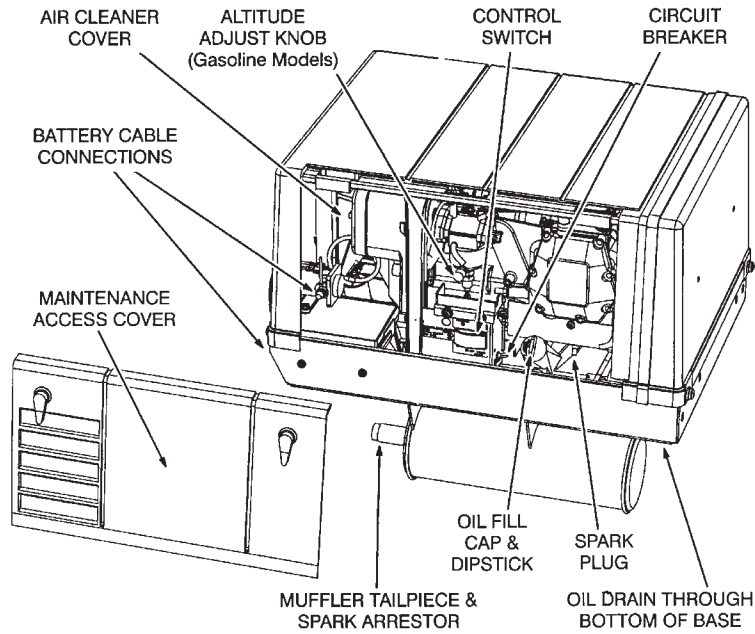

Emerald Advantage™

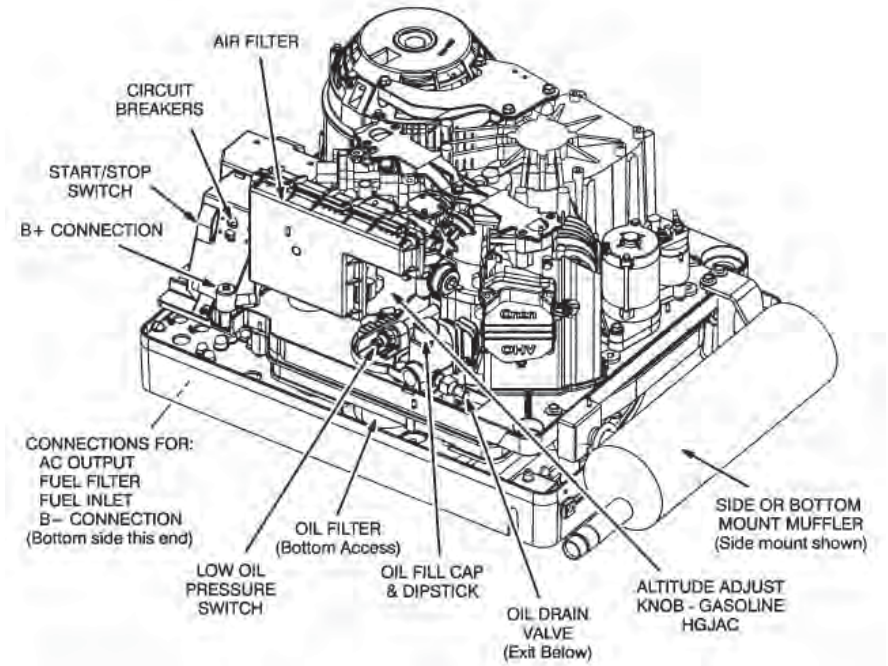

RV QG 4000

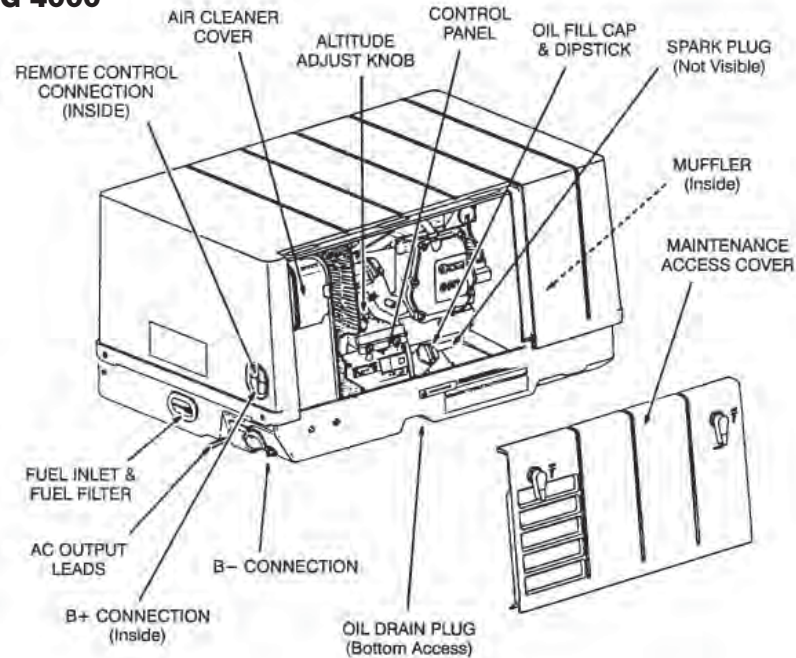

RV QG 5500/5500 EFI/7000/7000 EFI

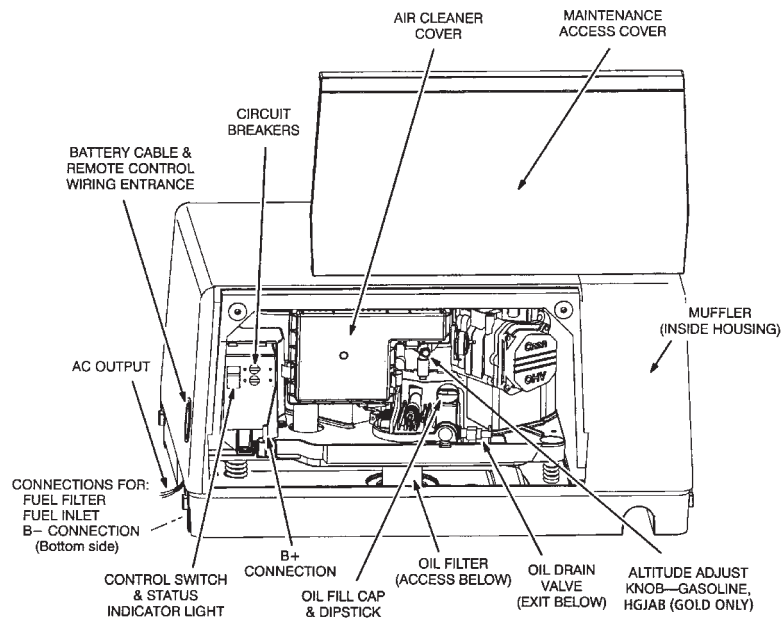

RV QD 3200

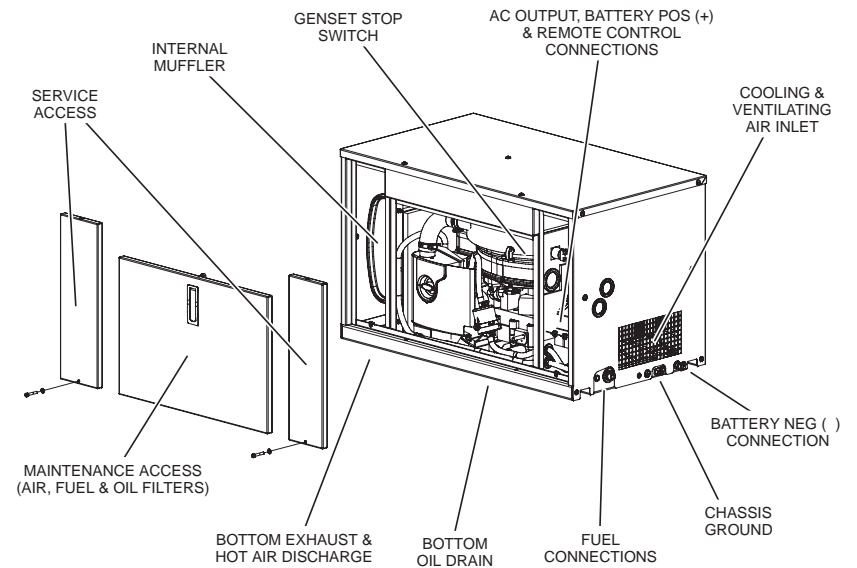

MARQUIS™

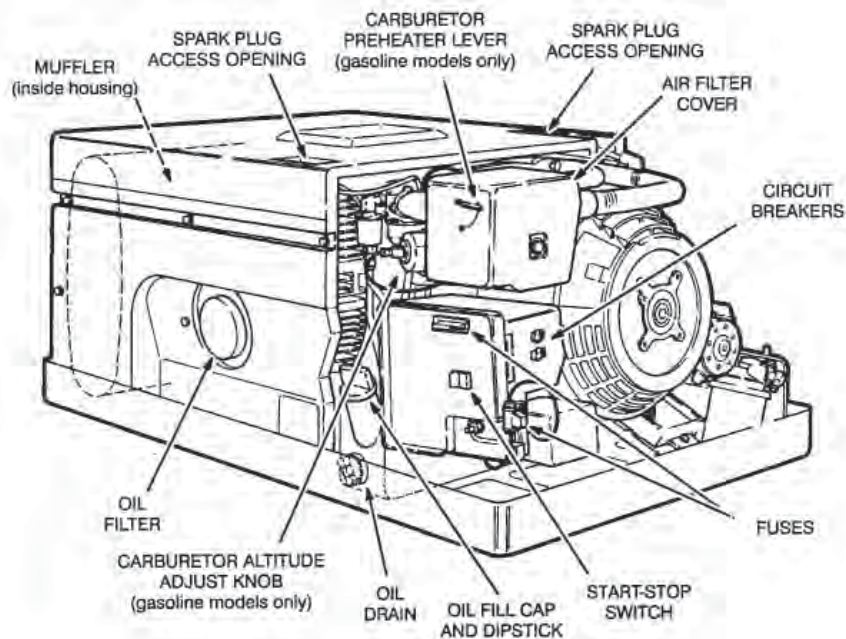

RV QD 5000

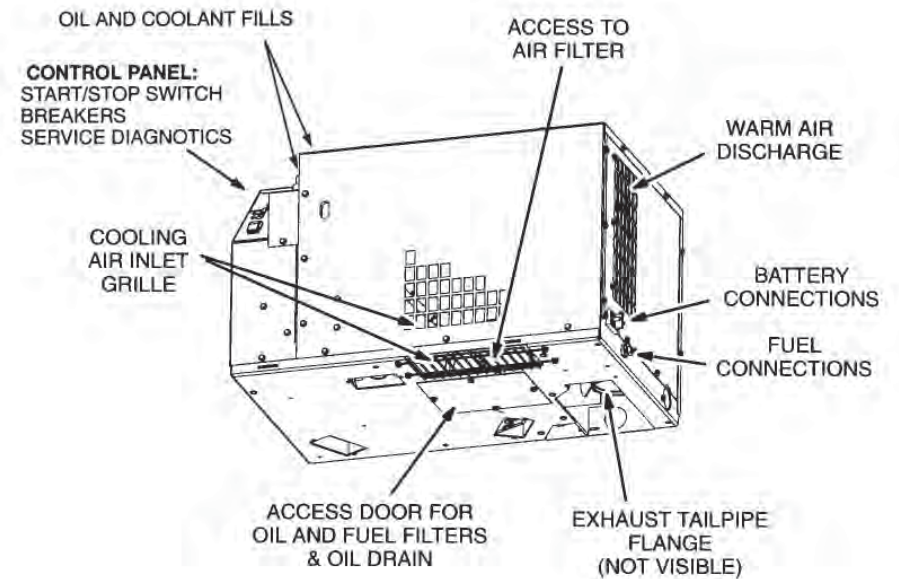

RV QD 6000/8000

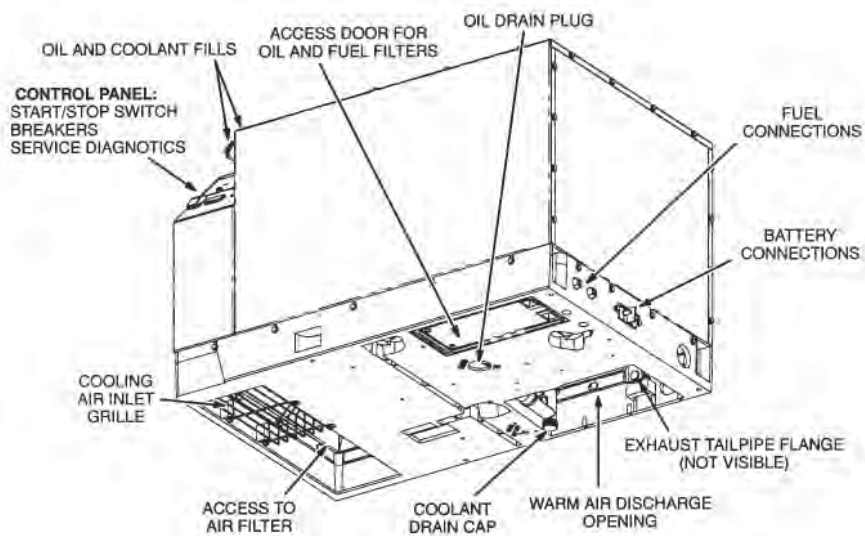

HQD 8/10

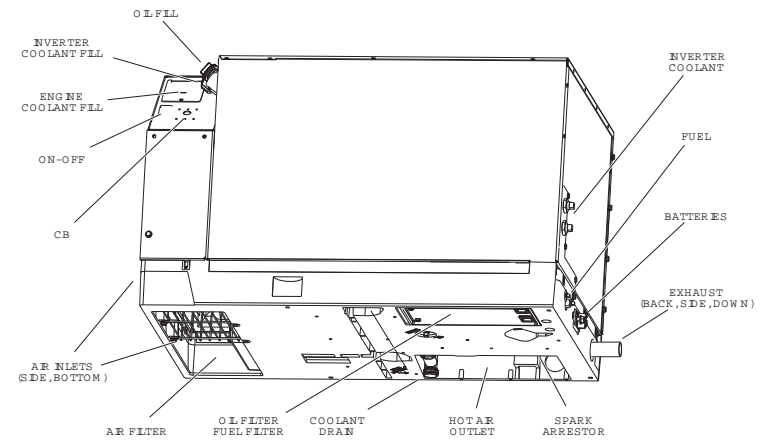

RV QD 10000/12500

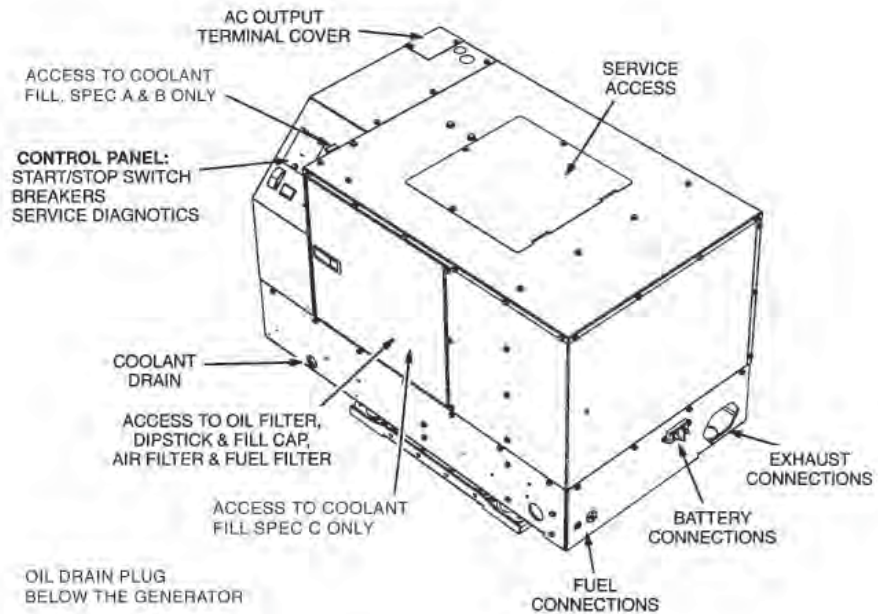

HQD 12/18

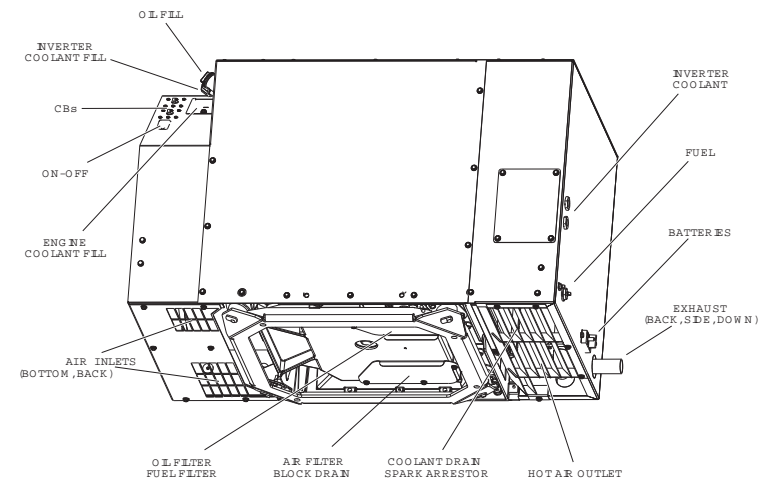



VII: Generator Maintenance: Parts & Chemicals

Insist On The Quality Of Green Label Parts™

Green Label replacement and maintenance products have been specially designed for Cummins Onan RV generator use to provide you with dependable power and performance for the life of your generator. They are available from all Cummins Onan Authorized RV Service and Parts Dealers.

You can also order maintenance parts online at [Funroads™.com](http://Funroads.com). See pages 40-49 for part numbers by set.

Air Filters

Green Label Parts air filters are designed with a special foam pre-cleaner, for use specifically in Cummins Onan RV generators. Other manufacturers' air filters may contain a lighter density filter paper and the sealing surfaces may get brittle and crack over time, allowing dirty air into the engine intake system. Over time, it only

takes about a thimbleful of dirt to wear out piston rings and cylinders. (Replacement filters for some older models may not include the pre-cleaner.)

Spark Plugs

The use of Green Label, resistive, original equipment spark plugs will keep your Cummins Onan genset working properly. Use of other non-resistive plugs can cause generator shut downs without fault codes.

Oil Filters

Green Label Parts oil filters feature valves that allow oil to bypass the oil filter during cold starts, or if the filter becomes plugged. Other manufacturers' oil filters often do not have bypass valves. As these "will-fit" filters trap debris, oil pressure starvation can occur, leading to high oil pressures, failed gaskets and even engine damage. Other "will-fit" oil filters do contain bypass valves but they do not determine at what PSI the valve opens. If the setting is too high, the filter's paper element can be damaged during a cold start rendering it useless, or cause oil starvation to the engine.

Tune-Up Kits

Green Label Parts spark plugs, points and condenser are available for Cummins Onan Quiet Gasoline, Quiet Diesel, Emerald™, MicroLite™ and many older-model Onan RV generators.

Cable Pack Kit

Includes two high-tension plug wire leads and boots for Cummins Onan Quiet Gasoline, Quiet Diesel, Emerald, Marquis™, MicroLite and many older-model Onan RV generators. Designed to keep RFI (Radio & TV Interference) at a minimum for optimum appliance performance.

Fuse Pack Kit

Pack of five fuses for use in most Cummins Onan RV generators.

Oil Filter Wrench

Cup-type for easy removal of Cummins Onan RV generator oil filters. Part #420-0577

Important: Cummins Power Generation warrants only the quality and integrity of Green Label Parts. Any damage caused by the use of non-Green Label Parts filters will not be covered under the Cummins Onan limited warranty.



USE CUMMINS ONAN OIL AND SERVICE/ MAINTENANCE CHEMICALS TO INSURE PERFORMANCE

OnaMax™ 15W-40 Oil And SAE-30

Factory recommended and tested. Maximum protection engine oil formulated to reduce consumption and engine wear due to high temperature oil oxidation and viscosity increase. 32 oz. bottle.

SAE-30 #326-5339

15W-40 #326-5336

OnaFresh™ GXLP Fuel Stabilizer

A premium fuel additive specially formulated for long-lasting prevention of gasoline breakdown during extended RV storage. Protects gasoline against gum, varnish and sludge formation, and fuel system corrosion. 16 oz. bottle treats 40 gallons of gasoline. #326-5365

Onagard™ Storage Fogging Spray

Protects small engines and other mechanical equipment during off-season storage. Provides protection for up to six months. 12-oz. aerosol can. #326-5288

Cummins Onan Premium Fuel System Cleaner

Promotes smoother, more efficient gasoline engine operation. Cleans dirty carburetors and fuel injection systems; removes fuel system gum and varnish; reduces valve and intake deposits. 12-oz. bottle treats up to 24 gallons of gasoline. #326-5342

4C Combustion Chamber And Carburetor Cleaner

Removes power-robbing buildup of carbon, gum and varnish. Regular use can extend intervals between combustion chamber carbon maintenance cleanings. 12-oz. aerosol can provides carbon removal for one generator. #326-5278

When reliability counts, insist on Green Label Parts.™ Genuine Cummins Onan.

Brand Name Model/Series	Spec Letter	Tune-up Kit	Oil Filter	Air Filter	Fuel Filter	Glow Plug or Spark Plug	Plug Wire
OG RM (Camp Power™)							
KVD	A-B	Electronic Ignition	—	140-2105	149-2137	167-0263-02	—
KYD 50 Hz	A-B	Electronic Ignition	—	140-3280	149-2457	167-0305	—
KYD 60 Hz	A-B	Electronic Ignition	—	140-3280	149-2457	167-0275	—
Emerald Advantage™							
Gasoline/HGJAC	A-C	Electronic Ignition	122-0836	140-3116	149-2629	167-1638	—
LP Vapor/HGJAC	A-C	Electronic Ignition	122-0836	140-3116	149-2648	167-1638	—
Emerald™							
BGE	A-E	160-1378	122-0645	140-2379	—	167-0272	9" 167-1615-01 26" 167-1602
Prior to 9/87 NHEL Begin 9/87 NHEL	F	160-1378 160-1349-01	122-0645	140-2379	149-2279	167-0272	9" 167-1615-01 26" 167-1602
BGE	G	Electronic Ignition	122-0645	140-2379	149-2279	167-0272	9" 167-1615-01 26" 167-1602
BGE	H	Electronic Ignition	122-0645	140-2379	149-1353	167-0272	9" 167-1615-01 26" 167-1602
BGE	J-P	Electronic Ignition	122-0645	140-2379	149-2333	167-0272	9" 167-1615-01 26" 167-1602
BGEL	A-E	160-1378	122-0645	140-2379	148-0898	167-0272	9" 167-1615-01 26" 167-1602

Brand Name Model/Series	Spec Letter	Tune-up Kit	Oil Filter	Air Filter	Fuel Filter	Glow Plug or Spark Plug	Plug Wire
NHE	A-E	160-1378	122-0800	140-2379	—	167-0272	9" 167-1615-01
Prior to 9/87 NHE	F	160-1378	122-0800	140-2379	149-2279	167-0272	9" 167-1615-01
Begin 9/87 NHE		160-1349-01					26" 167-1602
NHE	G	Electronic Ignition	122-0800	140-2379	149-2279	167-0272	9" 167-1615-01 26" 167-1602
NHE	H	Electronic Ignition	122-0800	140-2379	149-1353	167-0272	9" 167-1615-01 26" 167-1602
NHE	J-P	Electronic Ignition	122-0800	140-2379	149-2333	167-0272	9" 167-1615-01 26" 167-1602
NHEL	A-E	160-1378	122-0800	140-2379	148-0898	167-0272	9" 167-1615-01 26" 167-1602
RV QG (Marquis™)							
Gasoline/BGM	A-F	Electronic Ignition	122-0645	140-2379	149-2279	167-0272	9" 167-1625-01
Gasoline/BGM	G-H				149-2341		23" 167-1625-02
Gasoline/NHM	A-F	Electronic Ignition	122-0800	140-2379	149-2279	167-0272	167-1602
Gasoline/NHM	G-H				149-2341		
LP/NHM	All	Electronic Ignition	122-0800	140-2379	148-0898	167-0272	167-1602
RV QG (Marquis Gold™)							
Gasoline/HG-JAB	A	Electronic Ignition	122-0836	140-3116	149-2629	167-1638	—
LP/HG-JAB					149-2648		

RV QG (Marquis Platinum™)

EFI/HG-JAA	A	Electronic Ignition	122-0836	140-3116	147-0860	167-1638	—
LP/HG-JAA					149-2648		
RV QG (MicroLite™)							
KV	A-K			140-2105	149-2137	167-0263-02	—
KVC	A-C	Electronic Ignition	—				
KY	A			140-2609	149-2457	167-0305	—
KY 50 Hz	B-L		—	140-3295	149-2457	167-0305	—
KY 60 Hz	A	Electronic Ignition		140-2609	149-2457	167-0275	—
	B-L			140-3295			
RV QG (MicroQuiet™)							
KY 50 Hz	J-L	Electronic Ignition	—	140-3280	149-2457	167-0305	—
KY 60 Hz				140-3295		167-0275	Brand N
RV QG (Quiet Diesel™)							
HDCAA	A-C	—	187-1000	140-3071	149-2513	187-1289	—
HDCAB							
HDKAH							
HDKAJ	A-H	—	122-0833	140-2897	149-2513	185-5421	—
HDKAK							
HDKBA	A	—	185-7444	140-3351	149-2513	185-5421	—
HDKCA	A	—	122-0893	140-3071	149-2513	185-5990	—
HDKCB							

Brand Name Model/Series	Spec Letter	Tune-up Kit	Oil Filter	Air Filter	Fuel Filter	Glow Plug or Spark Plug	Plug Wire
Older Onan® Generators							
BF Power Drawer	A	160-1154, 312-0069	122-0645	140-1220	—	167-0262	167-1616-01
BF RV	A-B	160-1328-01	—	—	—	167-0237	—
BFA RV	A	160-1328-01	122-0645	140-0495	—	167-0237	167-1616-01
BFA RV	B-D	160-1348-01	—	—	—	167-0298	—
BGA RV	A	160-1328-01	122-0645	140-0495	—	167-0237	167-1616-01
BGA RV	B-D	160-1348-01	—	—	—	167-0298	—
BGAL RV	C	160-1348-01	122-0645	140-0495	—	167-0298	167-1616-01
NH Power Drawer	A	160-1154, 312-0069	122-0800	140-1229	—	167-0262	167-1616-01
NH Power Drawer 9000	A-H	160-1154, 312-0069	122-0800	140-1229	—	167-0262	167-1616-01
NH RV	A-H	160-0002, 312-0069	—	—	—	167-0241	167-1616-01
NH RV	J-N	160-1328-01	122-0800	140-0495	—	167-0247	—
NH RV	P-R	160-1378	—	—	—	167-0272	—
NHL	P	160-1328-01	122-0800	140-0495	—	167-0272	9" 167-1615-01 26" 167-1602

Older Onan Diesel Generators							
HDKAG	A-B	—	185-5835	140-2842	149-2106	185-6623 185-5421	—
HDKAG	C	—	—	—	—	185-5421	—
HDKAG	D-E	—	—	—	—	—	—
DKC RV	A	—	122-0827	140-2842	149-1914-05	185-2289	—
DKC RV	B	—	—	—	149-2106	—	—
DKD RV	A-B	—	122-0827	140-2842	149-1914-05	185-2289	—
DKD RV	C-E	—	—	—	149-2106	—	—
DKG	A	—	122-0827	140-2680	149-2106	185-2289	—

*Ask your Onan Authorized RV Service and Parts Dealer to assist you in identifying the correct maintenance parts for these models.



VIII: Warranty & Service

Standard 3-Year Limited Warranty With Available 5-Year Extended Coverage

We're so confident in our RV generators, we back them with a standard 3-year limited warranty — the longest, most comprehensive warranty in the business. And for an additional charge, full coverage can be extended to five years, through the Cummins Onan Care Extended Warranty. Whichever you choose, coverage is transferable from one owner to another if you sell your RV during the generator warranty period. See your Cummins Onan Authorized RV Service and Parts Dealer for details.

Largest Authorized Service And Parts Dealer Network In The Industry

Wherever you travel, Cummins Onan Authorized RV Service and Parts Dealers are never far away. Authorized Dealers trained and tested in all aspects of generator operation and maintenance cover every major market in the United States and Canada. Cummins Onan's extensive training and certification process demonstrates our strong commitment to exceptional product service and support. For a free list of Cummins Onan Authorized RV Service Dealers in the United States and Canada, call 1-800-888-6626 and request publication #F-919 or find your closest dealer on Funroads.com.

COACH CARE SERVICE CENTERS GIVE YOU ONE STOP SERVICE AND REPAIR FOR YOUR RV BUMPER TO BUMPER, COAST TO COAST

Coach Care Service Centers are the only nationwide bumper to bumper service network exclusively for motor homes. For chassis work, maintenance, appliance repairs and everything in between, Coach Care provides professional service in a friendly, no-hassle atmosphere. With more than 30 integrally linked Coach Care locations, our work is guaranteed everywhere you travel.

Benefits of Coach Care

- Conveniently located across the United States
- All Coach Care service centers have a reciprocal warranty
- Expert repair from the chassis, to the main drive engine, to your Cummins Onan generator
- State-of-the-art equipment to aid in quick and thorough service
- 24-hour emergency service, 7 days a week

Amenities to make your visit comfortable and convenient

- Complimentary overnight parking with electrical hook-up
- LP Stations*
- Pets welcome*
- Customer lounge
- Sanitation and sewage disposal*

*Available at most facilities

One stop service

- Coach Care technicians provide authorized service on everything from your engine to your appliances.

Cummins Onan

THETFORD
NORCOLD

COUNTRY COACH

Atwood

WR

WORKHORSE
CUSTOM CHASSIS

SPARTAN

RVP
RV Products
A Division of AIRXCEL, Inc.

Cummins

HWH
CORPORATION

Suburban
Manufacturing Company
A Division of AIRXCEL, Inc.

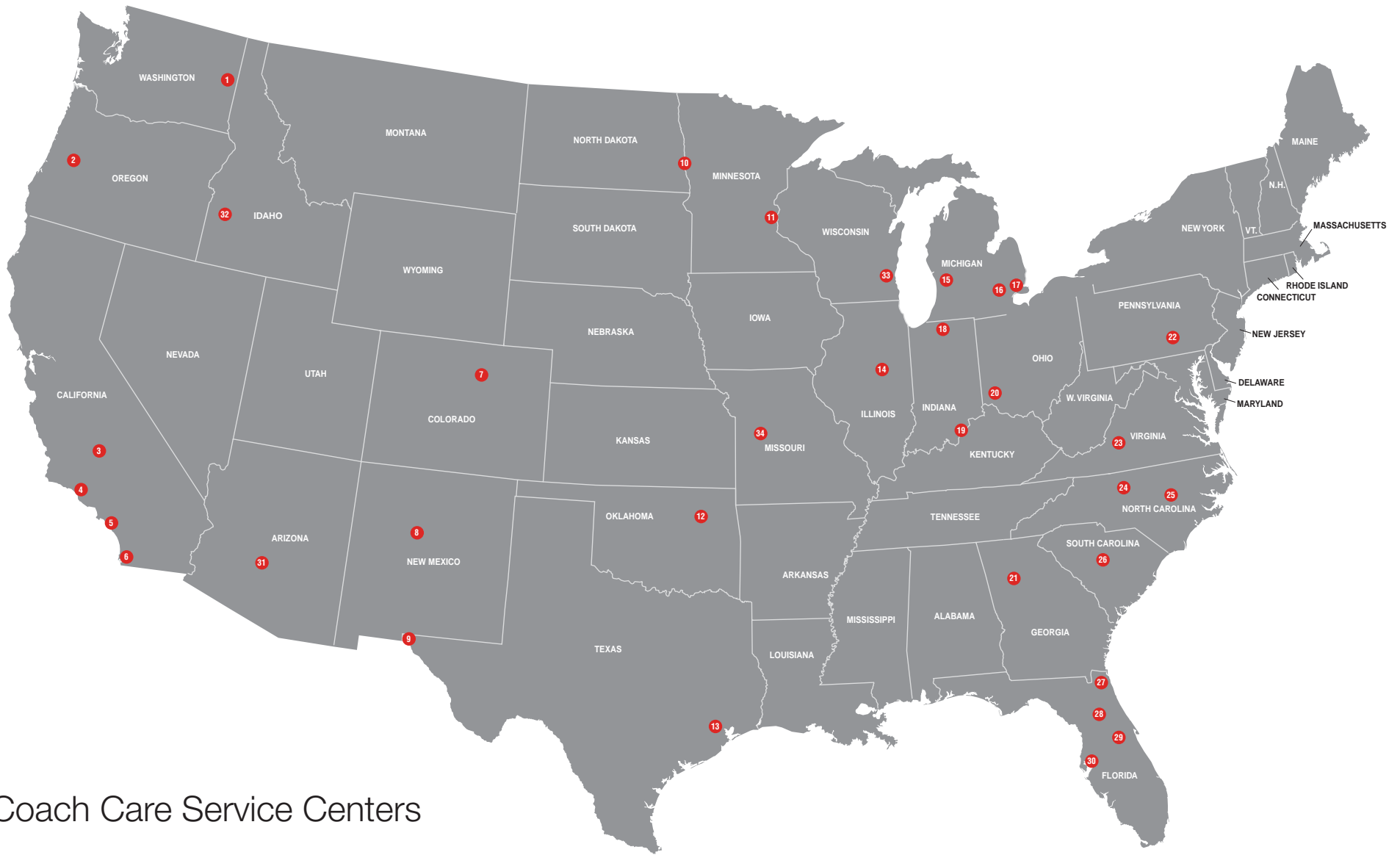

Coach Care Service Centers

Arizona

- 31 Cummins Rocky Mountain**
651 N. 101st Ave.
Phoenix, AZ 85323
Toll free: 800-800-2345

California

- 3 Cummins West**
4601 East Brundage Lane
Bakersfield, CA 93307
Phone: 661-325-9404
- 4 Cummins Cal Pacific**
3958 Transport St.
Ventura, CA 93003
Toll free: 800-881-1159

- 5 Cummins Cal Pacific**
1939 Deere Avenue
Irvine, CA 92606
Toll free: 800-222-4871
- 6 Cummins Cal Pacific**
485 Raleigh Avenue
El Cajon, CA 92020
Toll free: 800-993-4373

Colorado

- 7 Cummins Rocky Mountain**
8211 E 96th Ave.
Henderson, CO 80640
Toll free: 800-927-7201

Florida

- 27 Cummins Power South**
755 Pickettville Road
Jacksonville, FL 32220
Toll free: 800-338-7027
- 28 Cummins Power South**
321 S.W. 52nd Avenue
Ocala, FL 34474
Toll free: 888-699-2774
- 29 Cummins Power South**
4820 N. Orange Blossom Trail
Orlando, FL 32810
Toll free: 800-338-7039
- 30 Cummins Power South**
5910 E. Hillsborough Ave.
Tampa, FL 33610
Toll free: 800-338-2519

Georgia

- 21 Cummins Power South**
5125 Highway 85
Atlanta, GA 30349
Toll free: 800-768-7278

Idaho

- 32 Cummins Rocky Mountain**
8949 South Federal Way
Boise, ID 83716
Toll free: 208-336-5000

Illinois

- 14 Cummins Crosspoint**
450 W. Northtown Rd.
Normal, IL 61761
Toll Free: 800-759-4355

Indiana

- 19 Cummins Crosspoint**
520 Marriott Dr.
Clarksville, IN 47129
Toll free: 800-583-5685

- 18 Onan Indiana**
5125 Beck Drive
Elkhart, IN 46516
Toll free: 800-589-9027

Michigan

- 15 Cummins Bridgeway**
7580 Expressway Drive S.W.
Grand Rapids, MI 49548
Phone: 616-281-2211
- 16 Cummins Bridgeway**
54250 Grand River Ave.
New Hudson, MI 48165
Toll free: 800-486-4308
- 17 Cummins Bridgeway**
43575 North Gratiot Avenue
Clinton Township, MI 48036
Phone: 586-469-2010

Minnesota

- 11 Cummins NPower**
1600 Buerkle Road
White Bear Lake, MN 55110
Toll free: 800-642-0085

Missouri

- 34 Cummins Central Power**
8210 NE Parvin Road
Kansas City, MO 64161
Phone: 861-414-8200

New Mexico

- 8 Cummins Rocky Mountain**
1921 Broadway N.E.
Albuquerque, NM 87102
Toll free: 800-800-3888

North Carolina

- 24 Cummins Atlantic**
513 Preddy Blvd.
Greensboro, NC 27406
Phone: 336-275-4531

- 25 Cummins Atlantic**
350 Cummins Dr.
Kenly, NC 27542
Toll free: 888-288-7181

North Dakota

- 10 Cummins NPower**
3801 34th Avenue S.W.
Fargo, ND 58104
Toll free: 800-373-2466

Ohio

- 20 Cummins Bridgeway**
5400 Rialto Rd.
West Chester, OH 45069
Toll free: 877-678-7744

Oklahoma

- 12 Cummins Southern Plains**
16525 East Skelly Drive
Tulsa, OK 74116
Toll free: 800-722-2743

Oregon

- 2 Cummins Northwest**
91201 Coburg Industrial Parkway
Coburg, OR 97408
Toll free: 866-236-2167

Pennsylvania

- 22 Cummins Power Systems**
4499 Lewis Rd.
Harrisburg, PA 17111
Toll free: 800-841-1344

South Carolina

- 26 Cummins Atlantic**
2791 Shop Road Extension
Columbia, SC 29209
Toll free: 800-695-5383

Texas

- 9 Cummins Rocky Mountain**
14333 Gateway West
El Paso, TX 79928
Toll free: 800-800-4240
- 13 Cummins Southern Plains**
7045 N. Loop East
Houston, TX 77028
Toll free: 800-474-7421

Virginia

- 23 Cummins Atlantic**
263 Simmons Dr.
Cloverdale, VA 24077
Toll free: 800-280-4582

Washington

- 1 Cummins Northwest**
11134 W. Westbow Blvd.
Spokane, WA 99224
Toll free: 800-825-2122

Wisconsin

- 33 Cummins NPower**
800 West Ryan Road
Oak Creek, WI 54476
Phone: 414-768-7400

XI: Current RV Generator Model Information

Introducing Cummins Onan Inverter Portables



P1700 i



P3200 ie



P4300 ie

- Quiet and lightweight, the 43 pound P1700i is an easy to handle power option custom made for life on the road. Its 1400 watts of inverted power make it perfect for most RV microwaves, televisions and other simple luxuries.
- A significant step up, the P3200ie easily handles a 13,500 btu air conditioner. Electric start, 2800 watts continuous and an integrated wheel system make the P3200ie as easy to use as it is powerful.
- The biggest inverter model, the P4300ie, is powerful enough to run one 15,000 btu air conditioner with power to spare. Equipped with electric start and 3800 watts of continuous power, the P4300ie is a serious generator.

	P1700i	P3200ie	P4300ie
Features			
Operating Time(at rated load)	4 Hours	6.5 Hours	5.3 Hours
Operating Noise	59 dB(A)	58 dB(A)	62 dB(A)
Start System	Manual	Electric	Electric
Fuel Capacity	1.1 Gal.	2.9 Gal.	3.4 Gal.
Outlet	120V GFCI Protected Duplex		
Std. Wheels	NA	4	4
Warranty	2-Year Limited		

RV QD 3200



RV QD 3200

- Computer-controlled constant speed operation - Quiet Diesel performance for small RVs.
- Special sound-controlling housing encloses cooling system and muffler
- Double isolation mounting system reduces vibration
- Easily accesible maintenance points
- Runs one rooftop air conditioner with power to spare
- Intergrated start/stop control with hour meter

RV QD 3200 Specifications

Model	3200
Watts	3200
Volts	120
Hertz	60
Amps	26.7
Weight (lb)	205 lbs.
Avg. Fuel Consumption	(gal/hr)
No Load	0.2
Half Load	0.3
Full Load	0.4
Sound Level	dB(A)
Full Load	68 dB(A)

*Typical RV installation. All readings at 10 ft. (3m).

Dimensions: (L x W x H in inches)

3200 QD: 30.2 x 17.3 x 18.0

Engine Detail:

4-cycle, air-cooled, single-cylinder diesel

Power Capability: (at 100°F and 500' altitude)

- Starts one 13500 BTU air conditioner with up to a 1000-watt baseload.

RV QG 2800/2500 RM, 4000/3600 RM Remote Muffler Generator Models

The First Installed Generators for Travel Trailers, Truck Campers and Folding Camping Trailers.



RV QG 2800 RM



RV QG 4000 RM

RV QG 2800 and 2500 LP RM

- Runs one 13500 BTU air conditioner with power to spare.
- Lightweight, compact design that's easy to install.
- Fully-enclosed design for reduced noise.
- Front access panel for easy service and maintenance.
- Gasoline or LP-fueled.

RV QG 4000 and 3600 LP RM

Includes all the features and benefits above, PLUS...

- Microprocessor control with diagnostics for easy troubleshooting.

RV QG RM Specifications

Model	2800	2500 LP	4000	3600 LP
Watts	2800	2500	4000	3600
RPM	3600	3600	3600	3600
Volts	120	120	120	120
Hertz	60	60	60	60
Amps	23.3	20.8	33.3	30.0
Weight (lb)	107	107	167	167
Avg. Fuel Consumption	(gal/hr)	(gal/hr) (lb/hr)	(gal/hr)	(gal/hr) (lb/hr)
No Load	0.2	0.2 0.9	0.3	0.4 1.7
Half Load	0.3	0.3 1.3	0.5	0.6 2.6
Full Load	0.4	0.5 2.1	0.7	0.7 3.0
Sound Level dB(A)				
Half Load*	71	71	70	70
Engine Horsepower	7	7	9.5	8.6

*Typical RV installation. All readings at 10 ft. (3m).

Dimensions: (L x W x H in inches)

2800 & 2500 LP: 19.6 x 16.7 x 12.3

4000 & 3600 LP: 25.7 x 19.7 x 14.4

Engine Detail:

4-cycle, single cylinder, overhead valve.

Power Capabilities: (at 100°F and 500' feet altitude)

- **RV QG 2800 RM:** Starts one 13500 BTU air conditioner with approved start circuit, plus 600-watt baseload. Or, one 11000 BTU air conditioner with approved start circuit, plus 1000-watt baseload.
- **RV QG 2500 RM LP:** Starts one 13500 BTU air conditioner with approved start circuit, plus 300-watt baseload. Or, one 11000 BTU air conditioner with approved start circuit, plus 600-watt baseload.
- **RV QG 4000 RM:** Starts one 13500 BTU air conditioner, plus 2000-watt baseload.
- **RV QG 3600 RM LP:** Starts one 13500 BTU air conditioner, plus 1600-watt baseload.

RV QG 2800/2500, 4000/3600 Lightweight, Compact and Quiet Gasoline/LP RV Generators



RV QG 2800



RV QG 4000

RV QG 2800

- Runs one 13500 BTU air conditioner with power to spare and easy-start motor circuit.
- Lightweight and compact.
- Single-side service for easy maintenance.
- Fully-enclosed muffler.
- Gasoline or LP-fueled.

RV QG 4000

Includes all the features and benefits above, PLUS...

- Microprocessor control with diagnostics for easy troubleshooting.

RV QG Specifications

Model	2800	2500 LP	4000	3600 LP		
Watts	2800	2500	4000	3600		
RPM	3600	3600	3600	3600		
Volts	120	120	120	120		
Hertz	60	60	60	60		
Amps	23.0	20.8	33.3	30.0		
Weight (lb)	113	113	172	172		
Avg. Fuel Consumption	(gal/hr)	(gal/hr)	(lb/hr)	(gal/hr)	(gal/hr)	(lb/hr)
No Load	0.2	0.2	0.9	0.3	0.4	1.7
Half Load	0.3	0.3	1.3	0.5	0.6	2.6
Full Load	0.4	0.5	2.1	0.7	0.7	3.0
Sound Level dB(A)						
Half Load*	70	70	66	66		
Engine Horsepower	7	7	9.5	8.6		

*Typical RV installation. All readings at 10 ft. (3m).

Dimensions: (L x W x H in inches)

2800 & 2500 LP: 24.0 x 16.4 x 12.3

4000 & 3600 LP: 30.0 x 19.7 x 14.4

Engine Detail:

4-cycle, single cylinder, overhead valve.

Power Capabilities: (at 100°F and 500' altitude)

- **RV QG 2800:** Starts one 13500 BTU air conditioner with approved start circuit, plus 600-watt baseload. Or, one 11000 BTU air conditioner with approved start circuit, plus 1000-watt baseload.
- **RV QG 2500 LP:** Starts one 13500 BTU air conditioner with approved start circuit, plus 300-watt baseload. Or, one 11000 BTU air conditioner with approved start circuit, plus 600-watt baseload.
- **RV QG 4000:** Starts one 13500 BTU air conditioner, plus 2000-watt baseload.
- **RV QG 3600 LP:** Starts one 13500 BTU air conditioner, plus 1600-watt baseload.

RV QG 5500, 7000 / 6500



RV QG 5500



RV QG 7000

- Runs one or two 13500 BTU air conditioners with power to spare.
- Fully integrated design makes it the quietest in its class.
 - Enclosed muffler
 - Low vibration levels
 - Self-diagnostic capability to simplify troubleshooting
 - Digital voltage regulation for stability as appliance loads change
- Gasoline or LP-fueled.

RV QG 5500/7000/6500 Specifications

Model	5500	5500 LP	7000	6500 LP		
Watts	5500	5500	7000	6500		
RPM	2400	2400	2880	2880		
Volts	120	120	120	120		
Hertz	60	60	60	60		
Amps	45.8	45.8	58.3	54.2		
Weight (lb)	279	279	290	290		
Avg. Fuel Consumption	(gal/hr)	(gal/hr)	(lb/hr)	(gal/hr)	(gal/hr)	(lb/hr)
No Load	0.3	0.4	1.7	0.4	0.4	1.7
Half Load	0.6	0.8	3.4	0.7	0.8	3.4
Full Load	0.9	1.1	4.7	1.2	1.2	5.1
Sound Level dB(A)						
Half Load*	67	67	67	67	67	67
Engine Horsepower	12.9	10.7	14.0	11.6		

*Typical RV installation. All readings at 10 ft. (3m).

Dimensions: (L x W x H in inches)

All Models: 33.6 x 22.2 x 16.7

Engine Detail:

4-cycle, OHV, 90-degrees V-Twin.

Power Capabilities: (at 100°F and 500' altitude)

- **RV QG 5500/5500 LP:** Starts one 13500 BTU air conditioner with 3000-watt baseload. Or, two 13500 BTU air conditioners with 1300-watt baseload.
- **RV QG 7000/6500 LP:** Starts two 13500 BTU air conditioners with 3000-watt baseload.

RV QG 5500, 7000/6500 EFI



RV QG 5500 EFI



RV QG 7000 EFI

RV QG 5500/7000 EFI

- Electronic fuel injection.
 - Improved hot and cold starts
 - Automatic altitude compensation
 - No carburetor gumming after storage
- Runs one or two 13500 BTU air conditioners with power to spare.
- Electronic governor.
- Fully integrated design makes it the quietest in its class.
 - Enclosed muffler
 - Low vibration levels
 - Self diagnostic capability to simplify troubleshooting
 - Digital voltage regulation for stability as appliance loads change
- Gasoline or LP-fueled.

RV QG 5500/7000/6500 EFI Specifications

Model	5500 EFI	5500 LP	7000 EFI	6500 LP		
Watts	5500	5500	7000	6500		
RPM	2400	2400	2880	2880		
Volts	120	120	120	120		
Hertz	60	60	60	60		
Amps	45.8	45.8	58.3	54.2		
Weight (lb)	279	279	290	294		
Avg. Fuel Consumption	(gal/hr)	(gal/hr)	(lb/hr)	(gal/hr)	(gal/hr)	(lb/hr)
No Load	0.3	0.4	1.7	0.4	0.5	2.1
Half Load	0.6	0.8	3.4	0.7	0.8	3.4
Full Load	0.9	1.1	4.7	1.1	1.2	5.1
Sound Level dB(A)						
Half Load*	64	64	64	64	64	64
Engine Horsepower	12.9	10.7	12.3	11.6		

*Typical RV installation. All readings at 10 ft. (3m).

Dimensions: (L x W x H in inches)

All models 33.6 x 22.2 x 16.7

Engine Detail:

4-cycle, OHV, 90-degree V-Twin.

Power Capabilities: (at 100°F and 500' altitude)

- **RV QG 5500/5500 EFI LP:** Starts one 13500 BTU air conditioner with 3000-watt baseload. Or, two 13500 BTU air conditioners with 1300-watt baseload.
- **RV QG 7000/6500 EFI LP:** Starts two 13500 BTU air conditioners with 3000-watt baseload.

RV QD 5000, 6000, 8000, 10000, 12500

So Quiet And Smooth Running, You Won't Believe They're Diesels!



RV QD 5000



RV QD 8000



RV QD 12500

RV QD 5000

- Runs one or two 13500 BTU air conditioners with power to spare.
- Compact design perfect for small diesel coaches.
- High-quality sine wave electrical output maximizes appliance efficiency.
- Self-diagnostic capabilities simplify troubleshooting.
- Enclosed muffler for easy installation and quiet operation.

RV QD 6000/8000

- Runs two 13500 BTU air conditioners with power to spare.
- Computer-controlled variable speed operation — matches engine speed to load demand, minimizing noise level.
- High-quality pure sine wave electrical maximizes appliance efficiency.
- Self diagnostic capabilities simplify troubleshooting.
- Special sound-controlling housing encloses cooling system and muffler.
- Three-point, fully focalized mounting system reduces vibration.

RV QD Specifications

Model	5000	6000	8000	10000	12500
Watts	5000	6000	8000	10000	12500
Volts	120	120	120	120/240	120/240
Hertz	60	60	60	60	60
Amps	45.8	62.5	66.6	83.3/41.7	104.0/52.0
Weight (lb)	400	420	420	690	715
Avg. Fuel Consumption	(gal/hr)	(gal/hr)	(gal/hr)	(gal/hr)	(gal/hr)
No Load	.25	0.13	0.13	0.11	0.11
Half Load	.41	0.49	0.49	0.43	0.48
Full Load	.66	0.96	1.02	1.0	1.2
Sound Level dB(A)	0.3	0.3	1.3	0.5	0.6
Half Load*	68	68	68	68	68
Engine Horsepower	10.7	16.6	16.6	27	27

*Typical RV installation. All readings at 10 ft. (3m).

RV QD 10000/12500

- Runs two or three 13500 BTU air conditioners with power to spare.
- High-quality sine wave electrical output maximizes appliance efficiency.
- Self-diagnostic capabilities simplify troubleshooting.
- Special sound-controlling housing encloses cooling system and muffler.
- Three-point, fully focalized mounting system reduces vibration.

Dimensions: (L x W x H in inches)

RV QD 5000: 34.5 x 22.4 x 20.3

RV QD 6000/8000: 36.3 x 23.6 x 22.3

RV QD 10000/12500: 41.4 x 24.5 x 27

Engine Detail:

4-cycle, 3-cylinder inline vertical, liquid-cooled diesel engine.

Power Capabilities:

- **RV QD 5000:** Runs two 13500 BTU air conditioners with 1500-watt baseload.
- **RV QD 6000/8000:** Runs two 15000 BTU air conditioners with 3100-watt baseload.
- **RV QD 10000/12500:** Runs three 15000 BTU air conditioners with a 4000-watt baseload.

Hybrid Quiet Diesel - Introducing A Revolutionary New RV Power System



Auto. OK. Done.



- Integrated power system manages battery, generator and shore power together
- Single control provides simple automatic mode
- Up to 20% fuel savings
- Boost mode provides additional motor starting power
- Significantly lower noise & vibration
- High-quality pure sine wave electrical output helps prevent damage to appliances
- Intelligent transfer switch monitors power quality
- For more info, www.cumminsonan.com

Models and ratings

Model	Hz	Generator mode watts*	Voltage	Phase	Inverter/boost watts
810HQDSA-6028A	60	7500/10000	120	1	3000/2500
1215HQDSB-6042A	60	12000/15000	120/240	1	3000/3000
1218HQDSB-6037A	60	12000/18000	120/240	1	6000/6000

* Boost watts added to generator set watts for peak performance. Duration depends on size/status of batteries.

Ambient conditions for rated power output with muffler and RV enclosure, per ISO 8528-1:

- Temperature: 77° F (25° C)
- Altitude: 500 ft (152.4 m), (99 kPa dry)

Typical power output change based on ambient conditions:

- Temperature: Power output decreases 1% for every 10° F (5.5° C) increase
- Altitude: Power output decreases 3.5% for every 1000 ft (305 m) increase

Ratings represent minimums. Actual performance may be significantly higher based on installation and operating conditions.

Weight, size and sound level

	8 Power Unit	12 Power Unit	
Weight:	391 lb (177 kg)	485 lb (220 kg)	
Size:	36.6 in x 23.6 in x 22 in (929.6 mm x 599.4 mm x 558.8 mm)	41.1 in x 24.1 in x 27 in (1043.9 mm x 612.1 mm x 685.8 mm)	
	Transfer switch	Inverter	
Weight:	17 lb (8 kg)	55 lb (25 kg)	
Size:	12.6 in x 12 in x 4.4 in (320 mm x 304.8 mm x 111.76 mm)	21.1 in x 13.4 in x 6.4 in (535.9 mm x 340.4 mm x 162.6 mm)	
Sound:	Readings at 10 ft (3 m)		
	No load	Half load	Full load
810HQD	56 dB(A)	63 dB(A)	66 dB(A)
1215HQD	59 dB(A)	63 dB(A)	69 dB(A)
1218HQD	59 dB(A)	63 dB(A)	69 dB(A)
	- Meets National Park Service sound level requirements (60 dB(A) @ 50 ft) for use in national parks.		
	- Typical installation will further reduce sound level.		

Energy Command 15, 20 and 30



A new line of remote power management panels that provides worry-free control for Cummins Onan diesel, gas, or LP generators.

Installation Features:

- Compatible with Cummins Onan generators
- Easy to install in production
- Works with any type of battery
- Up to three individual start request inputs (for three air-conditioners, etc.)
- Menu allows customization and access to system data
- Magnetic overlay covers mounting screws for clean appearance
- Installation mounting hole location same as standard Cummins Onan remote
- Inputs for house and engine battery voltage
- Amp/Tyco connector

Energy Command	
Model	20 30
Battery Monitoring	
House battery bank state of charge gauge	• •
House battery bank voltage	• •
Engine battery bank voltage	• •
Generator Monitoring	
Digital generator hour meter	• •
Manual start/stop switch with digital readout	• •
Service reminders	• •
Diagnostic text messages	• •
Automatic Generator Starting Functions	
Programmable "quiet time"	•
Look-ahead battery top-off feature prior to "quiet time"	•
Auto start/stop on low/full battery	•
Auto start/stop for up to three air conditioning systems	•
Built-in memory for all programmable settings	•
Safety Feature	
Safety start inhibit feature	•
Compatibility With Cummins Onan	
Camp Power™	• •
MicroLite™	• •
MicroQuiet™	• •
Marquis Platinum™	• •
Marquis Gold™	• •
Quiet Diesel™	• •

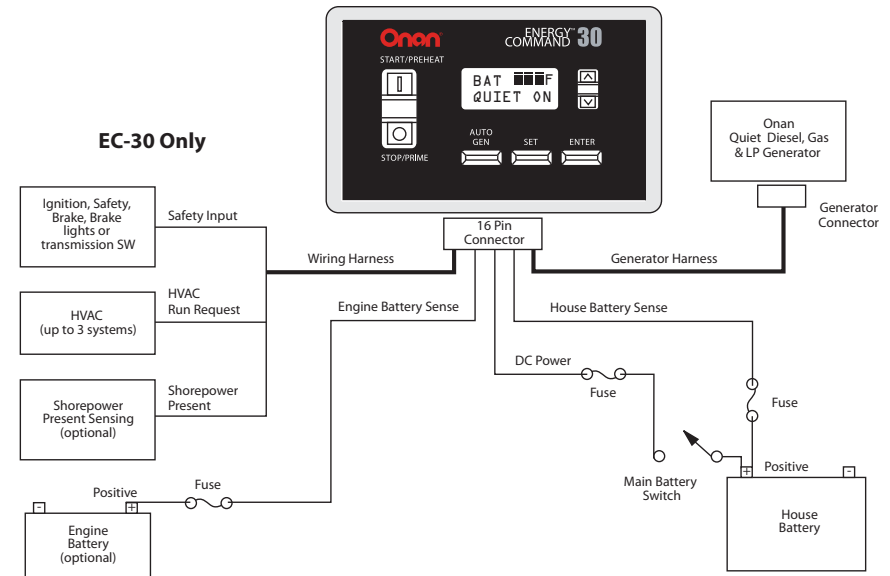

Specifications:

- Voltage:** 8-35VDC (Suitable for 12V or 24V systems)
- Current:** 0.05A @ 12V (With backlight on)
- Dimensions:** (Outside) 5.125" X 3.125" X 1.0"
- Opening:** 3.875" X 2.5"
- Start/stop:** Switch rated at 1.0 amp
- Control outputs:** Rated at 1.0 amp
- Models:** Energy Command 20 (#018-02020)
Energy Command 30 (#018-02030)

RV Power In The Palm Of Your Hand

With the Cummins Onan Energy Command™ 15W (EC-15W)

- Remotely starts and stops your generator from up to 100' away.
- Compatible with all current model Cummins Onan RV generators
- Can be easily installed by the RV owner; instructions included
- Includes key fob remote and receiver that's wired to the generator
- Digitally encrypted code ensures the remote starts only your generator
- LED indicator confirms remote transmission



For more information see www.cumminsonan.com

Inverter/Charger



RV Inverter:

- Maintains full load output at high ambient temperatures
- 3-stage, temperature compensated battery charging and equalization for all battery types
- Low battery shut-off provides longer battery life
- Automatic generator start with programmable 'quiet time' helps maintain optimum battery levels and can start the generator on thermostat request for AC; included at no extra cost
- Battery charge rate 'power share adjust' gives appliances priority to reduce AC breaker trips
- AC and battery terminal blocks for easy installation and secure connections
- FCC Class B radiated EMI performance
- Automatically assumes load when AC power from generator or shore is not available
- Shunt option calculates battery state of charge and usage time remaining
- UL Listed to U.S. and Canadian Safety Standards

Remote Panel:

- Easy-to-use, full text, customer-friendly readout
- Easy-to-interpret diagnostics and fault history on remote panel
- LED lights provide inverter status at a glance
- "Quick-key" for easy charge rate adjustments
- Full AC and DC metering

Inverter/Charger - Size Comparison Chart

Model	2000 kW	3000 kW
Inverter Function		
Max Continuous Output Power AC	2000	3000
Peak Current (Surge rated peak 300%)	50	75
Charger Function		
Max Charge Output DC Amps	100 A dc	140 A dc
Charge Control	3-Stage	3-Stage
Equalization	S	S
Battery Type Settings	wet/gel/agm	wet/gel/agm
Temperature Compensated Charging	S	SS
Transfer Switch		
AC Transfer Switch Amps	30	30
Specifications		
Two Speed Forced Air Cooling	S	S
Specified Temperature Range	-20° C to +40° C	
Enclosure Type	Metal	
Dimensions (L x W x H)	12.2" x 12.8" x 7.3"	
Weight (lbs)	47	51
Recommended Class T DC Fuse	300 A	400 A
Remote Control Panel	O	O
30A Pass Thru	S	S
20/20 Breakers	O	O
15/15 Breakers	O	O
Internal Shunt (for battery level monitoring)	O	S
Auto Generator Start/Stop	S	S
Auto LowBatt Cutout	S	S
Power Sharing	S	S
Fault Diagnosis	S	S
Battery Voltage	12 V DC	12 V DC
AC Input Voltage	120 V AC	120 V AC
AC Output Connections	Terminal Block	
AC Input Connections	Terminal Block	

S=Standard, O=Optional

Introducing JuiceBox Full Generator Power Installed By Your Dealer In Minutes

- Self-contained, hitch-mount generator system for large* trailer and fifth-wheel RVs.
- No wiring or compartment fabrication required
- Saves valuable RV storage space
- Includes wireless key-fob remote start/stop
- Detachable if not needed; reduces RV travel weight
- Can be transferred to your next RV
- Discreet cover provides noise reduction, weather and theft protection
- Easy access to generator simplifies regular maintenance
- Exceptionally quiet
- Available in 4000 watt gasoline and 3600 watt LP models
- For more information see www.cumminsonan.com/juicebox



Record When Scheduled Maintenance Is Performed

Service Item	Service Intervals - Repeat Every										
	Mthly	50 Hrs	100 Hrs	150 Hrs	200 Hrs	250 Hrs	450 Hrs	500 Hrs			
Clean & Check Battery & Connections											
Clean Spark Arrester											
Change Oil/Oil Filter											
Change Air Filter											
Replace Spark Plugs											
Change Fuel Filter											
Schedule Onan Service Center Tune-Up											

Note: See page 23 for General Generator Maintenance Intervals Chart