



DANGER

Danger of electrical shock, burns or death. Always remove all power sources before attempting any repair, service or diagnostic work. Power can be present from shore power, generator, inverter or battery. All power sources must be disabled and secured before performing any service.



CAUTION

If you lack the skills, tools or equipment to perform diagnostic or repair work leave such work to an authorized Winnebago Industries dealer or other qualified shop.

DWG NO.	FEATURE
141390-01	-----
141390-11	(1B1)(12D)
141390-15	(265)(12D)

RELEASE	DATE	BY	TR	ADM	DWG NO	141390
REV	ZONE	REVISION RECORD	DATE	TR	ORIG	

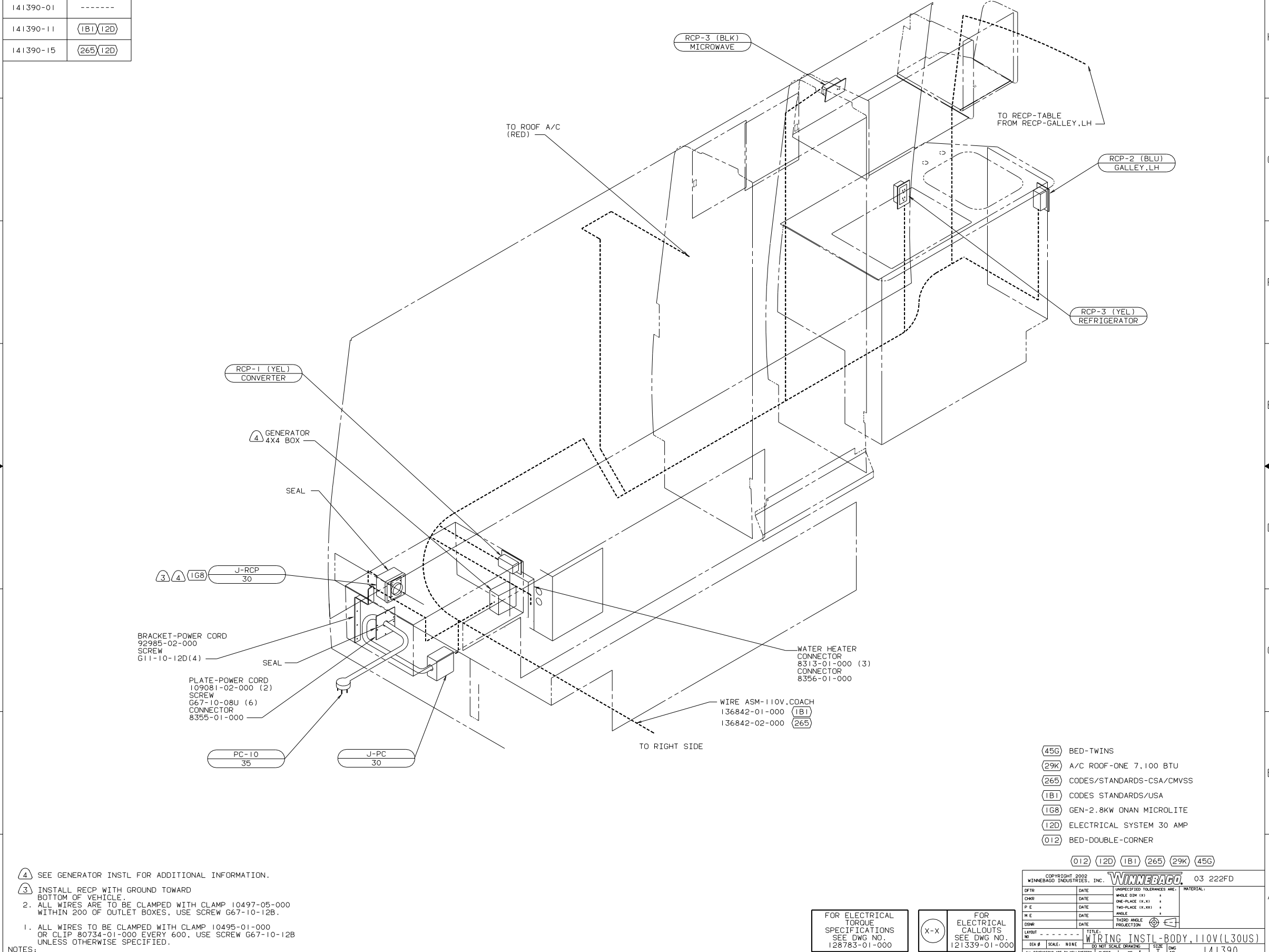

- 4 SEE GENERATOR INSTL FOR ADDITIONAL INFORMATION.
- 3 INSTALL RCP WITH GROUND TOWARD BOTTOM OF VEHICLE.
- 2 ALL WIRES ARE TO BE CLAMPED WITH CLAMP 10497-05-000 WITHIN 200 OF OUTLET BOXES. USE SCREW G67-10-12B.
1. ALL WIRES TO BE CLAMPED WITH CLAMP 10495-01-000 OR CLIP 80734-01-000 EVERY 600. USE SCREW G67-10-12B UNLESS OTHERWISE SPECIFIED.

- (45G) BED-TWINS
- (29K) A/C ROOF-ONE 7,100 BTU
- (265) CODES/STANDARDS-CSA/CMVSS
- (1B1) CODES STANDARDS/USA
- (1G8) GEN-2.8KW ONAN MICROLITE
- (12D) ELECTRICAL SYSTEM 30 AMP
- (012) BED-DOUBLE-CORNER

(012) (12D) (1B1) (265) (29K) (45G)

COPYRIGHT 2002 WINNEBAGO INDUSTRIES, INC.		WINNEBAGO		03 222FD
DATE	UNSPECIFIED TOLERANCES ARE:	MATERIAL:		
DATE	ANGLE	ONE-PLACE (X.X)	+	
DATE	ANGLE	TWO-PLACE (X.XX)	+	
DATE	ANGLE	THIRD ANGLE PROJECTION	+	
DATE	ANGLE	THIRD ANGLE PROJECTION	+	
LAYOUT NO		TITLE: WIRING INSTL-BODY, 110V(L30US)		
DIA #	SCALE: NONE	DO NOT SCALE DRAWING	SHEET	NO
ALL DIMENSIONS ARE IN MILLIMETERS		141390		

FOR ELECTRICAL TORQUE SPECIFICATIONS SEE DWG NO. 128783-01-000



FOR ELECTRICAL CALLOUTS SEE DWG NO. 121339-01-000

FROM RECP-GALLEY, LH
TO RECP-TABLE

3

RCP-2 (BLU)
TABLE

GFI-US (BLU)
NIGHTSTAND
GFI-CA (BLU)
NIGHTSTAND

SWITCH-WATER HEATER
84420-01-000
LABEL
83588-01-000
(WHT)

RCP-E (BLU)
EXTERIOR (39A)

LOAD CENTER
(SEE SHT 4)

TO LEFT SIDE

- 3 WIRE ROUTED BEHIND TRANSITION PANEL.
2. ALL WIRES ARE TO BE CLAMPED WITH CLAMP 10497-05-000 WITHIN 200 OF OUTLET BOXES. USE SCREW G67-10-12B.
1. ALL WIRES TO BE CLAMPED WITH CLAMP 10495-01-000 OR CLIP 80734-01-000 EVERY 600. USE SCREW G67-10-12B UNLESS OTHERWISE SPECIFIED.

NOTES:

- (39A) EXT RECEPTACLE DPLX 120VAC
- (012) BED-DOUBLE-CORNER
- (12D) ELECTRICAL SYSTEM 30 AMP
- (265) CODES/STANDARDS-CSA/CMVSS
- (1B1) CODES STANDARDS/USA

FOR ELECTRICAL
TORQUE
SPECIFICATIONS
SEE DWG NO.
128783-01-000

X-X

FOR
ELECTRICAL
CALLOUTS
SEE DWG NO.
121339-01-000

(1B1) (265) (12D) (012) 03 222FD
TITLE: WIRING INSTL-BODY, 110V(R30)
DO NOT SCALE DRAWING SIZE DWG NO 141390
SHEET 2 OF 4 I.e

FROM RECP-GALLEY
TO RECP-TABLE

RCP-2 (BLU)
TABLE

3

SWITCH-WATER HEATER
84420-01-000
LABEL
83588-01-000
(WHT)

LOAD CENTER
(SEE SHT 4)

RCP-E (BLU)
EXTERIOR 39A

GFI-US (BLU)
NIGHTSTAND
GFI-CA (BLU)
NIGHTSTAND

TO LEFT SIDE

15G

- 3 WIRE ROUTED BEHIND TRANSITION PANEL.
2. ALL WIRES ARE TO BE CLAMPED WITH CLAMP 10497-05-000 WITHIN 200 OF OUTLET BOXES. USE SCREW G67-10-12B.
1. ALL WIRES TO BE CLAMPED WITH CLAMP 10495-01-000 OR CLIP 80734-01-000 EVERY 600. USE SCREW G67-10-12B UNLESS OTHERWISE SPECIFIED.

- 45G BED-TWINS
- 39A EXT RECEPTACLE DPLX 120VAC
- 12D ELECTRICAL SYSTEM 30 AMP
- 265 CODES/STANDARDS-CSA/CMVSS
- 1B1 CODES STANDARDS/USA

FOR ELECTRICAL
TORQUE
SPECIFICATIONS
SEE DWG NO.
128783-01-000

FOR
ELECTRICAL
CALLOUTS
SEE DWG NO.
121339-01-000

1B1 265 12D 45G 03 222FD

TITLE: WIRING INSTL-BODY, 110V(R30)

DO NOT SCALE DRAWING SIZE DWG NO 141390

SHEET 3 OF 4 I.e. No 141390

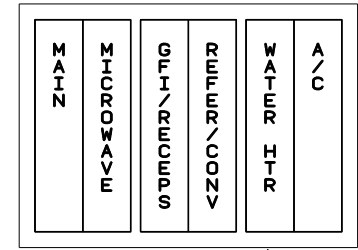
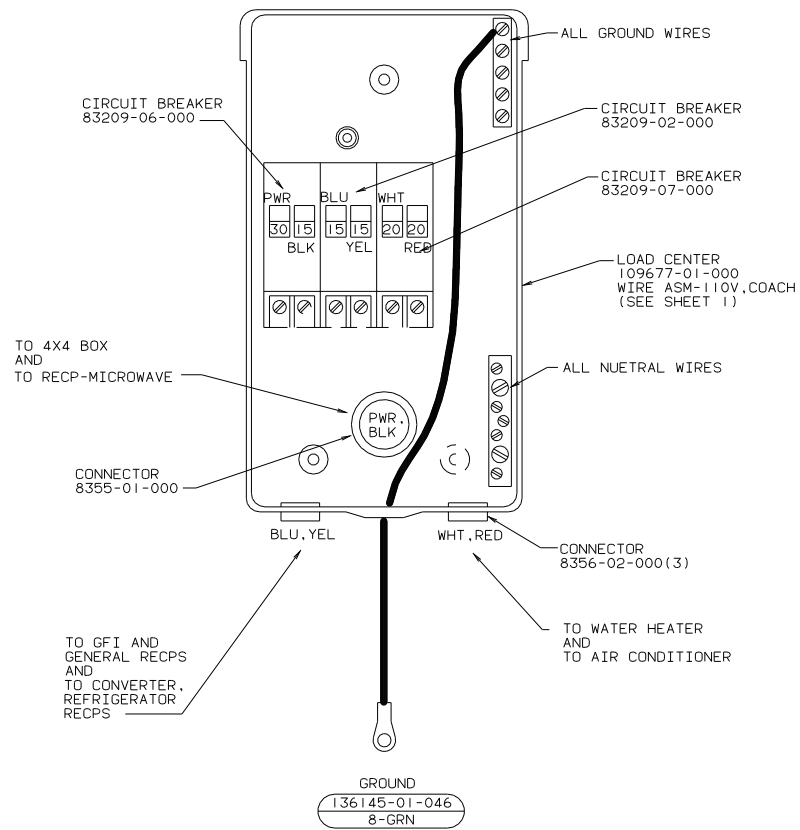

LABEL 95721-38-000

INSTALL LABEL ON BACK SIDE OF CABINET ACCESS DOOR.

NOTES:
1. ALL CABLES SHALL BE COVERED WITH CONDUIT-CONVOLUTE, SLIT 41953-01-000, UNLESS OTHERWISE SPECIFIED, 600 LESS THAN CABLE LENGTH.

FOR ELECTRICAL TORQUE SPECIFICATIONS SEE DWG NO. 128783-01-000

FOR ELECTRICAL CALLOUTS SEE DWG NO. 121339-01-000

- (45G) BED-TWINS
- (265) CODES/STANDARDS-CSA/CMVSS
- (1B1) CODES STANDARDS/USA
- (12D) ELECTRICAL SYSTEM 30 AMP
- (012) BED-DOUBLE-CORNER

(012)	(12D)	(1B1)	(265)	(45G)	03	222FD
TITLE: WIRING INSTL-BODY(LC30)						
DO NOT SCALE DRAWING						
SHEET 4 OF 4				DWG NO		141390