

NOTES: SEE SHT 1 FOR ADDITIONAL INFORMATION.

WIRING DIAGRAM-COACH (ALL BUT TWIN BED OPTION UNITS) (WIRE ASM 119012)

TITLE:		WIRING DIAGRAM-BODY	
30 NET SCALE DRAWING	SHEET	2	OF 5
DATE	DESIGNED BY	11/11	119904

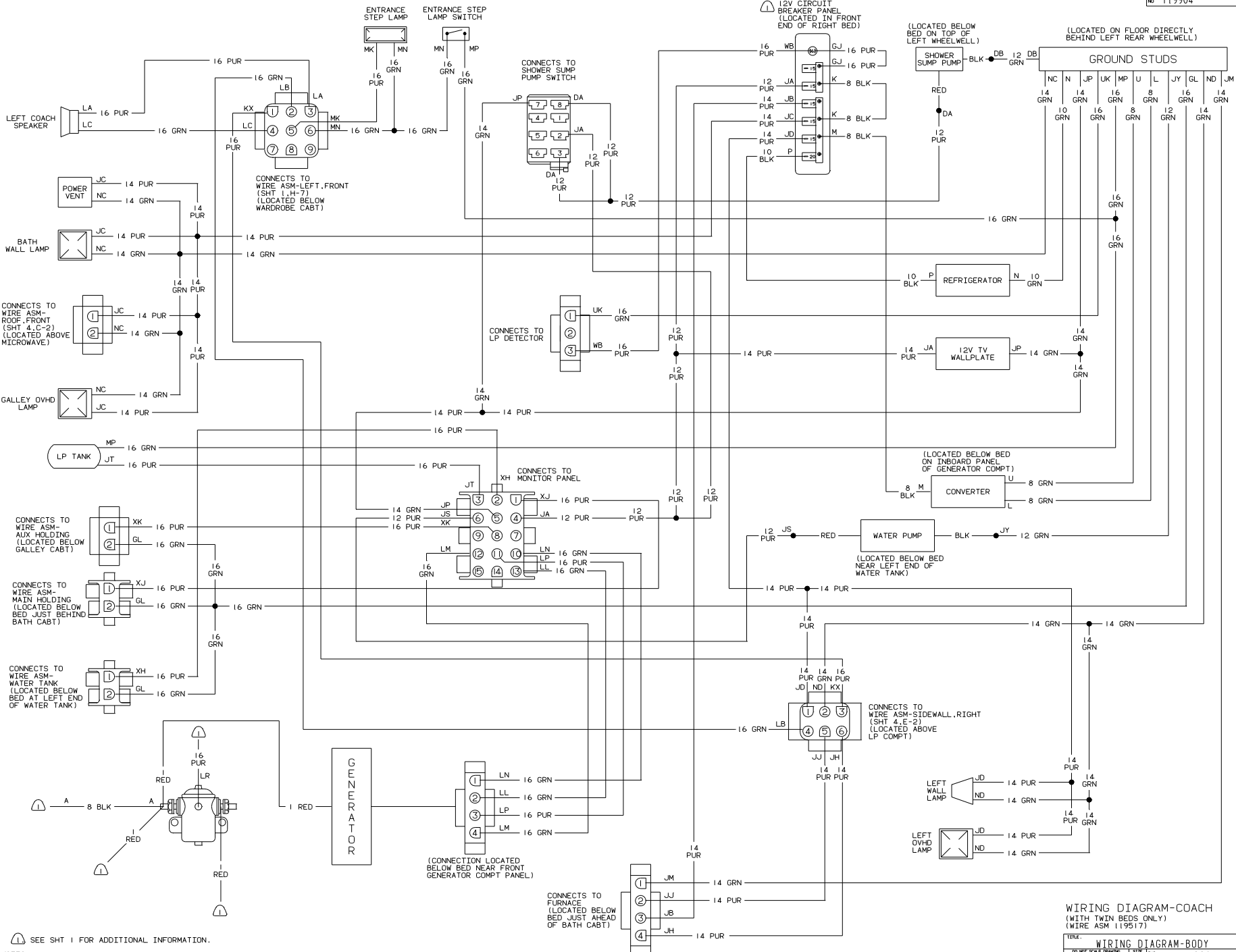

SEE SHIT 1 FOR ADDITIONAL INFORMATION.

NOTES:

WIRING DIAGRAM-COACH
(WITH TWIN BEDS ONLY)
(WIRE ASM 119517)

TITLE:		WIRING DIAGRAM-BODY	
30 NET SCALE DRAWING	SHEET	1	1
SHEET	3	OF	5
DATE		119904	

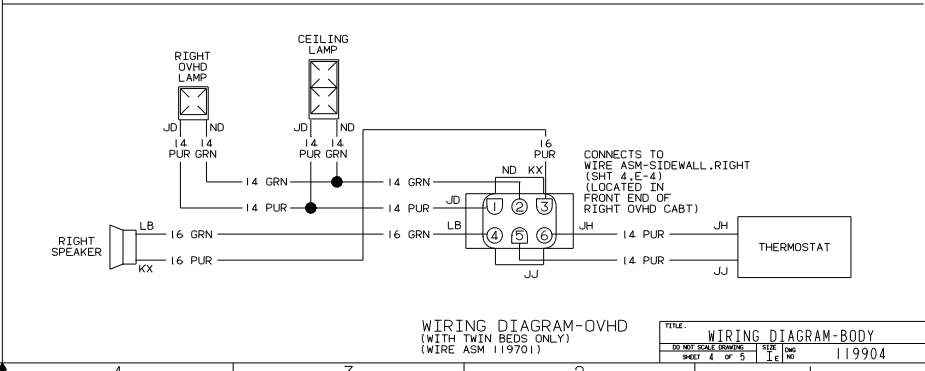
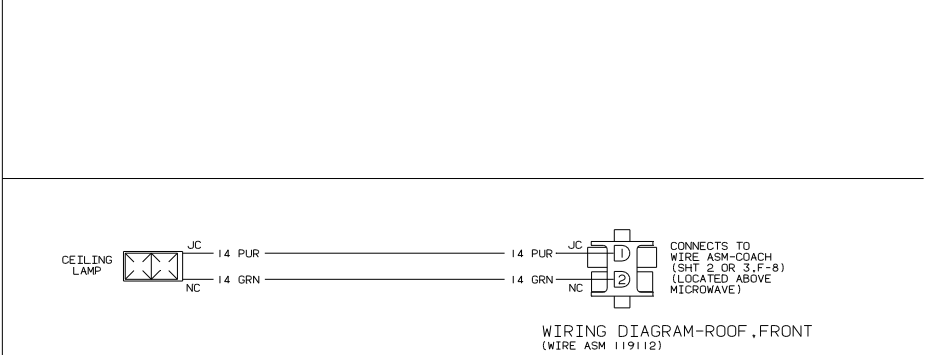
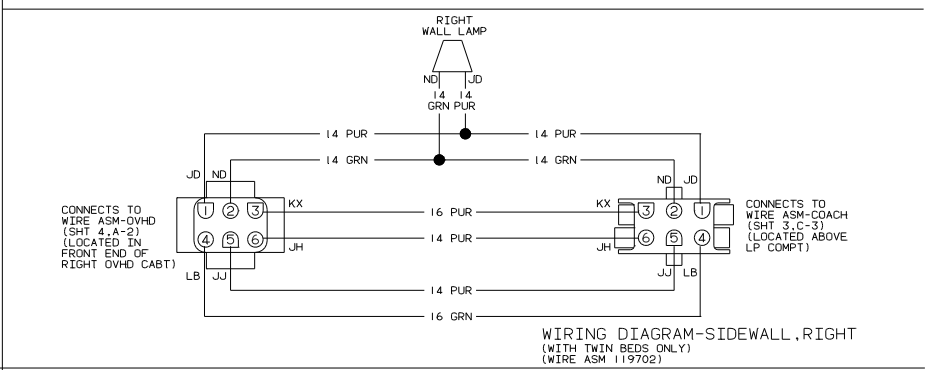
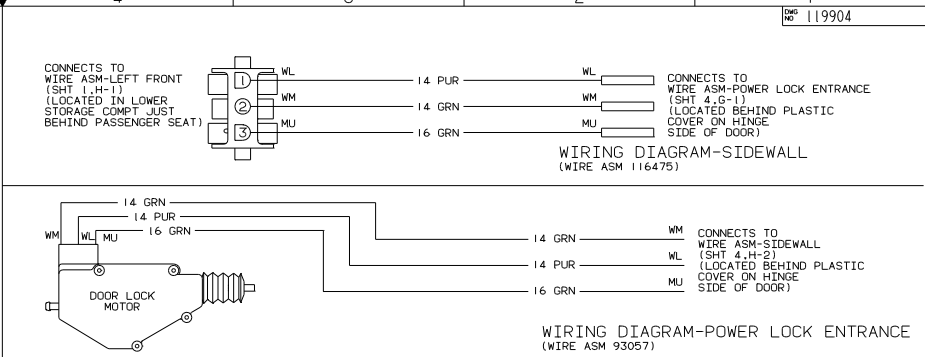
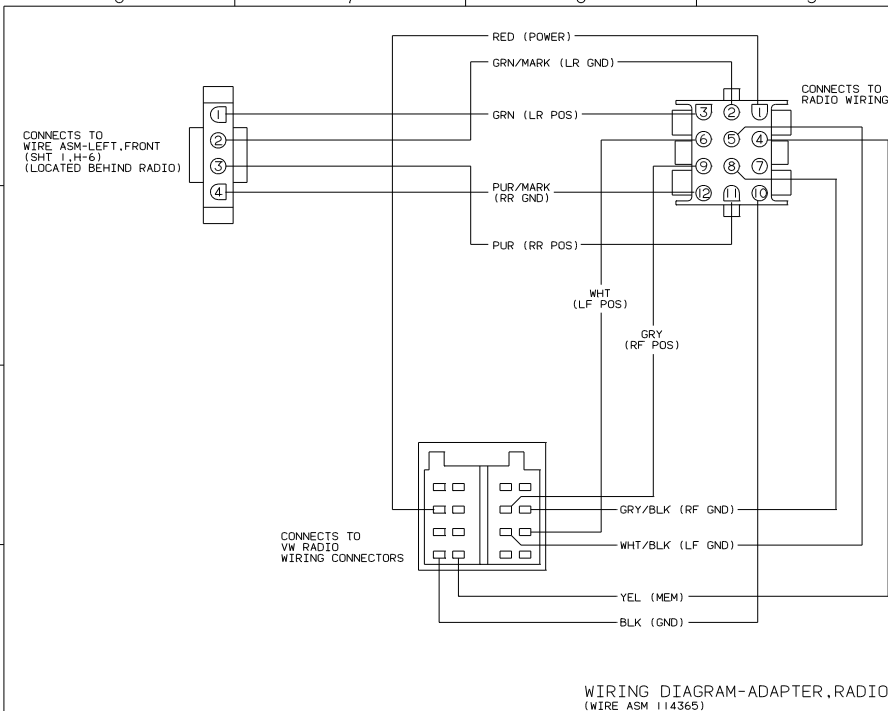

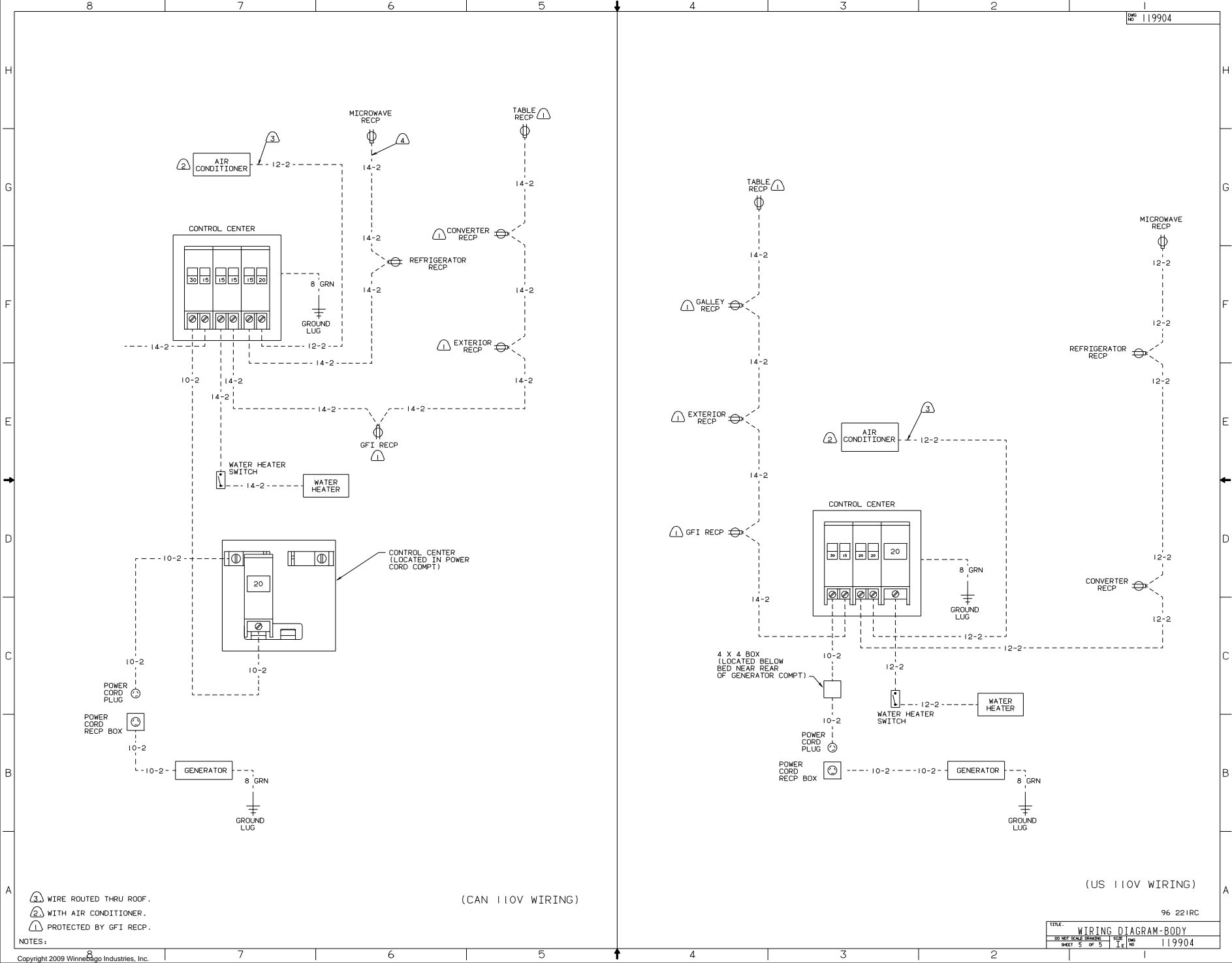

- ③ WIRE ROUTED THRU ROOF.
- ② WITH AIR CONDITIONER.
- ⚠ PROTECTED BY GFI RECP.

NOTES:

(CAN 110V WIRING)

(US 110V WIRING)

96 221RC

TITLE: WIRING DIAGRAM-BODY	
30 NET SCALE DRAWING	1/1
SHEET 5 OF 5	1/1
119904	