

OWNER'S MANUAL

and Installation Instructions

Series NP-30G

AIR-COOLED

RECREATIONAL VEHICLE

GENERATORS

Model No. 0661-3

GENERAC[®]
C O R P O R A T I O N

GENERAL SAFETY RULES

THE MANUFACTURER SUGGESTS THAT THESE "RULES" FOR SAFE OPERATION BE COPIED AND POSTED IN POTENTIAL HAZARD AREAS OF THE RECREATIONAL VEHICLE. SAFETY SHOULD BE STRESSED TO ALL OPERATORS AND POTENTIAL OPERATORS OF THIS EQUIPMENT.

Study these SAFETY RULES carefully before operating or servicing applicable equipment. Become familiar with this Owner's Manual and with your generator. Safe, efficient and reliable operation can only be achieved if generator is properly installed, operated and maintained. Many accidents are caused by failing to follow simple and fundamental rules or precautions. The manufacturer suggests that these GENERAL SAFETY RULES be copied and posted in potential hazard areas of the recreational vehicle. Safety should be stressed to all operators and potential operators of equipment.



WARNING:



The engine exhaust from this product contains chemicals known to the State of California to cause cancer, birth defects, or other reproductive harm.

The manufacturer cannot possibly anticipate every circumstance that might involve a hazard. The warnings in this Manual and on tags and decals affixed to the unit are, therefore, not all-inclusive. If you use a procedure, work method or operating technique Generac does not specifically recommend, you must satisfy yourself that it is safe for you and others. You must also make sure the procedure, work method or operating technique that you chose does not render the generator to be unsafe.

- In case of accident caused by electric shock, shut down the source of electrical power down at once. If this cannot be done, free victim from live conductor. AVOID DIRECT CONTACT WITH THE VICTIM. Use a dry board, dry rope, or other non-conducting implement to free the victim from live conductor.
- Inspect fuel system frequently for leaks or damage. Repair or replace any damaged or leaking component immediately. Never attempt to change, alter or modify the generator fuel system in any way that might affect safety or compliance with applicable codes and standards.
- The generator engine gives off DEADLY carbon monoxide gas through its exhaust system. This dangerous gas, if breathed in sufficient concentrations, can cause unconsciousness or even death. This exhaust system must have been properly installed, in strict compliance with applicable codes and standards. Following installation, you must do nothing that might render the system unsafe or in non-compliance with such codes and standards. The generator compartment must be completely vapor sealed from vehicle interior. There must be no possibility of exhaust fumes entering the vehicle interior. Never operate this equipment with a leaking or defective exhaust system.
- Never use the generator or any of its parts as a step. Stepping on the unit can stress and break parts and may result in dangerous, fuel leakage, oil leakage, etc.
- Do not smoke around the generator. Wipe up any fuel and oil spills immediately. Never leave oily or fuel soaked rags in the generator compartment or on the generator itself. Keep the area around the generator clean and free of debris.
- Adequate ventilation is required to expel toxic fumes and gasoline vapors from the generator compartment. Do not alter the installation of this equipment in any manner that might obstruct air and ventilation openings. Such openings must be kept clear and unobstructed.
- Keep hands, feet, clothing, etc., away from drive belts, fans and other moving parts of this equipment. Never remove any drive belt or fan guards while the unit is operating.
- Inspect the generator periodically. Repair or replace all damaged or defective parts immediately.
- These generators can be converted to use LP gas (propane) as a fuel. LP gas is highly EXPLOSIVE. The gas is heavier than air and tends to settle in low areas where even the slightest spark can ignite the gas and cause an explosion.
- Before performing any maintenance on the generator set, disconnect its battery cables to prevent accidental start up. Disconnect the cable from the battery post indicated by a NEGATIVE, NEG or (-) first. Reconnect that cable last.
- For fire safety, the recreational vehicle generator must be properly installed and maintained. Installation must always remain in compliance with applicable codes and standards. In addition, the generator must be installed in conformance to the manufacturer's detailed installation instructions. Following installation, nothing must be done that might render the generator in noncompliance with such codes, standards and instructions.
- The RV generator produces extremely high and dangerous electrical voltages and can cause dangerous, and possibly fatal, electrical shock. Avoid contact with bare wires, terminals, etc. while the unit is running. If you must work around an operating generator, stand on an insulated, dry surface to reduce shock hazard.
- Never work on this equipment or handle any electrical device while standing in water, while barefoot, or while hands or feet are wet. Dangerous electrical shock will result.
- Have the generator properly grounded (bonded) during installation onto the vehicle, either by solid mounting to the vehicle frame or chassis or by means of an approved bonding conductor. DO NOT disconnect the bonding conductor, if so equipped. DO NOT reconnect the bonding conductor to any generator part that might be removed or disassembled during routine maintenance. If the grounding conductor must be replaced, use only a flexible conductor that is of No. 8 AWG copper wire minimum.

IDENTIFICATION RECORD AND GENERATOR FEATURES

Please record the following information from the generator DATA PLATE or information decal.

- | | |
|-----------------------|------------------------|
| 1. Model Number _____ | 2. Serial Number _____ |
| 3. kW Rating _____ | 4. Rated Voltage _____ |
| 5. Phase _____ | 6. Hertz _____ |

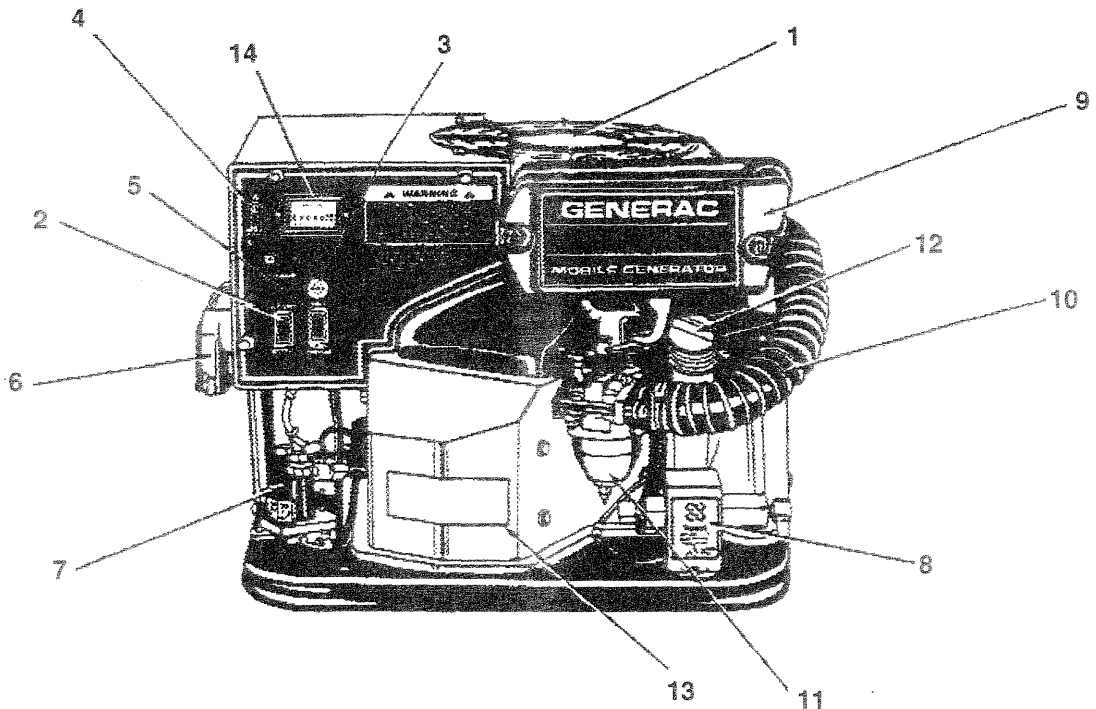

REFERENCE NUMBER IDENTIFICATION

- | | |
|--------------------------------|----------------------------------|
| 1. Generator Air Intake Screen | 8. Fuel Pump |
| 2. Engine Start/Stop Switch | 9. Air Cleaner |
| 3. Fuse | 10. Air Intake Tube |
| 4. Circuit Breaker | 11. Carburetor |
| 5. Fuel Pump Primer | 12. Oil Dipstick and Filler Tube |
| 6. Generator AC Output Leads | 13. Data Decal |
| 7. 12 Volt Battery Connection | 14. Hour Meter |

TABLE OF CONTENTS

OPERATING INSTRUCTIONS

GENERAL SAFETY RULESinside cover

IDENTIFICATION RECORD AND
GENERATOR FEATURES..... 1

READ THIS MANUAL THOROUGHLY

Operation and Maintenance 3
How to Obtain Service 3

GENERATOR FAMILIARIZATION

Generator Applicability 4
Safety 4
Generator AC Connection System 4

OPERATING INSTRUCTIONS

Generator Control Panel..... 5
Automatic Choke 5
Before Starting the Engine 5
Starting 6
Stopping the Generator 6
Applying Loads to Generator..... 6
Attention Required After Submersion 6
Operation in High Grass or Brush 7
Operating Precautions 7
Effects of Moisture and Dirt 7
Don't Overload the Generator..... 7
Automatic Low Oil Pressure Shutdown 7
High Temperature Shutdown..... 7
Overspeed 7
Low Voltage..... 8

SPECIFICATIONS

Fuel Requirements 8
Engine Oil Requirements..... 8
Generator Specifications 8
Engine Specifications 8

MAINTENANCE

Checking Engine Oil Level 9
Change Engine Oil 9
Change Oil Filter..... 9
Engine Air Cleaner 9
Spark Arrestor Muffler 10
Engine Spark Plug..... 10
Fuel Filter..... 10
Cleaning the Generator 10
Battery 10
Service and Adjustments..... 11
Throttle Linkage Adjustment..... 11
Adjusting the Carburetor..... 11
Adjusting Valve Clearance 11
Major Service Manual 12
Exercising the Generator..... 12
Out of Service Protection..... 12
Return the Unit to Service after Storage..... 12

INSTALLATION INSTRUCTIONS

INSTALLATION SAFETY RULES 13

GENERAL INSTALLATION INFORMATION

Purpose of Scope 14
Safety 14
Standards Booklet..... 14
Equipment Description 14
Engine-Generator Operating Speed..... 14
Generator AC Connection System 14

LOCATION AND SUPPORT

Generator Location..... 15
Generator Support..... 15
Suspended Mounting 15
Generator Restraint..... 16

GENERATOR COMPARTMENTS

Compartment Seams 16
Compartment Size..... 17
Compartment Construction 17
Sound Insulation Materials 17
Compartment Floor Cutouts 18
Acoustics' 18

COOLING AND VENTILATION AIR

Generator Air Flow 19
Cooling Air Inlet Openings..... 19
Compensating for Restrictions 20
Testing the Installation 20

GASOLINE FUEL SYSTEM 21

EXHAUST SYSTEM 22

ELECTRICAL CONNECTIONS

Electrical Junction Box 23
Wiring 23
Generator AC Connections 23
Conduit 23
Isolating Different Power Sources 24
Power Supply Cord 24
Ground Fault Circuit Interruptors..... 24

BATTERY INSTALLATION25-26

OPTIONAL ACCESSORIES 27

POST INSTALLATION TESTS 28

INSTALLATION CHECK LIST 29

MAJOR FEATURES AND DIMENSIONS 30

TROUBLESHOOTING 31

ELECTRICAL DATA 32-33

REPAIR PARTS..... 34 to 41

NOTES42-43

CALIFORNIA EMISSIONSWARRANTY44-45

WARRANTYback page

READ THIS MANUAL THOROUGHLY

If you don't understand any portion of this manual, contact Generac for a demonstration of actual starting, operating and servicing procedures.

Throughout this publication and on tags and decals affixed to the generator, DANGER and CAUTION blocks are used to alert you to special instruction about a particular operation that may be hazardous if performed incorrectly or carelessly. Observe them carefully.

These safety warnings cannot eliminate the hazards that they indicate. Strict compliance with the special instructions while performing the service plus "common sense" are major measures to prevent accidents.

The following definitions apply to DANGER, CAUTION and NOTE blocks found throughout the manual.



DANGER: AFTER THIS HEADING YOU CAN READ HANDLING, INSTALLING, OPERATING OR SERVICING INSTRUCTIONS THAT, IF NOT STRICTLY COMPLIED WITH, MAY RESULT IN PERSONAL INJURY.



CAUTION: After this heading you can read instructions for handling, installing, operating or servicing the generator that, if not strictly complied with, may result in damage to equipment and/or property.

NOTE: After this heading you can read explanatory statements that require special emphasis.

These symbols indicate the following:



Points out important safety information and, if not followed, could endanger personal safety and/or property of yourself and others.



Potential explosion hazard



Potential fire hazard



Potential electrical shock hazard

The operator (driver) is responsible for proper and safe use of the vehicle, equipment on the vehicle, and the safety of all vehicle occupants. We strongly recommend that the operator read this Owner's Manual and thoroughly understand all instructions before using this equipment. We also strongly recommend instructing other occupants in the vehicle to properly start and operate the generator. This prepares them if they need to operate the equipment in an emergency.

OPERATION AND MAINTENANCE

It is the operator's responsibility to perform all safety checks; to make sure that all maintenance for safe operation is performed promptly; and to have the equipment checked by an Authorized Dealer periodically. Normal maintenance service and replacement of parts are the responsibility of the Owner/Operator and, as such, are not considered defects in materials or workmanship within the terms of the warranty. Individual operating habits and usage contribute to the need for maintenance service.

Proper maintenance and care of your recreational vehicle generator assures a minimum number of problems and keeps your operating expenses at a minimum. See your authorized Dealer/Distributor for service aids and accessories.

HOW TO OBTAIN SERVICE

When your recreational vehicle generator set requires servicing or repairs, simply contact an Authorized Service Facility for assistance. Service technicians are factory-trained and are capable of handling all of your service needs.

When contacting an Authorized Service Facility or the factory about parts and service, always supply the complete model number and serial number of your unit as given on its data plate.

The warranty on your generator is included in this Owner's Manual, as well as listings for repair parts.

GENERATOR FAMILIARIZATION

GENERATOR APPLICABILITY

These generators have been designed and manufactured for supplying electrical power for recreational vehicles. You should not modify the generator or use it for any application other than for what it was designed. If there are questions pertaining to its application, write or call the factory. Do not use the unit until you have been advised by a competent authority.



DANGER: FOR FIRE SAFETY, THE GENERATOR MUST HAVE BEEN PROPERLY INSTALLED IN COMPLIANCE WITH (1) ANSI 119.2-1975/NFPA 501C-1974 "STANDARD FOR RECREATIONAL VEHICLES", PART III, "INSTALLATION OF ELECTRICAL SYSTEMS." THE GENERATOR ALSO MUST HAVE BEEN INSTALLED IN STRICT COMPLIANCE WITH THE MANUFACTURER'S DETAILED INSTALLATION INSTRUCTIONS. AFTER INSTALLATION, DO NOTHING THAT MIGHT RENDER THE UNIT IN NON-COMPLIANCE WITH SUCH CODES, STANDARDS AND INSTRUCTIONS.

You can use this generator to supply electrical power for operating 120 volts, single phase, 60 Hertz, electrical loads. These loads can require up to 3000 watts (3.0 kW) for the NP-30G.



CAUTION: Do not overload the generator. Some installations may require that electrical loads be alternated to avoid overloading. Applying excessively high electrical loads may damage the generator and may shorten its life. Add up the rated watts of all electrical lighting, appliance, tool and motor loads the generator will power at one time. This total should not be greater than the wattage capacity of the generator. If an electrical device nameplate gives only volts and amps, multiply volts times amps to obtain watts (volts x amps = watts). Some electric motors require more watts of power (or amps of current) for starting than for continuous operation.

SAFETY

Before using the generator set, carefully read GENERAL SAFETY RULES inside the cover. Comply with these RULES to prevent accidents and damage to equipment and/or property. Generac suggests copying and posting the GENERAL SAFETY RULES in potential hazard areas of the recreational vehicle. Safety should be stressed to all operators of this equipment.

GENERATOR AC CONNECTION SYSTEM

This air-cooled NP Series generator can power 120-volt, 60 Hertz AC loads. The diagram below is a simple schematic (Figure 1) of the generator's AC connection system.

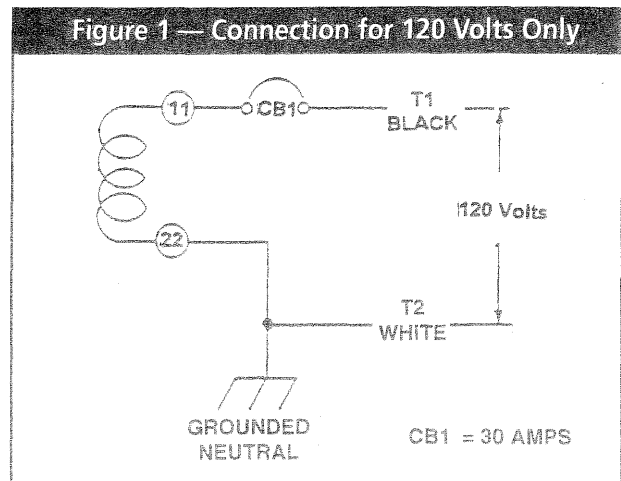

OPERATING INSTRUCTIONS

GENERATOR CONTROL PANEL

Mounted on the generator control panel (Figure 2) are the following features:

FUEL PUMP PRIMER

Before starting a cold engine (it has not been started in more than two weeks), you must press this switch to bring fuel from the tank to the fuel pump. This rocker type switch springs back into its original position when you release it.

START/STOP SWITCH

To crank and start the engine, hold this switch at its START position. Release the switch when the engine starts. To stop an operating engine, place the switch in its STOP position. The switch center position is the RUN position.

FUSE

Protects the engine DC control circuit against electrical overload. If the fuse element has melted open due to overloading, the engine cannot be cranked. If you must replace it, use only an identical replacement fuse.

LINE BREAKER

Protects generator's AC output circuit against overload, i.e., prevents unit from exceeding wattage/ampere capacity.

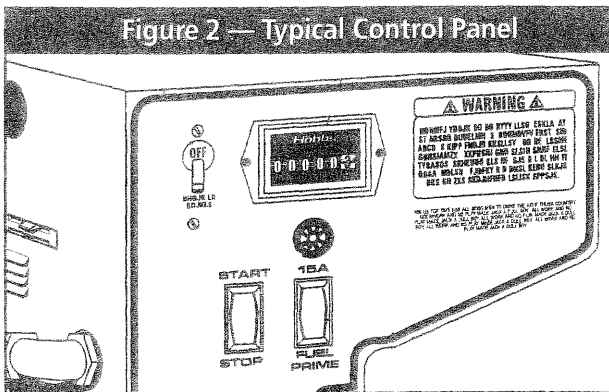

Figure 2 — Typical Control Panel

AUTOMATIC CHOKE

The engine is equipped with an automatic choke that consists of two main components — choke solenoid and prechoke.

CHOKE SOLENOID

During engine cranking (start/stop switch at START), a solid state choke module signals the choke solenoid to actuate and cycle (choke on/choke off) until engine starts. The choke solenoid thus opens and closes the carburetor choke valve only when the engine is cranking. When the engine starts, the choke cycling stops.

PRECHOKE

The choke system also has a temperature sensitive metal strip that adjusts the choke valve angle according to ambient temperatures (i.e., in cold ambient temperatures the choke valve closes more). Once the engine starts, an element heats the temperature-sensitive strip to a normal operating condition, opening the choke valve. This may take about 3 minutes in cooler weather.

BEFORE STARTING THE ENGINE

IMPORTANT: INSTRUCTIONS AND INFORMATION IN THIS MANUAL ASSUME THE GENERATOR HAS BEEN PROPERLY INSTALLED, CONNECTED, SERVICED, TESTED AND ADJUSTED BY A QUALIFIED INSTALLATION TECHNICIAN OR INSTALLATION CONTRACTOR.

INSTALLATION

Generator installation must have been properly completed so it complies with all applicable codes, standards and regulations and with the manufacturer's recommendations.

ENGINE LUBRICATION

Have engine crankcase properly serviced with recommended oil before starting. Refer to "Maintenance" and "Specifications" sections for oil servicing procedures and recommendations.

CAUTION: Any attempt to crank or start the engine before you have properly serviced it with the recommended oil may result in engine failure.

FUEL SUPPLY

The engine must have adequate supply of proper fuel to operate. Before starting, check that sufficient fuel is available.

NOTE: On some installations, the generator engine may "share" the vehicle's gasoline fuel tank with the vehicle engine. Some installations may provide separate fuel tanks for generator and vehicle engine.

COOLING AND VENTILATING AIR

Air inlet and outlet openings in the generator compartment must be open and unobstructed for continued proper operation. Without sufficient cooling and ventilating air flow, the engine-generator quickly overheats, which causes it to quickly shutdown. Overheating could also damage the unit or your vehicle.

■ ENGINE EXHAUST GAS

Before starting the generator engine, you should be sure there is no way for exhaust gases to enter the vehicle interior and endangering people or animals. Close windows, doors and other openings in the vehicle that, if open, might permit exhaust gases to enter the vehicle.



DANGER: THE GENERATOR ENGINE GIVES OFF DEADLY CARBON MONOXIDE GAS THROUGH ITS EXHAUST SYSTEM. THIS DANGEROUS GAS, IF BREATHED IN SUFFICIENT CONCENTRATIONS, CAN CAUSE UNCONSCIOUSNESS OR EVEN DEATH. DO NOT OPERATE THE GENERATOR IF ITS EXHAUST SYSTEM IS LEAKING OR HAS BEEN DAMAGED. SYMPTOMS OF CARBON MONOXIDE POISONING ARE (A) INABILITY TO THINK COHERENTLY, (B) VOMITING, (C) TWITCHING MUSCLES, (D) THROBBING TEMPLES, (E) DIZZINESS, (F) HEADACHE, (G) WEAKNESS AND SLEEPINESS. IF YOU FEEL ANY OF THESE SYMPTOMS, MOVE INTO FRESH AIR IMMEDIATELY. IF SYMPTOMS PERSIST, GET MEDICAL HELP.

STARTING

IMPORTANT: Read the vehicle manufacturer's instructions. The owner/operator should become familiar with the vehicle in which this generator is installed. Differences exist between vehicles. For example, some vehicles may use a transfer switch to isolate dockside power from the generator, while other vehicles may use an isolating receptacle. Some vehicles may be equipped with a DC converter which allows the generator to power certain DC lighting and other DC loads.

To crank and start the generator engine, proceed as follows:

1. Turn OFF electrical loads, using whatever means provided in your vehicle (such as a main line circuit breaker or transfer switch).

NOTE: If you start the engine with the start/stop switch on the generator control panel, turn OFF loads by setting the panel's main breaker to its "OFF" or "OPEN" position. Electrical load circuits can be turned ON after the generator has started, stabilized and warmed up.

NOTE: You only need to use the fuel pump primer during the initial startup, after the unit has not been used for an extended period of time (two weeks) or the fuel line has been disconnected. The primer is used to disengage the fuel pump's automatic shut-off feature.

2. To crank and start the engine, hold the start/stop switch at START. Release the switch when the engine starts.



CAUTION: If the engine does not start after it has been cranking for 15 seconds, release the start/stop switch and try again. Holding the switch for longer than 15 seconds may damage the starter motor.

3. Let the engine run at no-load for a few minutes to stabilize and warm up the engine.
4. Turn ON electrical loads, using whatever means provided (such as a main circuit breaker or transfer switch).

NOTE: If you start a warm generator engine, you may press the start switch only slightly to engage the ignition system.

STOPPING THE GENERATOR

1. Turn OFF all electrical loads, using whatever means provided (such as a main circuit breaker or transfer switch).
2. Let the generator run at no-load for a few minutes, to stabilize internal engine-generator temperatures.
3. Place Start/Stop switch in its STOP position.

APPLYING LOADS TO GENERATOR

When applying electrical loads to the generator, observe these guidelines:

- Before applying electrical loads, let the generator stabilize and warm up for a minute or two.
- DO NOT overload the generator.

■ LETTING ENGINE STABILIZE

The generator supplies correct rated frequency and voltage only at the proper governed speed. Some electrical appliances may be extremely sensitive to voltage and frequency. Incorrect frequencies and/or voltages can damage those appliances.

If electrical loads are applied at reduced operating speeds, such loads imposed on the engine when sufficient power is not available may shorten engine life. Never turn ON electrical loads until after the generator engine has started and stabilized ON-speed.

ATTENTION REQUIRED AFTER SUBMERSION

If the motor home generator has been submerged in water, it must NOT be started or operated. Following any submersion in water, have an authorized Generac Service Facility thoroughly clean and dry the generator.

OPERATION IN HIGH GRASS OR BRUSH

Never operate the generator while the vehicle is parked in high grass, weeds, brush or leaves. Such materials can ignite and burn from the heat of the exhaust system. The generator exhaust system becomes extremely hot during operation and remains hot for a long time after it has shut down.

OPERATING PRECAUTIONS

Never operate the motor home generator set while the vehicle is parked over dry leaves, dry grass or any other combustible substance. The generator's exhaust system becomes extremely hot and can cause fire if it is too close to combustible materials.

The generator's exhaust system gives off DEADLY carbon monoxide gas. This dangerous gas, if breathed in sufficient concentrations, can cause unconsciousness and even death. Never operate the generator set with the vehicle inside any garage or other enclosed area. Never operate the generator if it has a leaky exhaust system. Close windows in the vicinity of the generator exhaust outlet and take any other steps to prevent exhaust gases from entering rooms or areas occupied by people or animals.

EFFECTS OF MOISTURE AND DIRT

Keep the generator set as clean and dry as possible. Protect unit against excessive dust, dirt, corrosive vapors, road splash, etc. Permitting dirt and moisture to accumulate on generator windings will have an adverse effect on the insulation resistance of those windings.

When moisture is allowed to remain in contact with windings, some of the moisture will be retained in voids and cracks in the insulation. This causes a reduced insulation resistance and will eventually cause problems. Dirt will make the problem worse, since dirt tends to hold moisture in contact with windings. Salt (as from sea air) will also worsen the problem since it tends to absorb moisture from the air. Salt and moisture, when combined, form a good electrical conductor.

DO NOT OVERLOAD THE GENERATOR

You can read the rated wattage/ampere capacity of your generator on the generator data decal (see "Identification Record" on Page 1).

Applying electrical loads in excess of the unit's rated capacity will cause the engine-generator to automatically shutdown.

To avoid overloading, add up the wattage of all connected electrical lighting, appliance, tool and motor loads. This total should not be greater than the generator's rated wattage capacity.

- Most lighting, appliance, tool and motor loads indicate their required watts on their nameplate or data decal. For light bulbs, simply note the wattage rating of the bulb.

- If a load does not show its rated wattage, multiply that load's rated VOLTS times AMPS to obtain WATTS.
- Induction type motors (such as those that run the vehicle's furnace fan, refrigerator, air conditioner, etc.) need about 2-1/2 times more watts of power for starting than for running (for a few seconds during motor starting). Be sure to allow for this when connecting electrical loads to the generator. First, figure the watts needed to start electric motors in the system. To that figure, add the running wattages of other items that will be operated by the generator.
- On a new generator do not apply heavy electrical loads for the first two or three hours of operation.

AUTOMATIC LOW OIL PRESSURE SHUTDOWN

The engine is equipped with an oil pressure sensor that shuts down the engine automatically when oil pressure is too low. If the engine shuts down by itself and the fuel tank has enough gasoline, check the engine oil level.

■ INITIAL STARTUP

During initial startup, a time delay built into the shutdown control system allows oil pressure to build. The delay allows the engine to run for about 10 seconds before sensing oil pressure.

■ SENSING LOW PRESSURE

If the system senses low oil pressure during operation, the engine shuts down. If you do restart the engine after a low oil shutdown and have not corrected the low oil pressure, the engine runs for about 10 seconds as described above then stops.

HIGH TEMPERATURE SHUTDOWN

An oil temperature switch with normally-open (N.O.) contacts is mounted near the oil filter. If oil temperature were to exceed a preset temperature, the switch contacts close and the engine shuts down.

OVERSPEED

If engine speed is increased manually (or otherwise) beyond the control of the computer control system, the computer disables the load capability of the generator and shuts down the engine.



WARNING: DO NOT ATTEMPT A MANUAL ADJUSTMENT TO CONTROL THE ENGINE SPEED. EQUIPMENT DAMAGE OR PERSONAL INJURY MAY RESULT.

SPECIFICATIONS

LOW VOLTAGE

The computer monitors the voltage output of the generator. If voltage sensors indicate that voltage has dropped below a preset level, the engine will automatically shut down. Once the unit has shutdown, the computer is automatically reset when you restart the engine.

NOTE: The computer allows for the low voltage output that occurs during startup. A time delay that allows the engine to start and warm up is programmed into monitoring the system.



CAUTION: Before restarting a generator that has been shutdown, disconnect all loads the generator might power by whatever means provided, such as the recreational vehicle's main circuit breaker.

FUEL REQUIREMENTS

These generators are equipped with gasoline fuel systems as standard equipment. Specific installations may provide either a separate fuel tank for the generator, or the generator may "share" the vehicle engine's fuel tank.

NOTE: Installations using a "shared" fuel tank may have a generator fuel pickup tube that is shorter than the vehicle engine's pickup tube. Such an arrangement causes the generator engine to "run out of gas" while adequate fuel for the vehicle remains in the tank.

To reduce lead and carbon deposits use high quality UNLEADED gasoline with the generator. Leaded REGULAR grade gasoline is an acceptable substitute.

NOTE: Using "Unleaded" gasoline contributes to longer engine valve life by reducing lead and carbon deposits.



CAUTION: Generac does not recommend using any gasoline containing alcohol, it must not contain more than 10 percent ethanol and it must be removed from the tank during storage. Do NOT use any gasoline containing methanol. If you use gasoline with alcohol, inspect more frequently for fuel leaks and other abnormalities.

ENGINE OIL REQUIREMENTS

Use only high quality detergent oil rated with API service classification SF, SG or SH. The recommended oil weights include the following:

- During summer months: SAE 30. An acceptable substitute is SAE 10W-30.
- During winter months: SAE 5W30. DO NOT USE SAE 10W-40.

Crankcase and oil filter capacity is about 950ml or about 1 U.S. quart. Use no special additives. See "Maintenance" section for oil level check and fill procedures.

GENERATOR SPECIFICATIONS

Model	NP-30G
Rated Maximum Continuous	
AC Power Output	3000 watts (3.0 kW)
Rated Voltage	120 volts AC
Rated Maximum Continuous	
Current at 120 volts	25 AC amperes
Phase	Single Phase
Rated AC Frequency	60 Hz.

ENGINE SPECIFICATIONS

Type of Engine	GN-220
Cooling Method	Air-cooled
Displacement	220cc
Type of Governor	Electronic
Air Cleaner	Paper element
Starter	12 volts DC electric
Ignition System	Solid state
Recommended Spark Plugs	
Champion	RC12YC
Spark Plug Gap	0.030 inch (0.8mm)

This section includes information about simple maintenance which includes the following tasks:

- Checking engine oil level.
- Changing engine oil.
- Changing oil filter.
- Changing the air cleaner.
- Cleaning the air intake screen.
- Cleaning spark plugs.

CHECKING ENGINE OIL LEVEL

Check engine crankcase oil level at least every eight hours of operation, or before each use (Figure 3).

- Be sure the generator is as level as possible.
- Remove oil dipstick and wipe dry with clean, lint-free cloth.
- Install and tighten oil dipstick, then remove again.
- Oil should be at dipstick FULL mark. If necessary, add the recommended oil to the FULL mark only. **DO NOT FILL ABOVE "FULL" MARK.**
- Install and tighten oil dipstick cap before operating the engine.

NOTE: See "Engine Oil Requirements" on Page 8 for recommended oils.

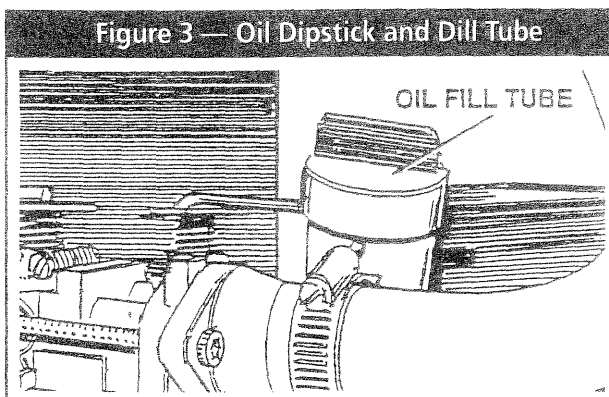

CHANGE ENGINE OIL

Change engine oil after the first 8 hours of operation. Thereafter, change oil every 50 operating hours. Change oil more frequently if operating consistently under heavy load or at high ambient temperatures.

- Warm up engine for at least five minutes, then shut down.
- With engine still warm from running, clean area around oil drain plug and remove oil drain plug (Figure 4). Drain oil completely into a suitable container.
- When oil has drained, install and tighten drain plug.
- Remove oil dipstick and fill crankcase with the recommended oil (See Page 8). The engine crankcase can hold about 1 quart (950ml). **DO NOT FILL ABOVE "FULL" MARK.**

- Install and tighten dipstick cap before operating engine.

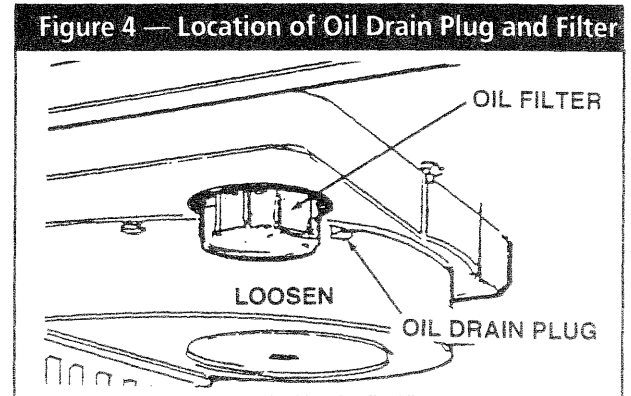

CHANGE OIL FILTER

Replace the engine oil filter after the first 8 hours of operation, every 50 operating hours thereafter.

- Turn oil filter counterclockwise to remove (Figure 4).
- Coat gasket of new filter with engine oil.
- Turn new filter clockwise until its gasket contacts tightly with the filter adapter. Then tighten with an additional 3/4 to one turn by hand.
- Run engine and check for leaks.

NOTE: Check the oil level and fill to FULL mark on dipstick after checking for leaks. The filter will retain some oil.

ENGINE AIR CLEANER

Paper Filter: Once every 25 operating hours or once each year (whichever comes first), clean or replace the paper filter (Figure 5). Follow these steps:

- Remove air cleaner cover, then remove paper filter.
- Clean air filter by gently tapping it on a solid surface. If the filter is too dirty, replace it with a new one. Dispose of the old filter properly.
- Clean air cleaner cover then insert new paper filter into cover and assemble them to the base of the air cleaner.

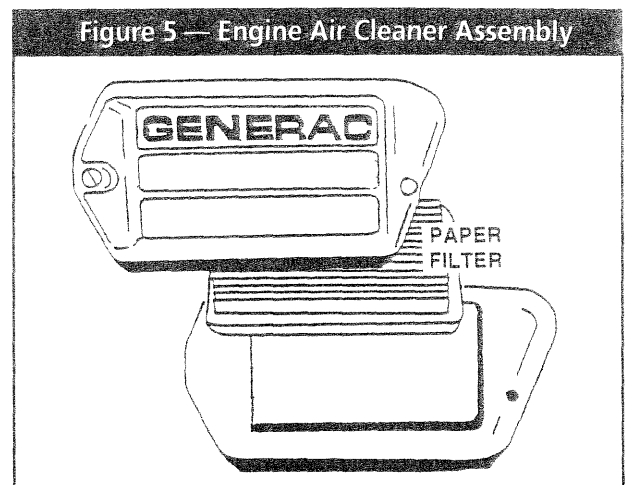

SPARK ARRESTOR MUFFLER

The spark arrestor must be maintained in effective working order by the vehicle owner/operator.

In the State of California, the preceding is required by law (Section 4442 of the California Public Resources Code). Other states may have similar laws. Federal laws apply on federal lands.

Inspect and clean the spark arrestor every 100 hours of operation.

To remove the spark arrestor, remove the exhaust tubing connected to the muffler and then remove the screw that attaches the arrestor to the muffler. Replace the cone-shaped spark arrestor if torn, perforated or otherwise damaged.

ENGINE SPARK PLUG

Clean or replace engine spark plug and set gap to 0.030 inch (0.76mm) every 100 hours of operation (Figure 6). Clean by scraping or wire brushing and washing with commercial solvent. **DO NOT BLAST CLEAN SPARK PLUG.**

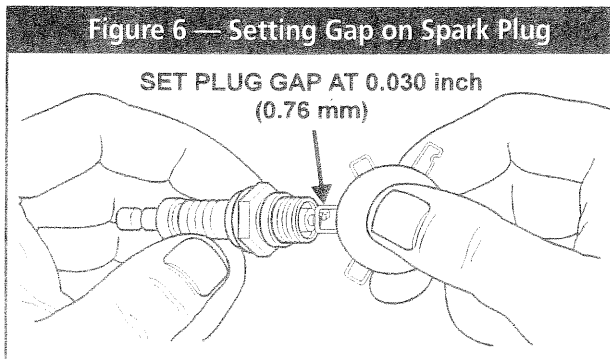

CAUTION: Sparking can occur if wire terminal does not fit firmly over spark plug terminal end. If necessary, reform wire terminal to obtain a tight fit.

FUEL FILTER

Remove and replace fuel filter (Figure 7) every 100 hours of operation or once each year, whichever occurs first.

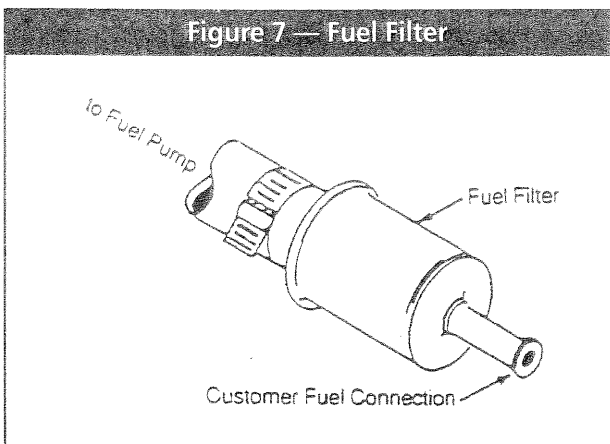

CLEANING THE GENERATOR

Keep your generator set as clean and dry as possible. Dirt and moisture that are permitted to accumulate on electrical windings have an adverse affect on the insulation resistance of those windings.

Moisture that is allowed to remain in contact with windings will be retained in voids and cracks of the windings. Dirt makes the problem worse, since it tends to hold the moisture into contact with the windings. Salt, as from sea air, worsens the problem since it tends to absorb moisture from the air. The combination of salt and moisture makes a good electrical conductor.



CAUTION! Do NOT use a forceful spray of water to clean the generator. Water will enter the generator interior and cause problems, and may also contaminate the generator fuel system.

BATTERY

All lead-acid storage batteries will discharge when not in use. Inspect the generator battery as follows:

■ ONCE WEEKLY

Inspect battery posts and cables for tightness, corrosion. Clean and/or tighten as necessary.

Also check battery fluid level, and, if necessary, fill with **DISTILLED WATER ONLY. DO NOT USE TAP WATER IN BATTERY.**

■ EVERY SIX MONTHS

Have the battery state of charge and condition checked by an automotive service facility. This should be done with an automotive type battery hydrometer.



DANGER: STORAGE BATTERIES GIVE OFF EXPLOSIVE HYDROGEN GAS. THIS GAS CAN FORM AN EXPLOSIVE MIXTURE AROUND THE BATTERY FOR SEVERAL HOURS AFTER CHARGING. THE SLIGHTEST SPARK CAN IGNITE THE GAS AND CAUSE AN EXPLOSION. SUCH AN EXPLOSION CAN SHATTER THE BATTERY AND CAUSE BLINDNESS OR OTHER INJURY. ANY AREA THAT HOUSES A STORAGE BATTERY MUST BE PROPERLY VENTILATED. DO NOT ALLOW SMOKING, OPEN FLAME, SPARKS OR ANY SPARK PRODUCING TOOLS OR EQUIPMENT NEAR THE BATTERY.



DANGER: BATTERY ELECTROLYTE FLUID IS AN EXTREMELY CAUSTIC SULFURIC ACID SOLUTION THAT CAN CAUSE SEVERE BURNS. DO NOT PERMIT FLUID TO CONTACT EYES, SKIN, CLOTHING, PAINTED SURFACES, ETC. WEAR PROTECTIVE GOGGLES, PROTECTIVE CLOTHING AND GLOVES WHEN HANDLING A BATTERY. IF YOU SPILL THE FLUID, FLUSH THE AFFECTED AREA IMMEDIATELY WITH CLEAR WATER.



DANGER: DO NOT USE ANY JUMPER CABLES OR BOOSTER BATTERY TO CRANK AND START THE GENERATOR ENGINE. IF ANY BATTERY HAS DISCHARGED, REMOVE IT FROM THE VEHICLE FOR RECHARGING.



CAUTION: Do not overbend the spring clip or the clip will lose its clamping force.

SERVICE AND ADJUSTMENTS

ENGINE SPEED

Engine speed is completely computer-controlled. There is no adjustment for speed on the unit. The computer adjusts the engine speed using an electronic governor throttle control. The computer monitors the demand for power and adjusts the engine speed accordingly. This allows the engine to produce only the power required, resulting in fuel economy as well as lowering the overall noise emitted.

NOTE: The computer will disable the electrical load capabilities of the generator and enter a fault condition if you accelerate the throttle manually or any other way.

THROTTLE LINKAGE ADJUSTMENT

If needed, you can adjust the length of the linkage rod between the electronic governor lever arm and the carburetor throttle lever arm. This adjustment helps to establish the proper travel relationship between the two lever arms. If this adjustment is not properly set, the computer will NOT have control of the full range of engine speed. If the rod adjustment is set too short, the computer will not have access to wide open throttle or "full power" conditions. If the rod adjustment is set too long, the computer will not have access to closed throttle or "no power" conditions.

Use the following procedure to assure the linkage rod is properly adjusted:

1. Start the generator, then shut it down right away. As the engine coasts to a stop, observe from above the engine as the throttle lever on the carburetor rotates counter-clockwise.
2. There should be a gap of 0.003 inch (0.08-0.5mm) between stop tab on throttle lever arm and the stop block on the carburetor die casting (Figure 8).

Figure 8 — Gap Between Stop Tab and Stop Block

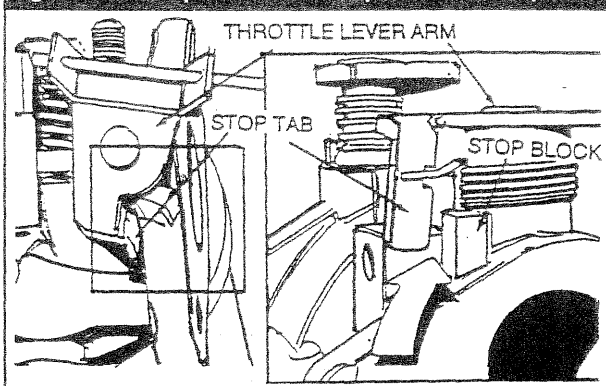

3. With pliers, lightly compress the spring clip on the carburetor lever arm. This allows the linkage rod to slide freely through the clip. While the clip is compressed, rotate the throttle lever in the appropriate direction to increase or decrease the gap until there is 0.003 inch (0.08-0.5mm) clearance (Figure 9).

Figure 9 — Adjusting Throttle Linkage

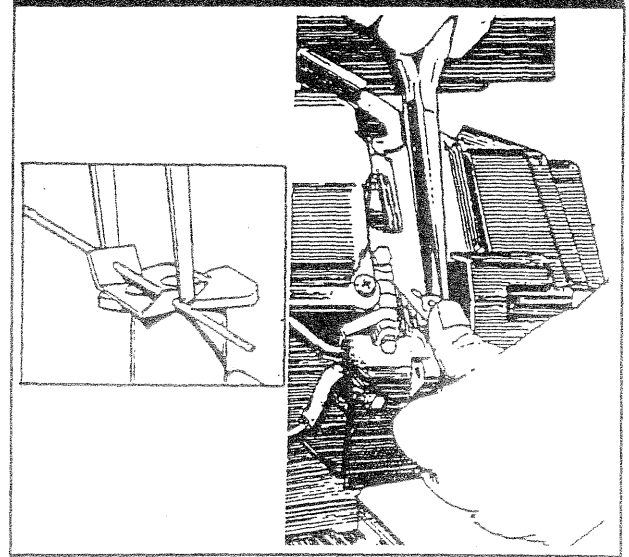

4. Release spring clip so you can secure adjustment. This allows the carburetor and the electronic governor to be synchronized.

ADJUSTING THE CARBURETOR

The carburetor of your generator is preset at the factory. The carburetor should not be tampered with, as this will void the emission control system warranty. If your generator is used at altitudes in excess of 5000 feet, consult your Generac Authorized Service Facility regarding high altitude jetting changes.

ADJUSTING VALVE CLEARANCE

After the first 50 hours of operation, you should adjust the valve clearance in the engine.

When adjusting valve clearance, the engine should be at room temperature and the piston should be at Top Dead Center (TDC) of its compression stroke (both valves closed). Correct clearance is 0.001-0.003 inch (0.03-0.07mm). Adjust valve clearance as follows:

1. Loosen the rocker arm jam nut. Use an allen wrench to turn the pivot ball stud while checking clearance between the rocker arm and the valve stem with a feeler gauge (Figure 10 on page 12).

Figure 10 — Adjusting Valve Clearance

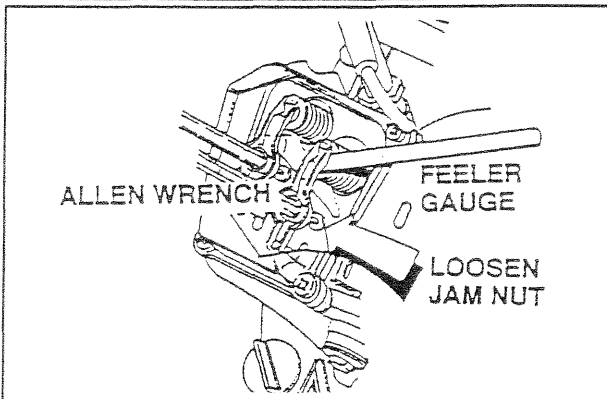

2. When valve clearance is correct, hold the pivot ball stud with the allen wrench and tighten the rocker arm jam nut with a crows foot. Tighten the jam nut to 65-85 inch-pounds torque. After tightening the jam nut, recheck valve clearance to make sure it did not change (Figure 11).

Figure 11 — Tightening Jam Nut

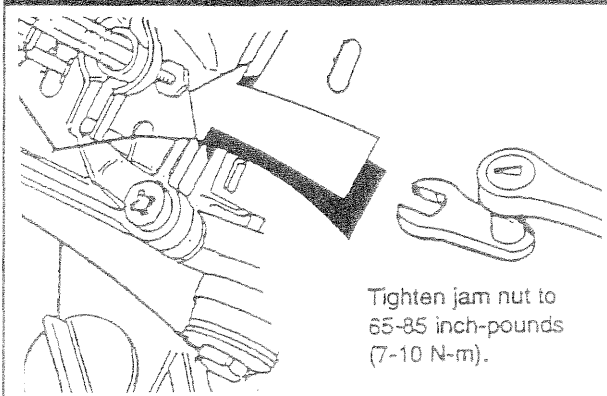

To obtain a service manual for your generator, order it from your dealer/distributor or contact the factory. Be sure to identify your unit's MODEL NUMBER and SERIAL NUMBER.

EXERCISING THE GENERATOR

Generac recommends that you start and operate the generator at least once every seven days. Let the unit run for at least 30 minutes to "exercise" the engine.

OUT OF SERVICE PROTECTION

If you cannot exercise the generator every seven days and it is to be out of service longer than 30 days, prepare the generator for storage as follows:

- Start the engine and let it warm up.
- While the engine is still warm from running, drain the oil completely. Refill crankcase with recommended oil. See "Specifications."
- Attach a tag to the engine indicating the viscosity and classification of the oil in the crankcase.
- Remove spark plug and add about 1/2 ounce (15ml) of clean, fresh engine oil into spark plug threaded openings. Crank engine several times to distribute oil, then install and tighten spark plug.
- Remove the battery and store in a cool, dry room on a wooden board. Never store the battery on any concrete or dirt floor.
- Clean and wipe the entire generator.

RETURN UNIT TO SERVICE AFTER STORAGE

To return the unit to service after storage, proceed as follows:

- Check tag on engine for oil viscosity and classification. Verify that the correct recommended oil is used in engine. If necessary, drain and refill with proper oil.
- Check battery. Fill all cells to the proper level with distilled water. **DO NOT USE TAP WATER IN THE BATTERY.** Recharge battery to 100% state of charge, or, if defective, replace the battery.
- Turn OFF all electrical loads, then start the engine.
- Let engine warm up.
- Apply electrical loads to at least 50% of the unit's rated wattage capacity.
- When engine is thoroughly warmed up, shut it down.

THE GENERATOR IS NOW READY FOR SERVICE.

SERVICE DEALER LOCATION

TO LOCATE THE NEAREST GENERAC SERVICING DEALER, PLEASE CALL OUR 800 NUMBER.

ONLY DEALER LOCATION INFORMATION CAN BE OBTAINED AT THIS NUMBER:

1-800-333-1322

INSTALLATION SAFETY RULES



DANGER: FOR FIRE SAFETY, INSTALLATION OF A GENERATOR INTO A RECREATIONAL VEHICLE MUST COMPLY STRICTLY WITH ARTICLE 551, NFPA 70; ANSI C1-1975; AND, ANSI A119.2-1975/NFPA 501C "STANDARD FOR RECREATIONAL VEHICLES" (PART 3, "INSTALLATION OF ELECTRICAL SYSTEMS"). IN ADDITION, THE MANUFACTURER'S INSTRUCTIONS AND RECOMMENDATIONS MUST BE COMPLIED WITH.



NOTICE TO INSTALLER

The Installation Instructions have been published by Generac Corporation to aid in the installation of the products described in this manual. Generac assumes that installation personnel are familiar with the procedures for installing such products, or similar products that Generac manufactures. Generac also assumes that personnel have been trained in the recommended installation procedures for these products and that such training includes (a) use of common hand tools, (b) use of special Generac tools, and (c) use of any tools and/or equipment from other suppliers.

We could not possibly know of and advise the recreational vehicle trade of all conceivable methods, procedures or techniques by which to perform an installation. We could not know of the possible hazards that might result from each installation method, procedure or technique. We have not undertaken any such wide evaluation. Therefore, people who use a method, procedure or technique that Generac does not specifically recommend must first completely satisfy themselves that their safety, the safety of the vehicle's occupants and the products's safety is not endangered by the method, procedure or technique selected.

Information, illustrations, specifications, etc., contained in this Installation Manual are based on the latest information available at the time of publication. Every effort has been expended to be sure that such data is both accurate and current. However, the manufacturer reserves the right to change, alter or otherwise improve this product at any time without prior notice.

SAFETY RULES

- ▲ Gasoline is extremely **FLAMMABLE** and its vapors are **EXPLOSIVE**. Do not permit smoking, open flame, sparks or any source of heat in the vicinity while handling gasoline. Comply with all laws governing the storage and handling of gasoline.
- ▲ Fuel lines must be properly installed, properly fastened and free of leaks. There must be no possibility of gasoline vapors entering vehicle interior.
 - You are required to install an approved, flexible, non-conductive fuel line between the generator fuel connection point and rigid fuel lines.
- ▲ If the generator can be equipped with a liquid propane (LP) gas fuel system, install the unit so it complies with all codes, standards and regulations pertaining to such systems. LP gas is highly explosive. The gas tends to settle in low areas where even the slightest spark can ignite it and cause an explosion. Do not allow gas vapors to enter the vehicle.
 - Engine exhaust gases contain **DEADLY** carbon monoxide gas. This dangerous gas, if breathed in sufficient concentrations, can cause uncon-

sciousness or even death. Install the exhaust system in strict compliance with applicable codes, standards and regulations. There must be no possibility for exhaust gases entering the vehicle interior and endangering people or animals.

- The generator set produces dangerously high electrical voltage. Contact with bare wires, bare terminals, etc., will result in extremely hazardous and possibly lethal electrical shock.
- All applicable electrical codes, standards and regulations must be strictly complied with in the installation and use of this equipment.
- The generator must be properly grounded (bonded) to the vehicle chassis or frame.
- ▲ If the vehicle electrical circuits can be powered by any other source of electricity (such as a "dockside" power receptacle), there must be no possibility of connecting the different power sources to the vehicle circuits at the same time. The "dockside" (utility) power source must be positively isolated from the vehicle circuits whenever the generator is operating. Failure to isolate the vehicle circuits from the dockside power supply when the generator is running may result in damage to the generator or serious injury or death to dockside (utility) power workers due to backfeed of electrical energy.
 - Never work on the equipment while standing in water, while barefoot, or while hands or feet are wet. Dangerous electrical shock will result.
 - Jewelry conducts electricity, which can cause dangerous electrical shock. Remove all jewelry (such as rings, watches, or bracelets) before working on this equipment.
 - The generator requires an adequate flow of air for cooling and ventilation. Without sufficient cooling air flow, the engine-generator quickly overheats, which causes serious damage to the generator, a fire or an explosion. Generator air inlet and outlet openings must be provided in strict compliance with the manufacturer's recommendations.
 - Never work on this equipment while physically or mentally fatigued. Stay alert at all times.
- ▲ Storage batteries give off **EXPLOSIVE** hydrogen gas while charging. The battery used for cranking and starting this generator should be installed in its own vented compartment. Provide adequate ventilation for the battery, to prevent explosive hydrogen gas from accumulating.
 - Never insert any tool or other object through openings in the generator interior, even if the unit is not running. You might seriously injure yourself or damage the equipment.
 - Staying alert and using "common sense" are major measures for preventing accidents.

GENERAL INSTALLATION INFORMATION

PURPOSE AND SCOPE OF MANUAL

These Installation Instructions have been prepared especially for the purpose of familiarizing installers and owners of the applicable equipment with the product's installation requirements. Give serious consideration to all information and instructions in the Manual, both for safety and for continued reliable operation of the equipment.

Because of the different recreational vehicle models and the variations between the models, it would be extremely difficult, if not impractical, to provide detailed instructions on every installation possibility. For that reason, instructions and illustrations in this manual are general in nature. Illustrations are not intended to serve as detailed installation blueprints.

The installation should comply strictly with all applicable codes, standards and regulations pertaining to the installation and use of this product. If any portion of this manual appears to be in conflict with such codes, standards or regulations, the applicable codes, standards or regulations must take precedence over the manual.

SAFETY

Before handling, installing, operating or servicing this equipment, be sure to read carefully the ©Notice to Installer[®] and "Safety Rules" at front of this manual. Comply with all SAFETY RULES to prevent death, personal injury or damage to equipment and/or property. Stress safety to all installers, operators and service technicians who work on this equipment.

STANDARDS BOOKLETS

Installation, use and servicing of this equipment should comply strictly with published standards, as well as the manufacturer's recommendations. The following standards booklets (latest revision) are available from the sources indicated:

1. NFPA Standard 501C, "Standard for Recreational Vehicles", available from the National Fire Protection Association, Batterymarch Park, Quincy, MA 02269.
2. NFPA 70, "NFPA Handbook of the National Electric Code", obtained from same address as Item 1.
3. ANSI C1-1975 and ANSI 119.2-1975, available from the American National Standards Institute, 1430 Broadway, New York, NY 10018.
4. ANSI A119.2/NFPA 501C, available from the Recreational Vehicle Association, 1896 Preston White Drive, Reston, VA 22090.
5. California Administrative Code, Title 25, available from the State of California, Documents Section, P.O. Box 1015, North Highlands, CA 95660.
6. CSA Electrical Bulletin 946, available from the Canadian Standards Association, Housing and Constructions Materials Section, 178 Rexdale Boulevard, Rexdale, Ontario, Canada, M9W 1R3.

EQUIPMENT DESCRIPTION

Instructions and information in this section pertain to Generac air-cooled generators — more specifically, the installation of NP30 recreational vehicle generators. These generators are designed specifically for installing in recreational vehicles.

ENGINE GENERATOR OPERATING SPEED

The generators are driven by gasoline-powered, single-cylinder engines. The engines drive revolving fields (rotors), high frequency, permanent magnet alternators. The generators supply 120 volts AC at 60 Hertz. The generators revolving fields are driven at a variable speed depending on the instantaneous demand for power. Computers monitor that demand and adjust the engine speed to provide adequate power to the connected loads.

GENERATOR AC CONNECTION SYSTEM

The generators are equipped with single voltage AC connection systems. The following facts pertain to such a connection system:

- On the units, the 120 volts, connections system is protected by a circuit breaker.
- The AC connection system on all air-cooled generators use a GROUNDED neutral.
- A separate green ground wire is connected to the recreational vehicle's junction box.

LOCATION AND SUPPORT

GENERATOR LOCATION

The most desirable location for the generator set is between the vehicle's main frame members. However, this is seldom possible. Most units must be installed on the side of the vehicle and are difficult to reinforce.

Many recreational vehicles have been factory equipped with an area for the generator set. Some vehicles may even have a generator compartment, provided by the vehicle manufacturer.

Plan the generator location based on the following:

- The generator set must be installed on a framework that is part of the recreational vehicle, as outlined in the paragraph entitled "Generator Support."
- The location must provide an access opening that is large enough to permit generator removal (unless the generator is to be removed from underneath the supporting framework).
- The location must provide easy access to frequently serviced components, such as filters, oil drains, spark plugs and other common maintenance parts.
- The location must provide sufficient room to allow minimum clearance of at least 1 inch between all sides and 1-1/2 inches on top of the generator. If sound insulation is to be used on compartment walls and ceiling, the minimum recommended applies to the space between the generator and such insulation.
- The location must provide adequate cooling and ventilating air flow for the generator without a great deal of work and expense.

GENERATOR SUPPORT

The generator must be securely attached to a metal framework that has been made part of the vehicle frame structure by bolting or welding. The metal framework on which the generator will rest and which will restrain the generator set should consist of at least two horizontal beams. These beams should consist of (a) 1-1/2 inch square, 11 gauge steel tubing OR (b) 1-1/2 inch, 11 gauge angle iron. A typical supporting frame with horizontal support tubing, is shown in Figure 12.

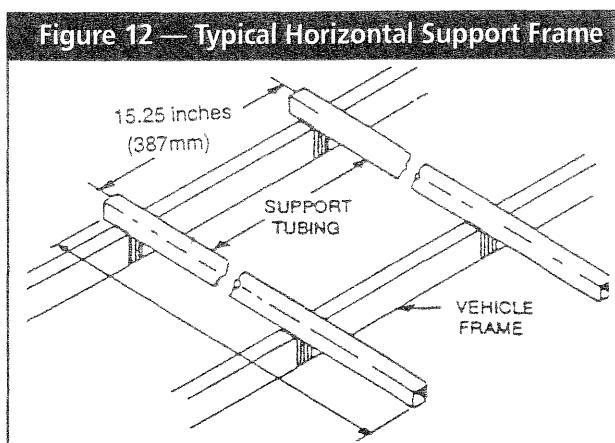

The generator can be installed so that it sits on top of the horizontal support tubing, if the vehicle design permits. Another method is to suspend the generator below the horizontal support tubing by means of suitable, structurally sound metal framework. The following general rules apply:

- Vehicle construction **MUST** be capable of supporting the weight of the generator.
- Whether the generator is mounted above the horizontal support tubing or suspended below the tubing, the supporting frame used must be structurally sound.
- If the generator cannot be bolted directly to the supporting frame or support tubing, consider using additional tubing, angle brackets or other supports to give the supporting frame sufficient strength.

SUSPENDED MOUNTING

If you are going to suspend the generator below the horizontal support tubing, the suspension method you use with the vehicle frame members must have the following: (a) be able to support the weight of the generator; and (b) provide sufficient restraint for the generator. One typical suspended mounting system is shown in Figure 13. The location of a suspended mounting system must be carefully planned, keeping the following general rules in mind:

- Protect the generator against road splash and debris. Baffles or splash guards may be required to protect certain areas of the generator. To make sure the generator is adequately protected, road test the installation through mud, water and slush.

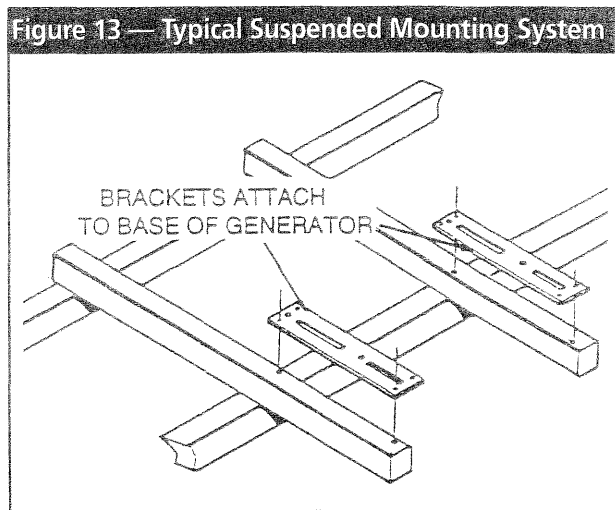

- The installer must make certain that selected location will permit adequate cooling and ventilating air flow to be supplied.

GENERATOR RESTRAINT

Use four 3/8"-16 hardened steel bolts (Grade 5) to fasten the generator to the supporting frame or the support tubing. These bolts must pass through (a) the generator mounting base, (b) the compartment floor, if a compartment is used, and (c) the supporting framework (Figure 14). All bolts must be long enough so that when tight, at least 3 threads are visible past the retaining lock nuts. Refer to "COMPARTMENT" section for location of generator mounting holes.

Figure 14 — Typical Generator Restraint

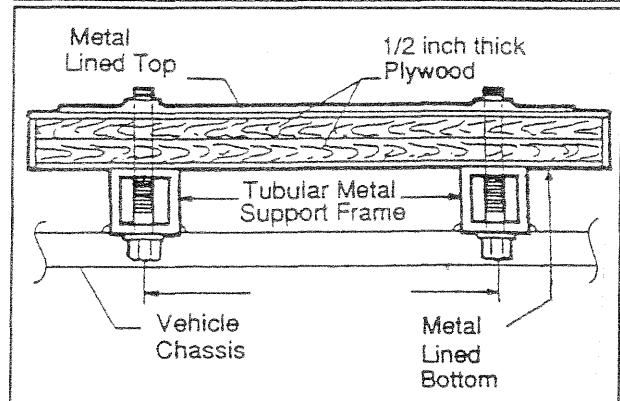

GENERATOR COMPARTMENTS

The generator set may or may not be installed inside a compartment that is constructed specifically for housing a generator. This section applies to generator compartments when they are installed. The following general rules apply to compartments:

- The generator compartment should be either constructed of, or lined with, 26 gauge galvanized steel.

IMPORTANT: ALUMINUM IS NOT AN ACCEPTABLE ALTERNATIVE TO GALVANIZED STEEL, DUE TO ALUMINUM'S LOW MELTING POINT.

- If the compartment is lined with galvanized steel, it may be constructed of any material. Generac recommends that the compartment be constructed of 1/2-inch thick plywood, with the floor made of a double thickness of plywood for added strength.
- All seams, splices and joints of the compartment walls (unless vapor tight by design) should be caulked.

IMPORTANT: CAULKING MUST BE DONE SO THAT THE CAULKING MATERIAL WILL STAY IN PLACE PERMANENTLY. PRESSING SUCH MATERIALS AS PUTTY TAPE ONTO JOINTS AND SEAMS WILL NOT MEET THAT REQUIREMENT. A HIGH QUALITY SILICONE RUBBER SEALANT IS RECOMMENDED.

- Holes and openings through the compartment walls for passage of electrical conduit, conductors, etc. into vehicle living area must be sealed vapor-tight with silicone rubber base sealant.
- If you use flexible metal conduit, seal the conduit at the end where it terminates inside the junction box. Flexible metal conduit is NOT vapor tight along its entire length.
- Seams and joints of the galvanized steel (whether used as a liner or the compartment itself) must be lapped and mechanically secured. Such seams may be manufactured, welded, bolted, riveted, or screwed. Manufactured lock seams are shown in Figure 15.

Figure 15 — Types of Lock Seams

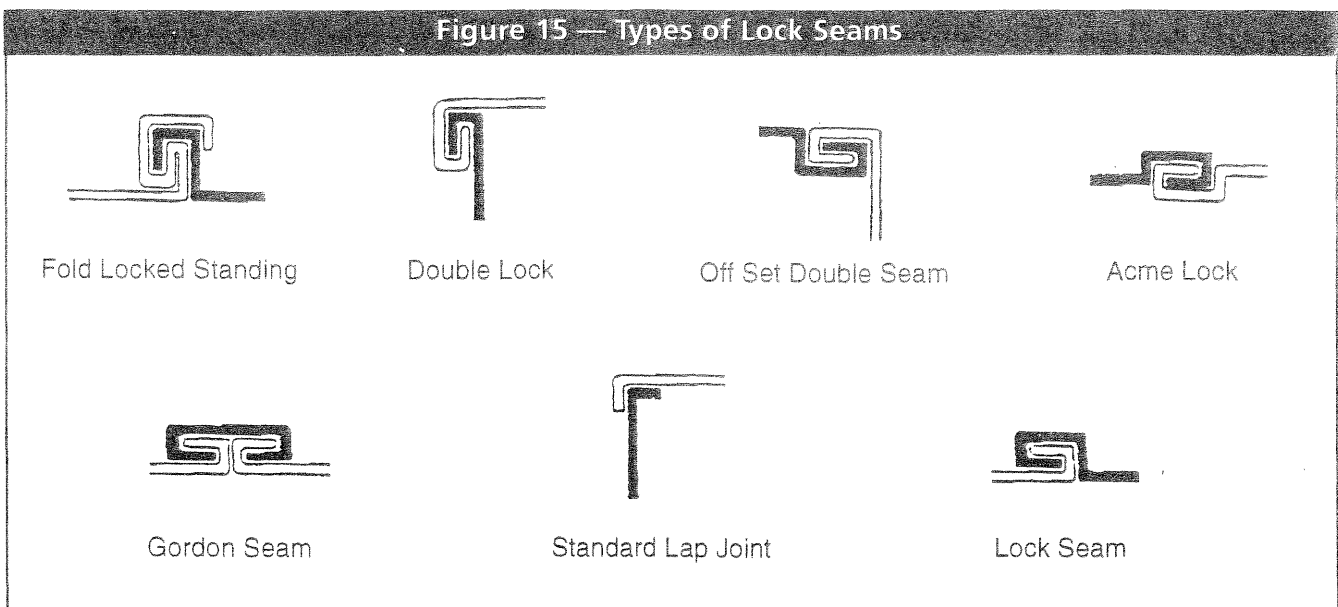

COMPARTMENT SIZE

Plan the compartment size carefully. Provide a minimum of at least 1 inch of clearance between the generator and compartment walls and 1-1/2 inch of clearance between the generator and the ceiling AFTER you have lined the compartment with metal, and AFTER you have installed sound insulation (Figure 16).

NOTE: Refer to the "Dimensions and Features" drawing in the back of this manual.

Figure 16 — Provide Clearance Around Generator

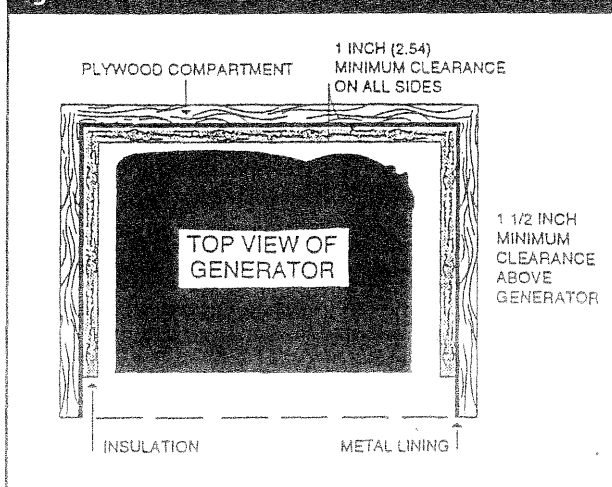

COMPARTMENT CONSTRUCTION

- The generator compartment should be constructed of 1/2 inch thick plywood. Make the compartment floor a double thickness of 1/2 inch plywood with the grain of the wood at cross section for added strength (Figure 17).

Figure 17 — Typical Compartment Construction

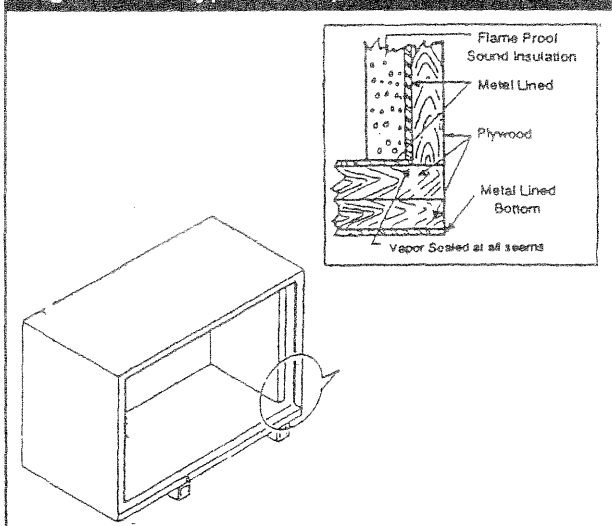

- Line the entire compartment interior with 26 gauge galvanized steel as described above.
- Line the exterior (underside) of the compartment floor with 26 gauge galvanized steel.

- Vapor seal all compartment seams and joints, to prevent poisonous, flammable or explosive vapors from entering the vehicle interior. Refer to the sealant information as noted below.

NOTE: Silicone rubber base sealant is an acceptable caulking material. Pressing putty tape onto compartment joints and seams is NOT acceptable.

- After the compartment has been metal lined and vapor sealed, line the compartment interior walls and ceiling with an approved, non-flammable sound insulating material. See "Sound Insulating Materials."



DANGER: DO NOT INSTALL SOUND INSULATION OR ANY ABSORBENT MATERIAL ON THE COMPARTMENT FLOOR INTERIOR. SUCH MATERIALS WILL BECOME SOAKED WITH COMBUSTIBLE OR EXPLOSIVE VAPORS AND LIQUIDS AND WILL BECOME A FIRE HAZARD.

- Openings in compartment walls for passage of electrical conduit, conductors, hoses, cables, etc., must be made vapor tight with suitable caulking material.
- Flexible conduit must be sealed internally at the end where it terminates inside a compartment's electrical junction box.

NOTE: The preceding is required because flexible conduit, due to its unique construction, is not vapor-tight along its entire length.



DANGER: DO NOT INSTALL ANY FLAMMABLE MATERIAL DIRECTLY ABOVE OR AROUND THE COMPARTMENT. HEAT, TRANSFERRED THROUGH THE COMPARTMENT STRUCTURE, MAY BE SUFFICIENT TO IGNITE, CHAR OR DISCOLOR SEAT CUSHIONS, FIBERBOARD AND OTHER FLAMMABLE MATERIALS. YOU MAY NEED TO USE APPROVED NON-FLAMMABLE INSULATING MATERIALS IN HIGH TEMPERATURE AREAS.

SOUND INSULATING MATERIALS

Once installers have determined that compartments are properly constructed and metal lined, they can add acoustical material. This may include additional sealant or insulating material, to reflect noise away from the vehicle interior.

Sound insulating materials should be of a non-flammable type. One excellent insulating material is a 1 inch thick fiberglass having a 2-pound density. When fiberglass is used, its coated side should face toward the compartment interior.

Using a combination of sound insulating materials can often reduce noise more effectively than a single material. For example, a sheet of lead or visco-elastic material, along with a layer of other acoustical material, is more effective than when a single material is used.

COMPARTMENT FLOOR CUTOUTS

You must provide openings in the generator compartment for the following items (Figure 18):

- Engine exhaust and cooling air outlets
- Generator cooling air inlet
- Four holes for passage of generator mounting bolts. See "Generator Restraint" on Page 16.



DANGER: FUEL LINES AND EXHAUST PIPING MUST NOT PENETRATE INTO VEHICLE LIVING AREA.

Figure 18 — Compartment Floor Cutout

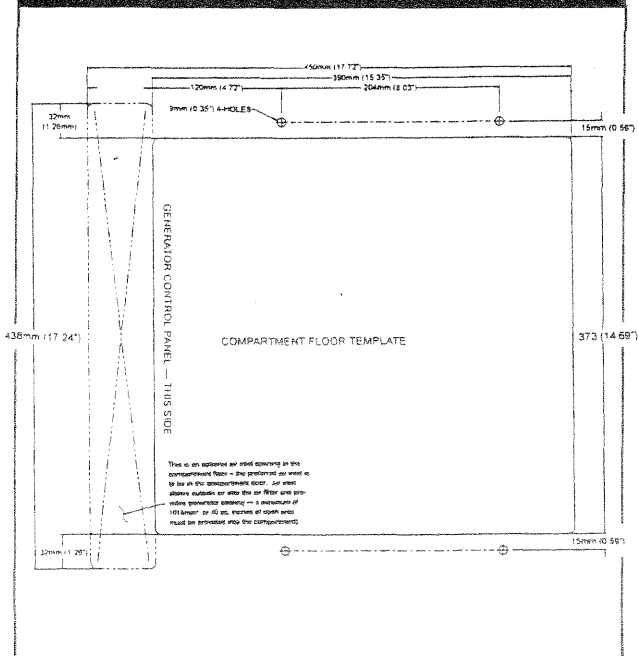

ACOUSTICS

If excessive noise levels should become a problem, the installer may wish to consider the following:

- Using special sound insulating materials.
- Construction of a special noise abatement compartment.

IMPORTANT: ANY METHOD USED TO REDUCE NOISE MUST NOT ADVERSELY AFFECT THE FLOW OF COOLING AND VENTILATING AIR INTO OR OUT OF THE COMPARTMENT.

In addition to the effective use of sound insulating materials, construction of a special noise abatement compartment might be considered to reduce noise levels. Such a compartment might be constructed as follows (Figure 19):

- Use 5/8-inch thick or 3/4-inch thick plywood in the compartment.
- Construct the compartment floor of a double thickness of 5/8-inch or 3/4-inch plywood.

- Line the compartment interior walls and floor, as well as the underside of the floor, with 26-gauge galvanized steel.
- Vapor seal all compartment seams and joints.
- Over the galvanized steel lining, install a selected combination of acoustical materials as mentioned in "Sound Insulating Materials."



DANGER: DO NOT INSTALL ANY INSULATION OR OTHER ABSORBENT MATERIALS ON THE INTERIOR OR UNDERSIDE OF THE COMPARTMENT FLOOR.

- Seal all compartment door edges to prevent noise leakage around the door perimeter.
- Line the compartment door interior (except for air openings) with suitable, fire proof sound insulation (such as 1-inch thick fiberglass with a 2-pound density).

Figure 19 — Typical Noise Abatement

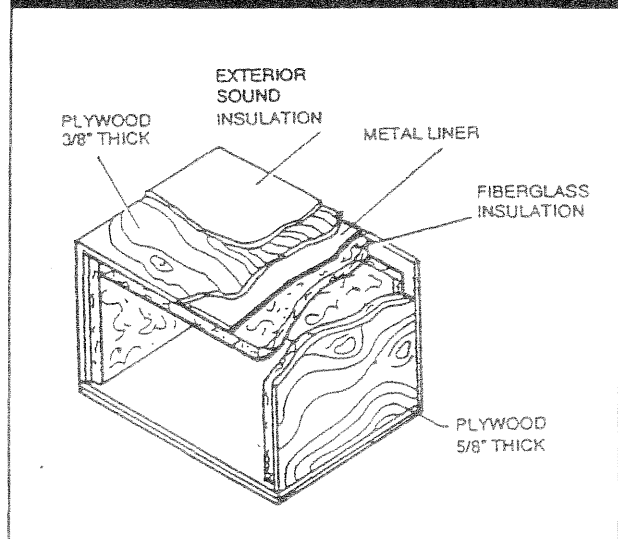

COOLING AND VENTILATING AIR

It is absolutely essential that an adequate flow of air for cooling, ventilating and engine combustion be supplied to the generator set. Without sufficient air flow, the engine-generator quickly overheats. Such overheating can cause serious operating difficulties and may also cause fire and personal injury. The installer must make sure that sufficient air is available to the generator for cooling, ventilating and combustion. The installer must also provide for a path for exhausting the cooling air to the exterior of a compartment, if so equipped.



DANGER: NEVER USE DISCHARGED COOLING AIR FOR HEATING OR PERMIT SUCH AIR TO ENTER THE VEHICLE INTERIOR. THIS AIR CONTAINS DEADLY CARBON MONOXIDE GAS AND OTHER POISONOUS, FLAMMABLE OR EXPLOSIVE GASES.

GENERATOR AIR FLOW

Engine operation drives cooling fans for the 2-stage cooling air system. A pressure fan draws cooling air into the top of generator and into the side of the control panel (Figure 20). This air flow cools the engine-generator and electronic components. The second part of cooling system, a suction fan, draws air that is heated from a hot engine into a collector pan at the base of the unit. This heated air (although cooler than exhaust muffler) is directed across the muffler to cool it. The heated air flow is then deflected out the bottom toward the ground.

Figure 20 — Air Flow Through Engine-Generator

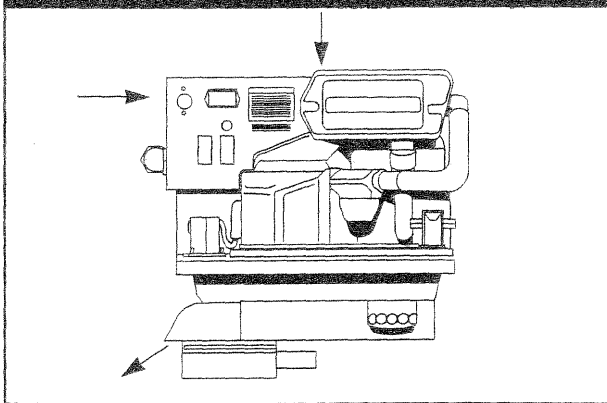

COOLING AIR INLET OPENINGS

Ideally, you should provide three air inlet openings, whether the generator is housed in a conventional compartment or not. Two of the openings should be 10 square inches and located as shown in Figure 21. The third opening should provide for a minimum of 40 square inches unrestricted and be located lower on the compartment door.

NOTE: Screening, louvers, or expanded metal that cover air openings restrict air flow that you must compensate for by making the actual air opening proportionately larger. See "Compensating for Restrictions."

Figure 21 — Air Inlet in Compartment Door

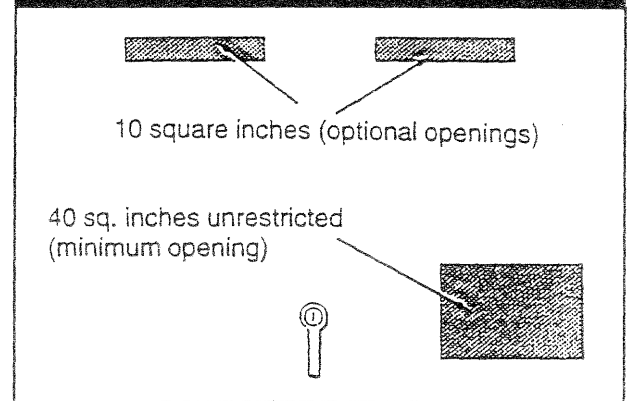

For conventional compartment mounted units, the air inlet is generally provided in the compartment door.

IMPORTANT: IF YOU PLAN TO INSTALL THE GENERATOR IN A COMPARTMENT, BE SURE TO LEAVE AT LEAST ONE AND A HALF (1-1/2") INCHES OF CLEARANCE BETWEEN THE GENERATOR AND COMPARTMENT WALLS AND CEILING. INCLUDE 26 GAUGE GALVANIZED STEEL LINING AND SOUND INSULATION WHEN YOU MEASURE FOR THIS 1-1/2 INCH CLEARANCE.

When the unit is installed on a suspended mounting system, one of several different methods of supplying air flow may be used as follows:

- Provide a door in the vehicle skirt having an air inlet opening (Figure 22).

Figure 22 — Suspended Mount: Inlet Door

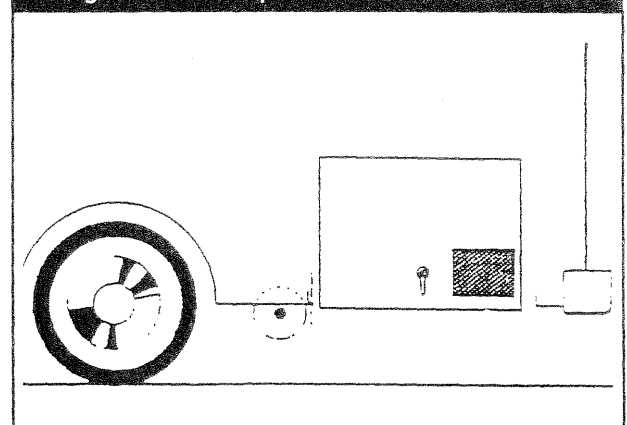

- Using ductwork (Figure 23). The installer must be sure air is available to the top of the generator since air inlets are located at the top.

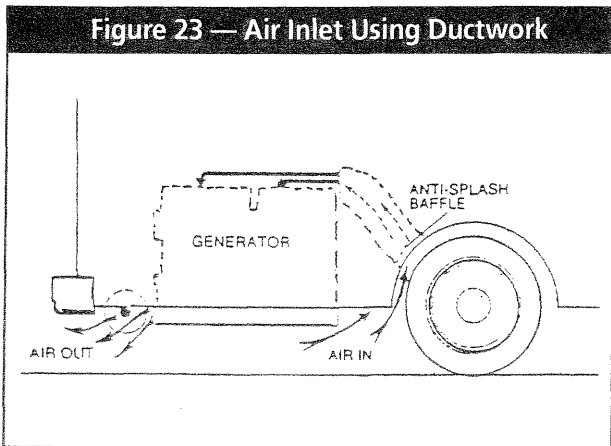

- By providing an opening in the vehicle skirt and space above the generator for cooling air flow (Figure 24). Recommended clearance above the top of the generator is at least 2 inches.

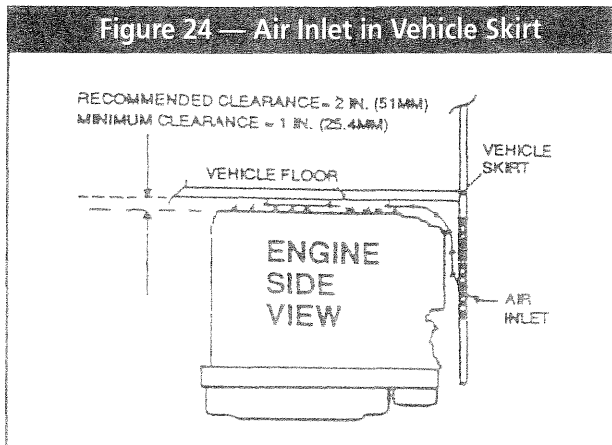

COMPENSATING FOR RESTRICTIONS

Such materials as screening, louvers, or expanded metal can restrict the free flow of air. Compensate for this restriction by making the actual air opening proportionately larger.

Some materials may offer only a 60 percent "free air inlet area." Other more efficient materials may provide up to a 90 percent free air inlet area. The percentage of free air inlet opening is usually available from the material supplier or manufacturer.

TO DETERMINE THE ACTUAL AIR INLET OPENING SIZE REQUIRED, DIVIDE 40 SQUARE INCHES BY THE PERCENTAGE OF FREE AIR INLET AREA FOR THE MATERIAL YOU WILL USE.

For example: If you plan to use screening with an 80% free air inlet area, divide 40 by 0.8, which results in 50 square inches. Minimum actual size of air inlet opening in this case is 50 square inches. An opening that measures 4 inches wide by 12-1/2 inches long provides the required air flow (4 x 12.5 = 50 square inches).

TESTING THE INSTALLATION

Generac recommends testing the installation to be sure adequate cooling air flow is available to the unit before placing the unit into service. If the unit shows signs of overheating, you will need to enlarge the air openings. Never place a unit into service until absolutely certain that cooling and ventilation is adequate.

IMPORTANT: YOU MUST TEST THE INSTALLATION ESPECIALLY IF YOU BRING IN AIR FROM BELOW THE GENERATOR SET.

GASOLINE FUEL SYSTEM

Installing a gasoline fuel system (Figure 25) for recreational vehicle generator sets must comply with applicable codes, standards and regulations. The entire fuel system must be completely free of leaks. There must be no possibility of gasoline vapors entering the vehicle interior.

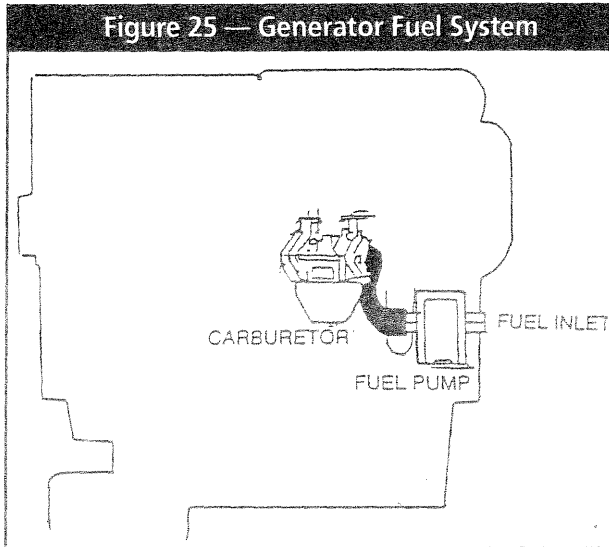

DANGER: GASOLINE IS HIGHLY FLAMMABLE AND ITS VAPORS ARE EXPLOSIVE. COMPLY WITH ALL CODES, STANDARDS AND REGULATIONS PERTAINING TO GASOLINE FUEL SYSTEMS USED IN INDUSTRIAL MOBILE GENERATORS. PROPERLY INSTALL AND MAINTAIN THE FUEL SYSTEM AND KEEP IT ENTIRELY FREE OF LEAKS. GASOLINE VAPORS MUST NOT ENTER THE VEHICLE INTERIOR.

Factory installed generator fuel system components include (a) fuel filter, (b) 12-volts DC electric pump, (c) engine carburetor, and (d) interconnecting lines and fittings. Connect a fuel supply line to the fuel filter inlet. Use a flexible length of approved fuel hose between the fuel filter inlet connection and rigid fuel lines.

FUEL TANK

Either the generator must share the vehicle engine's fuel tank, or you must install a separate fuel tank for the generator set. All fuel tanks installed on the vehicle must be constructed, installed, restrained so it complies with applicable codes, standards and regulations.

If the generator is to share the vehicle engine's tank, separate fuel pickup tubes are required for the engine and the generator. Generac recommends that you make the fuel pickup tube about 2 to 3 inches shorter than the vehicle engine's pickup tube. This prevents the generator from depleting the entire fuel supply during prolonged generator operating periods.



CAUTION: Do NOT tee the generator fuel supply line into the vehicle engine fuel supply line. If this is done, the generator will be starved of fuel when both engines are operating at the same time. Also, while the vehicle engine is not running, generator operation may drain the vehicle engine supply line, making it difficult to start the vehicle engine.

GENERATOR FUEL SUPPLY LINE

■ RIGID FUEL LINES

Those lines used to supply fuel from a tank to the generator must comply with applicable codes, standards and regulations. The following generator rules apply to rigid fuel lines:

- Rigid lines should be of annealed, seamless, drawn aluminum or steel.
- Lines and fittings must comply with SAE J512F, "Standard Automotive Fittings", or with ANSI B126.26 (latest edition).
- Route the fuel line so that at least 2 inches of clearance is maintained between the line and any exhaust system parts.
- Do not attach electrical wiring to fuel lines. Route the wiring so it cannot come into contact with any fuel line.
- Route fuel lines so if they leak, fuel does not drip onto any electrical or exhaust system parts.
- Use non-ferrous metal straps without sharp edges to secure fuel lines.

■ FLEXIBLE FUEL LINE

Use an approved flexible length of fuel hose between the generator fuel inlet connection and rigid fuel lines. This prevents breaking of the line caused by vibration, shifting, settling or movement. The following rules apply:

- The flexible hose must comply with SAE J30B, "Standard for Fuel and Oil Hose". It must be approved for use with gasoline.
- The hose should be at least 6 inches longer than is needed to prevent the hose from rupturing if the generator shifts or settles.

EXHAUST SYSTEM

The generator exhaust system must be safely and properly installed. Only approved mufflers and other exhaust system parts must be used. A properly installed exhaust system must be vapor tight, quiet and completely safe.



CAUTION: Never tee the generator engine exhaust pipe into the vehicle engine exhaust piping. This causes excessive back pressure on the generator engine. Also, water from one engine can damage the other engine.



DANGER: THE GENERATOR ENGINE GIVES OFF DEADLY CARBON MONOXIDE GAS THROUGH ITS EXHAUST SYSTEM. THIS DANGEROUS GAS, IF BREATHED IN SUFFICIENT CONCENTRATIONS, CAN CAUSE UNCONSCIOUSNESS OR EVEN DEATH. SYMPTOMS OF CARBON MONOXIDE POISONING ARE (a) INABILITY TO THINK COHERENTLY, (b) VOMITING, (c) TWITCHING MUSCLES, (d) THROBBING IN TEMPLES, (e) DIZZINESS, (f) HEADACHE, (g) WEAKNESS AND SLEEPINESS. IF ANY OF THESE SYMPTOMS ARE EXPERIENCED, MOVE INTO FRESH AIR IMMEDIATELY. IF SYMPTOMS PERSIST, GET MEDICAL ATTENTION. DO NOT OPERATE THE GENERATOR UNTIL ITS EXHAUST SYSTEM HAS BEEN INSPECTED AND REPAIRED.

MUFFLERS AND SPARK ARRESTORS

Exhaust mufflers and spark arrestors that Generac supplies meet code and standard requirements, and are approved by the U.S. Forest Service. Use only mufflers and parts approved by Generac. Any person(s) installing an unapproved muffler, or an unapproved exhaust system part, or modifying an exhaust system in any way that might cause a hazard, is liable for any damage, injury or warranty expense that might be caused by such unapproved installation or modification.

Failure to provide and maintain a spark arrestor may be in violation of the law. If this generator is used on any forest covered, brush covered, or grass covered unimproved land, you must provide a spark arrestor. The vehicle owner or operator must maintain this device in good condition. In the State of California, the preceding is required by law (Section 4442 of the California Public Resources Code). Other states may have similar laws. Federal laws apply on federal lands.

TYPE OF EXHAUST SYSTEM

The NP-30G generator has a configuration for a bottom out exhaust system and is equipped with such an exhaust muffler (Figure 26).

EXHAUST SYSTEM SAFETY

- Maintain a clearance of at least 3 inches (76mm) between exhaust system parts and any combustible material (such as wood, felt, cotton, organic fibers or other like material). If you cannot maintain the 3-inch clearance, locate, insulate or shield the exhaust part(s) so that the temperature of any combustible material is not raised more than 117°F (65°C) above the ambient air temperature.
- Extend the exhaust system at least one inch (25mm) past the outer edge of the vehicle.
- Terminate the exhaust tailpipe such that exhaust gases will not be drawn back into the generator compartment and recirculated.
- If there is any possibility of the tailpipe or muffler being damaged, protect these damage prone areas by means of a protective device (such as a "skid bar").
- Install the generator exhaust system according to safe automotive practices.
- Use enough exhaust system hangers to prevent any part of the system from being dislocated.
- Use exhaust system parts recommended by Generac. Using unapproved exhaust mufflers and exhaust system parts is the responsibility of the person(s) installing such unauthorized parts.
- Do not terminate the exhaust system under the vehicle.
- Do not terminate the exhaust system under any opening, window or vent which can be opened or is not permanently sealed from the vehicle interior.
- Exhaust piping must be large enough to prevent excessive back pressure on the generator engine.
- Never tee the generator engine exhaust pipe into the vehicle engine exhaust piping. This causes excessive back pressure on the generator engine. Also, water from one engine can damage the other engine.
- Plan exhaust system installation carefully. Comply with all applicable codes, standards and regulations.

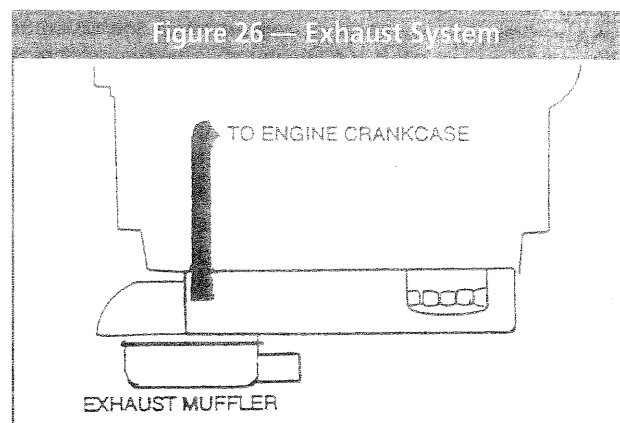

ELECTRICAL CONNECTIONS

Be sure to read "Generator AC Connection System" on Page 4.

The following general rules apply to electrical connections in a recreational vehicle:

- Qualified electricians who are familiar with applicable codes, standards and regulations should install electrical wiring.
 - The wiring should comply with codes, standards and regulations. The National Electric Code (NFPA 70), as well as state and local codes, apply.
 - Switches and circuit breakers should be of a type approved for use in recreational vehicles and must be mounted and installed to prevent damage from road shock.
 - Wiring must be of adequate size, with approved insulative qualities, and properly supported.
- Conduit and wire openings into generator compartment (if used) must be vapor-sealed, to prevent entry of flammable, explosive or poisonous gases into the vehicle.

ELECTRICAL JUNCTION BOX

Install an approved, square electrical junction box that has a blank cover on the interior or exterior wall of the area you plan to install the generator (NOT on the generator). Route the generator's AC output leads into this junction box through approved flexible conduit, and into this junction box. This is the point of first termination for generator AC output leads.

WIRING

- Wiring should be of stranded copper to reduce chance that vibration may cause breakage.
- Wire gauge size of wires should be large enough to handle at least 115% of the installed generator's rated maximum current.
- If neutral conductors are used, they must be the same size as other leg wires.
- Route power supply conductors from generator AC output leads T1 (black) and T2 (white) and the green ground wire through approved flexible conduit to the electrical junction box on the compartment wall.

If flexible metal conduit is used between the generator and the compartment junction box, the conduit end that terminates the compartment junction box, must be vapor-sealed. Flexible metal conduit is NOT vapor tight along its entire length.

- From the junction box route power supply wires through approved conduit to either (a) double-pole, double-throw transfer switch, or (b) approved isolation receptacle. Connecting to a transfer switch or isolation receptacle must prevent vehicle electrical circuits from being connected to two different power supplies at the same time (such as generator and dockside power).

- Conductors must be rated 221°F (105°C) or must be of a larger conductor size.

GENERATOR AC CONNECTIONS

Generator AC output leads T1 (black) and T2 (white) come out of the generator as shown in Figure 27. Lead T1 (black) is "hot." Lead T2 (white) is the "neutral" lead and is internally connected to ground. The green lead (0) connects to ground in the junction box of the recreational vehicle.

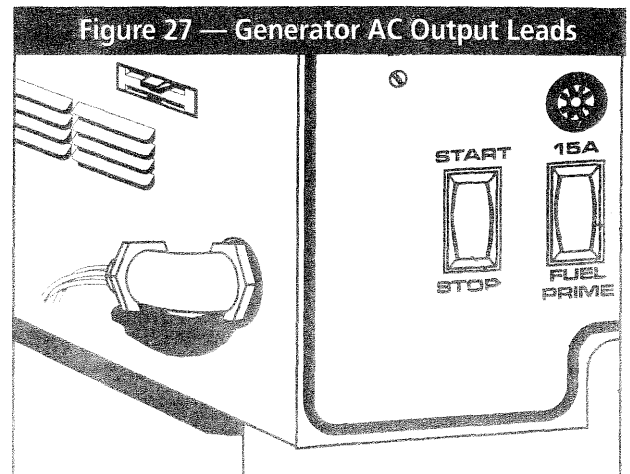

Line T1 (black) is protected against overload by the circuit breaker (CB1). Use line T1-T2 to operate 120 volts, 1-phase, 60 Hz, AC loads.



CAUTION: Do NOT connect electrical loads in excess of any circuit breaker rating or you will develop problems with circuit breaker tripping, which causes a loss of AC output. Also, do NOT exceed the generator's rated wattage capacity. Add the watts or amperes of all lighting, appliance, tool and motor loads the generator will operate at one time. This total should be less than the unit's rated wattage/ampere capacity.

CONDUIT

Route the conductors between the generator and the junction box through approved, flexible conduit. The following general rules apply:

- Cut wiring to the required length and allow extra wire for junction box connections.
- Carefully prepare conduit ends, to prevent sharp edges from cutting through wiring insulation.
- Route conduit so it does not interfere with generator movement.
- If you use metallic conduit, vapor seal the end of the conduit where it enters the junction box. Do this because flexible metallic conduit is not vapor proof along its entire length.

ISOLATING DIFFERENT POWER SOURCES

Conductors from the junction box must terminate in a double pole, double throw transfer switch (Figure 28). An alternate method for isolating different power sources is by using an isolating receptacle (Figure 29 on Page 25). Whichever method you use, you must be certain that both power sources are NOT connected at the same time.

GROUND FAULT CIRCUIT INTERRUPTERS

The National Electric Code (NFPA 70, 551-7) requires that you install ground fault circuit interrupters (GFCIs) on all external and some internal electrical receptacles. Contact your manufacturer or dealer for recommendations.

POWER SUPPLY CORD

The power supply cord must comply with all applicable codes, standards and regulations. It must be large enough to handle the full amperage to which it will be subjected.

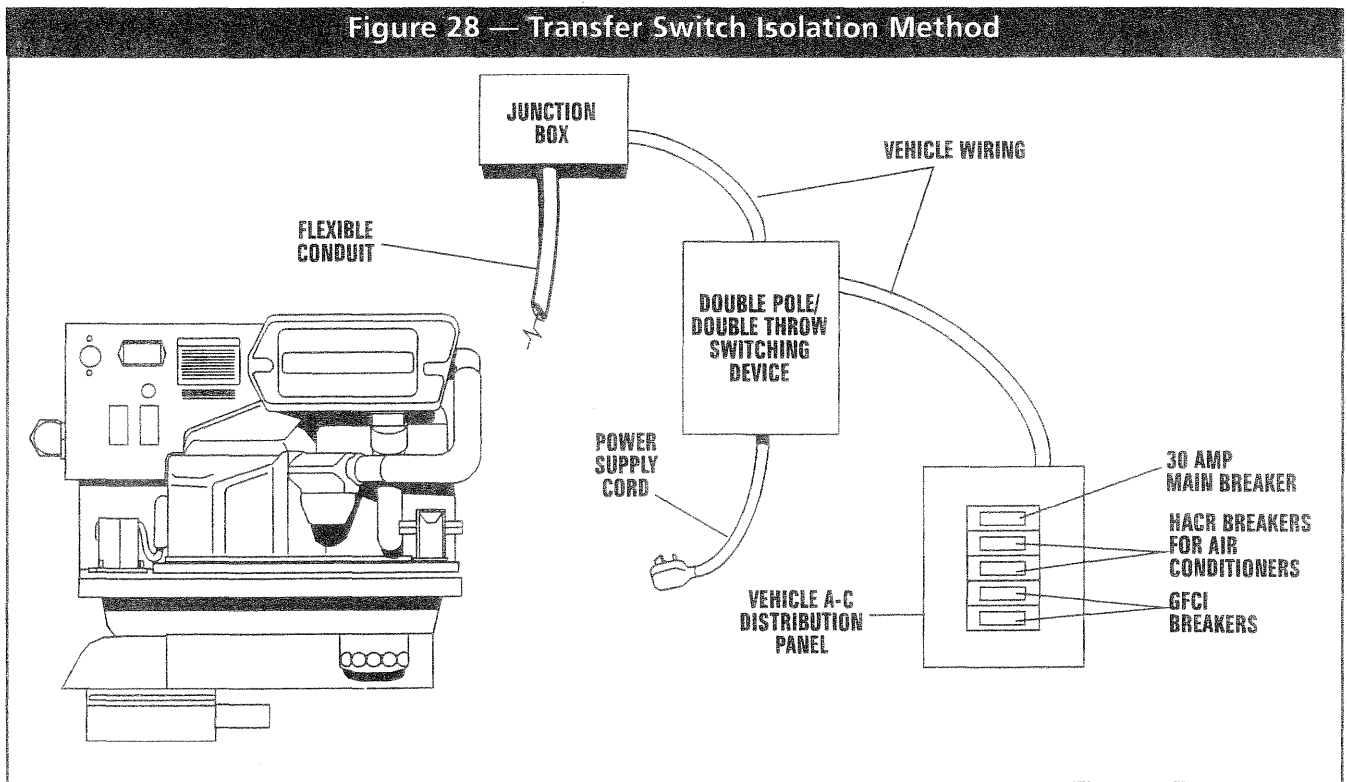
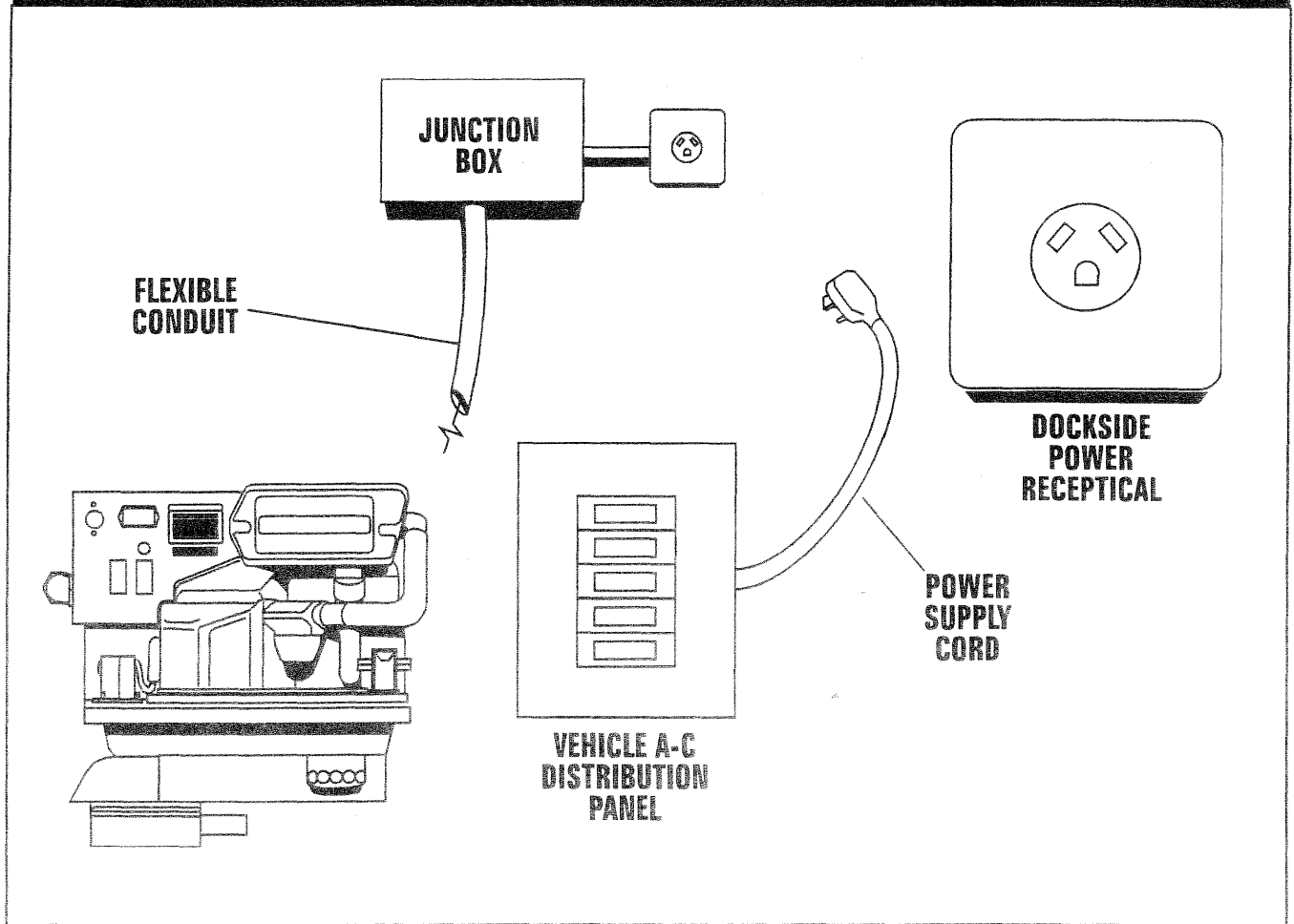

Figure 29 — Installation with Isolation Receptacle



BATTERY INSTALLATION

RECOMMENDED BATTERY

Install a battery that meets the following requirements:

- Battery must be a 12 volt, automotive type storage battery.
- For prevailing ambient temperatures above 32°F (0°C), use a battery rated 70 amp-hours and capable of delivering 360 cold cranking amperes.
- For prevailing ambient temperatures below 32°F (0°C), use a battery rated 95 amp-hours and capable of delivering 450 cold cranking amperes.

IMPORTANT: IF THE BATTERY IS TO BE USED TO POWER OTHER VEHICLE ACCESSORIES, AS WELL AS START THE GENERATOR, YOU MAY NEED A BATTERY WITH A LARGER CAPACITY.

BATTERY CABLES

Using battery cables that are too long or too small in diameter may cause a drop in voltage which causes starting problems. For best cold weather starting, the voltage drop between battery terminals and the generator connection point should not exceed 0.12 volts per 100 amperes of cranking current.

Select battery cables based on (a) cable length, and (b) prevailing ambient temperatures. Generally, the longer the cable and the colder the weather, the larger the cable size must be as shown in the chart below.

CABLE LENGTH in Feet (meters)	CABLE SIZE
0 to 10 (0 to 3)	2*
11 to 15 (3.4 to 4.5)	0
16 to 20 (4.5 to 6)	000

*For warm weather, use No. 2 cable up to 20 feet.

BATTERY CABLE CONNECTIONS

1. Connect the battery cable from the battery post or terminal indicated by a POSITIVE, POS or (+) to the large lug on the starter contactor as indicated in Figure 31.
2. Connect the battery cable from the battery post indicated by a NEGATIVE, NEG or (-) to the frame ground connection (Figure 30).

NOTE: If the generator compartment is grounded to the vehicle chassis, you need not connect a NEGATIVE battery cable to the frame ground on the generator base. Connect the negative cable to the frame ground of the chassis.

3. Connect cables so the connectors are clean and tight.

BATTERY COMPARTMENT

Install the generator battery in its own, vented compartment. Place the battery compartment away from any source of heat, sparks or flame.

Provide ventilation openings in the battery compartment. The minimum size of openings should be 2 square inches at the top of the compartment. Mount the battery on a strong, rigid supporting structure, where leaks and spills of battery fluid will not cause damage.

Figure 30 — Connecting Battery Cables

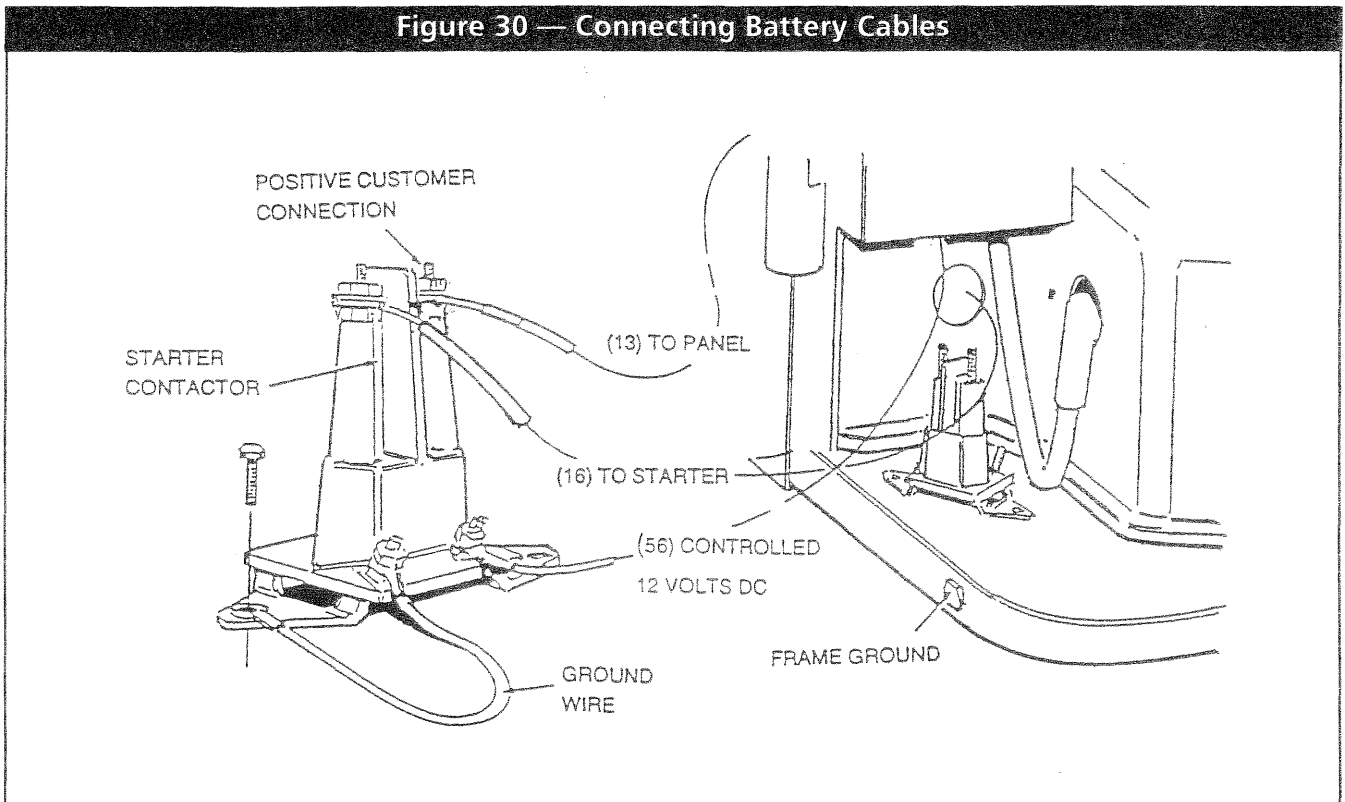

OPTIONAL ACCESSORIES

A plug-in receptacle (Figure 31) is provided on the generator set, near the AC connection wires. Use this receptacle to connect an optional remote-mounted start/stop panel to the generator. Installation of such a panel will permit you to start and stop the generator engine from any convenient location inside the vehicle.

Figure 31 — Remote Panel Plug-in Receptacle

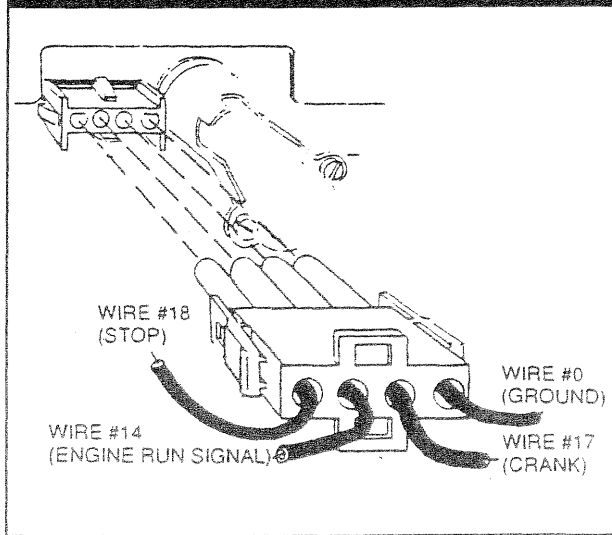

REMOTE PANEL MODELS

■ MODEL 9042

This remote panel (Figure 32) mounts a rocker type start/stop switch and a "Generator Run" advisory lamp. The lamp will turn on to indicate the engine is running.

Figure 32 — Model 9042 Remote Panel

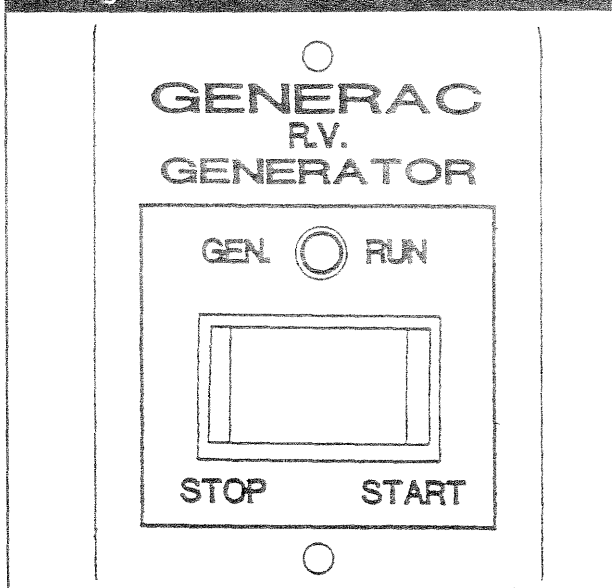

■ MODEL 9043

This panel mounts a rocker type switch, a "Generator Run" lamp and an hourmeter (Figure 33). Use the hourmeter in conjunction with the periodic maintenance schedule for your generator.

Figure 33 — Model 9043 Remote Panel

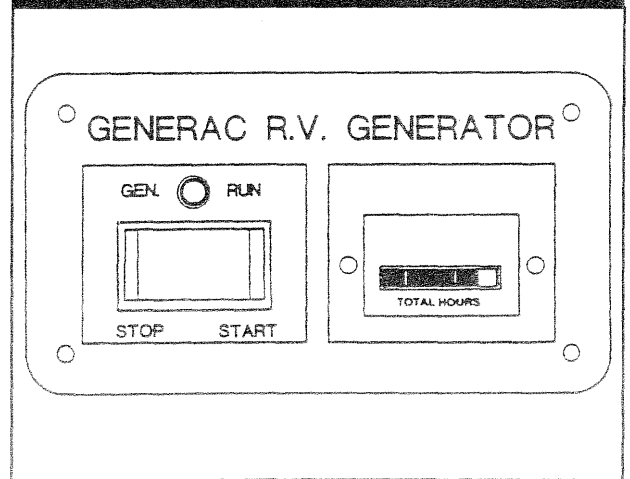

REMOTE PANEL CABLES

Interconnection cables are available from Generac for connecting the optional remote panels to the generator receptacle.

- To order a 10-foot long, 4-wire cable, specify Model 9045.
- To order a 30-foot long, 4-wire cable, specify Model 9046.

POST INSTALLATION TESTS

The air cooled generator set was factory tested and adjusted using gasoline as fuel. You should not be required to adjust the unit any further except under special circumstances.



WARNING: DO NOT MAKE ANY UNNECESSARY ADJUSTMENTS. FACTORY SETTINGS ARE CORRECT FOR MOST APPLICATIONS. WHEN MAKING ADJUSTMENTS, HOWEVER, BE CAREFUL TO AVOID OVERSPEEDING THE ENGINE.

BEFORE INITIAL START UP

Before starting, complete the following:

1. Check engine crankcase oil level and, if necessary, fill to dipstick FULL mark with the recommended oil. Do not fill above FULL mark.
2. Check the fuel supply. Gaseous fuel lines must have been properly purged and leak tested in accordance with applicable fuel-gas codes. All fuel shutoff valves in the fuel supply lines must be open.



DANGER: IF AN LP (PROPANE) GAS FUEL SYSTEM HAS BEEN INSTALLED, IT MUST HAVE BEEN PROPERLY TESTED FOR LEAKS BEFORE OPERATING THE SYSTEM IN COMPLIANCE WITH ANSI A119.2/NFPA 501C. NO LEAKAGE IS PERMITTED. YOU MUST BE SURE NO GASEOUS FUEL VAPORS ENTER THE VEHICLE INTERIOR.

INITIAL START

When absolutely certain that the unit has been properly installed and prepared for use, start the engine as follows:

1. Turn off all electrical loads. Do this by setting the generator main circuit breaker to its "OFF" or "OPEN" position.
2. Refer to the Owner's Manual shipped with unit for cranking and starting instructions. The engine may require more cranking for initial starting since the fuel lines have to be primed.
3. Let the engine warm up for about five minutes to allow internal temperatures to stabilize.
4. Carefully inspect the engine-generator for fuel, oil and exhaust system leaks. Before proceeding to the next step, correct any leakage immediately.
5. When all tests and adjustments at no-load are completed, apply electrical loads and check for proper operation under load. See "Testing Under Load". Run the unit at least 30 minutes with loads applied.

6. Turn off all electrical loads by setting the generator main circuit breaker to "OFF" or "OPEN."

7. Let the unit run at no-load for a few minutes to stabilize internal engine-generator temperatures. Then, shut down the engine.

IMPORTANT: THE GENERATOR SET WAS THOROUGHLY TESTED AND ADJUSTED AT THE FACTORY BEFORE SHIPPING. NO ADDITIONAL ADJUSTMENT SHOULD BE NECESSARY. ONLY QUALIFIED SERVICE TECHNICIANS WHO HAVE BEEN TRAINED SHOULD PERFORM ADJUSTMENTS OUTLINED IN THIS MANUAL.

TESTING UNDER LOAD

Apply electrical loads equal to about 75-100% of the unit's rated wattage/ampere capacity.

Let the unit run at least 30 minutes with load applied. During this part of the test, check that the unit is not running excessively hot and that adequate cooling air flow is available. You must not allow the unit to overheat during prolonged operation.

NOTE: The generator engine is equipped with a high oil temperature switch. The switch has normally-open (N.O.) contacts. When the oil temperature is too high, switch contacts close, and engine shuts down automatically.

IMPORTANT: GENERAC RECOMMENDS THAT YOU TEST THE GENERATOR FOR ADEQUATE COOLING.

INSTALLATION CHECK LIST

LOCATION AND SUPPORT

- ___ 1. The NP generator is properly located.
- ___ 2. The generator is properly supported.
- ___ 3. The generator is properly restrained.

COMPARTMENT

- ___ 1. Compartment construction is proper.
- ___ 2. Holes/openings are vapor-sealed.
- ___ 3. Compartment size is correct.
- ___ 4. Compartment is vapor-sealed.
- ___ 5. Sound insulation is O.K.
- ___ 6. Floor cutouts properly completed.

COOLING and VENTILATING AIR

- ___ 1. Air flow is adequate.
- ___ 2. Air inlet opening is correct.
- ___ 3. Compensate for restrictions
- ___ 4. Installation has been tested

GASOLINE FUEL SYSTEM

- ___ 1. Fuel tank complies with code.
- ___ 2. Fuel system properly installed.

EXHAUST SYSTEM

- ___ 1. Complies with code requirements.
- ___ 2. Properly and safely installed.

ELECTRICAL CONNECTIONS

- ___ 1. Comply with code requirements.
- ___ 2. Junction box properly installed.
- ___ 3. Wiring meets all standards.
- ___ 4. All connections are correct.
- ___ 5. Conduit properly installed and sealed.
- ___ 6. Generator properly bonded to vehicle.

BATTERY INSTALLATION

- ___ 1. Recommended battery is installed.
- ___ 2. Recommended cables are installed.
- ___ 3. Cables are clean and tight.
- ___ 4. Cables are properly connected.
- ___ 5. Proper ventilation is provided.

POST INSTALLATION TESTS

- ___ 1. All tests properly completed.

OPTIONS AND ACCESSORIES

Check that remote start/stop panels (if used) are properly installed.

If an hourmeter kit is installed, check that job was done properly.

If any other options and accessories are installed, check that they were installed properly.

DATE OF INSTALLATION

NAME OF INSTALLER

SIGNATURE OF INSTALLER

MAJOR FEATURES AND DIMENSIONS

THIS IS AN OPTIONAL AIR INLET OPENING IN THE COMPARTMENT FLOOR. THE PREFERRED AIR INLET IS TO BE IN THE COMPARTMENT DOOR. (THE AIR INLET ALLOWS OUTSIDE AIR INTO THE AIR FILTER AND PROVIDES GENERATOR COOLING-A MINIMUM OF 106MM OR 40 SQ. INCHES OF OPENING MUST BE PROVIDED IN THE COMPARTMENT.)

#M8 MOUNTING FASTENERS
(TOTAL OF 4 REQUIRED)

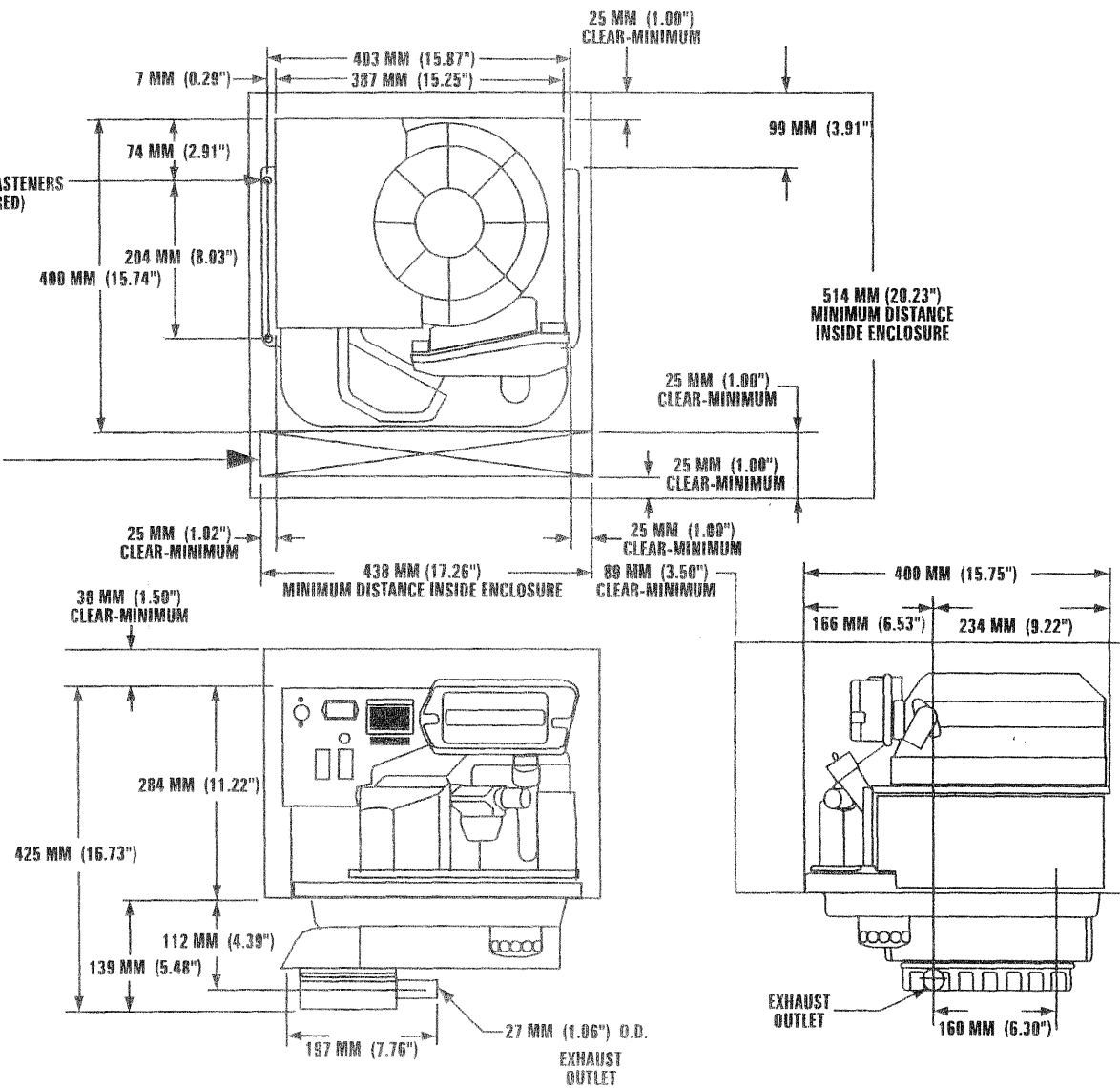

TROUBLESHOOTING

PROBLEM	POSSIBLE CAUSES	REMEDY
Engine won't crank.	<ol style="list-style-type: none"> 1. 15 amp fuse is blown 2. Loose corroded or defective battery cables. 3. Defective engine Start/Stop switch. 4. Defective starter contactor. 5. Defective starter motor. 	<ol style="list-style-type: none"> 1. Replace 15 amp fuse 2. Tighten, clean or replace as necessary. 3. Replace Start/Stop switch. 4. Replace contactor. 5. Replace starter motor.
Engine cranks but won't start.	<ol style="list-style-type: none"> 1. Out of fuel. 2. Fuel pump is defective. 3. Open Wire #14 from Eng. Control Bd. 4. Engine is flooded. 5. Spark plug defective. 	<ol style="list-style-type: none"> 1. Replenish fuel. 2. Replace fuel pump. 3. Reconnect wire. 4. Wait 5-10 min. before trying. 5. Clean, regap or replace plug.
Engine starts hard, runs rough.	<ol style="list-style-type: none"> 1. Air cleaner plugged or damaged 2. Defective spark plugs. 	<ol style="list-style-type: none"> 1. Clean or replace as needed. 2. Clean, regap or replace plugs.
Engine starts, shuts down when Start/Stop switch is released.	<ol style="list-style-type: none"> 1. Engine oil is low. 2. Engine is overheated. 3. Defective Low Oil Pressure System 4. Defective Engine Control Board 5. Defective Computer Control Board 	<ol style="list-style-type: none"> 1. Check oil; add as needed. 2. Check for adequate ventilation. 3. Have serviced/replaced. 4. Have board serviced/replaced. 5. Have board serviced/replaced.
Start/Stop switch at Stop, engine continues to run.	<ol style="list-style-type: none"> 1. Defective Start/Stop switch 2. Open/disconnected wire #18 between Start/Stop switch and Engine Control 3. Open/disconnected wire #0 between Start/Stop switch & Engine Control Bd. 4. Defective Engine Control Board 	<ol style="list-style-type: none"> 1. Replace switch. 2. Reconnect or close wire. 3. Reconnect or close wire. 4. Replace board.
No AC output from generator.	<ol style="list-style-type: none"> 1. Check circuit breaker. 2. Check vehicle circuit breaker & fuses. 3. Transfer sw. set to NORMAL position. 4. Generator internal failure 	<ol style="list-style-type: none"> 1. Reset to ON or CLOSED. 2. Reset and replace if necessary. 3. Set to GENERATOR position. 4. Take generator to an Authorized Generac facility.

ELECTRICAL DATA

Drawing No. 88928

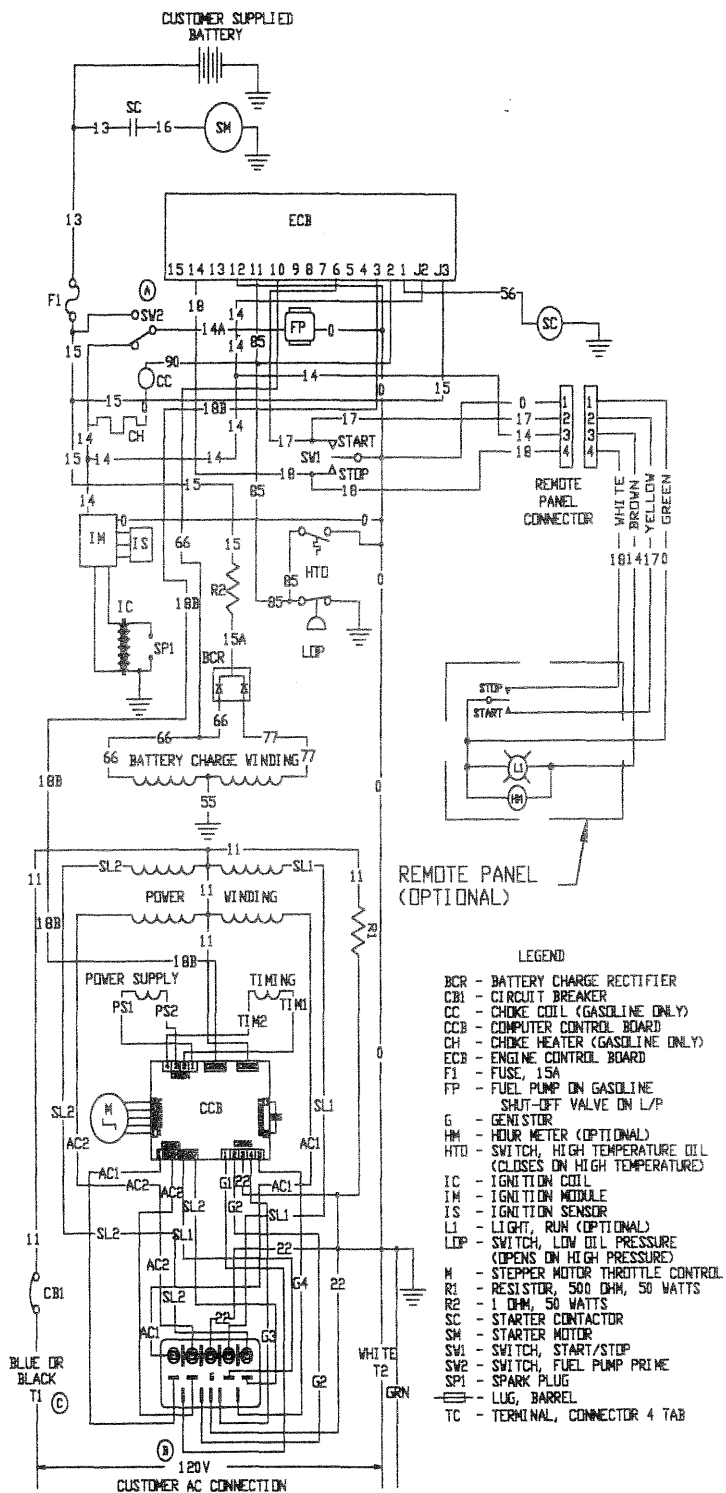

ELECTRICAL DATA

Drawing No. 88928

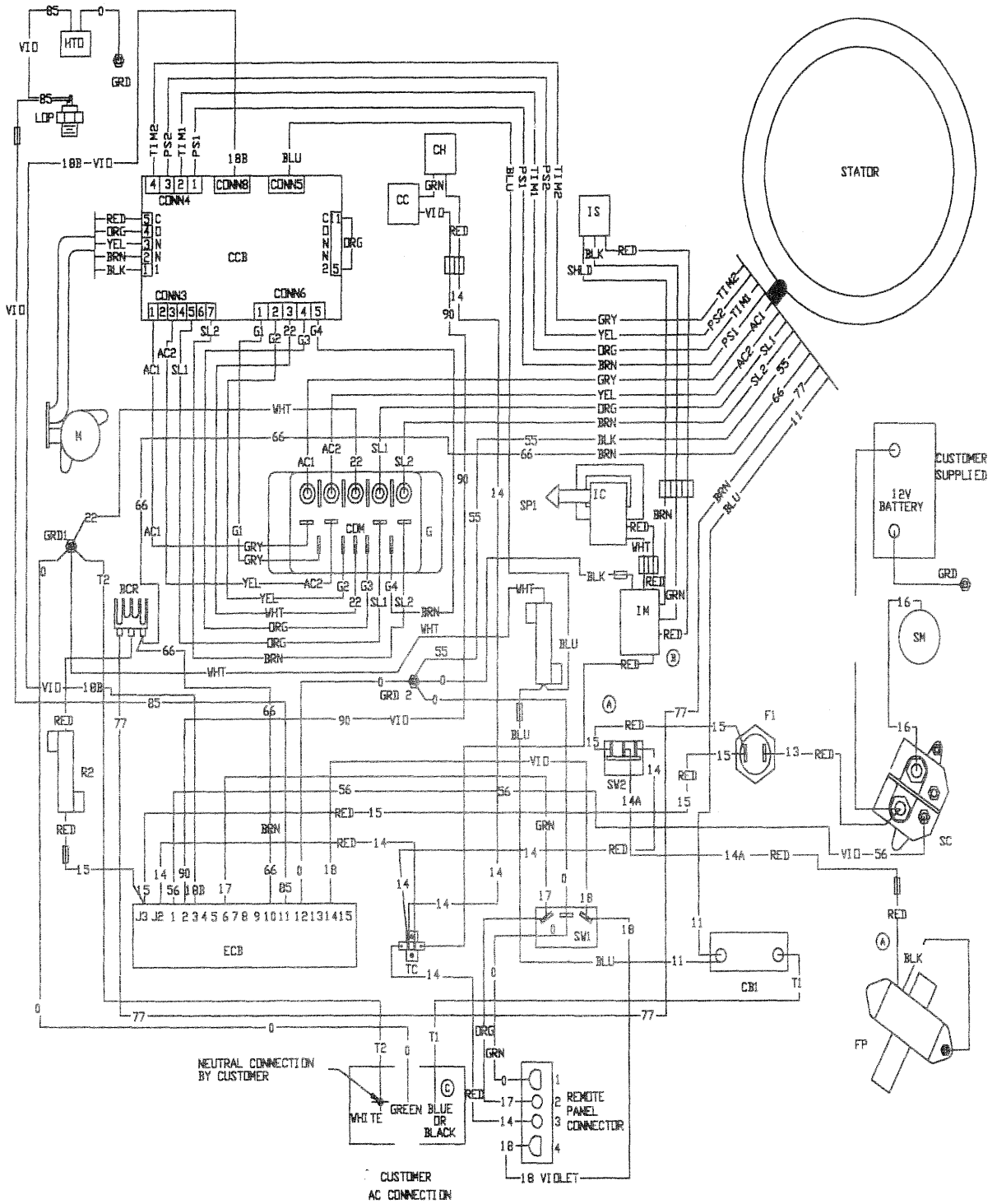

EXPLODED VIEW — LONG BLOCK

Drawing No. 95287

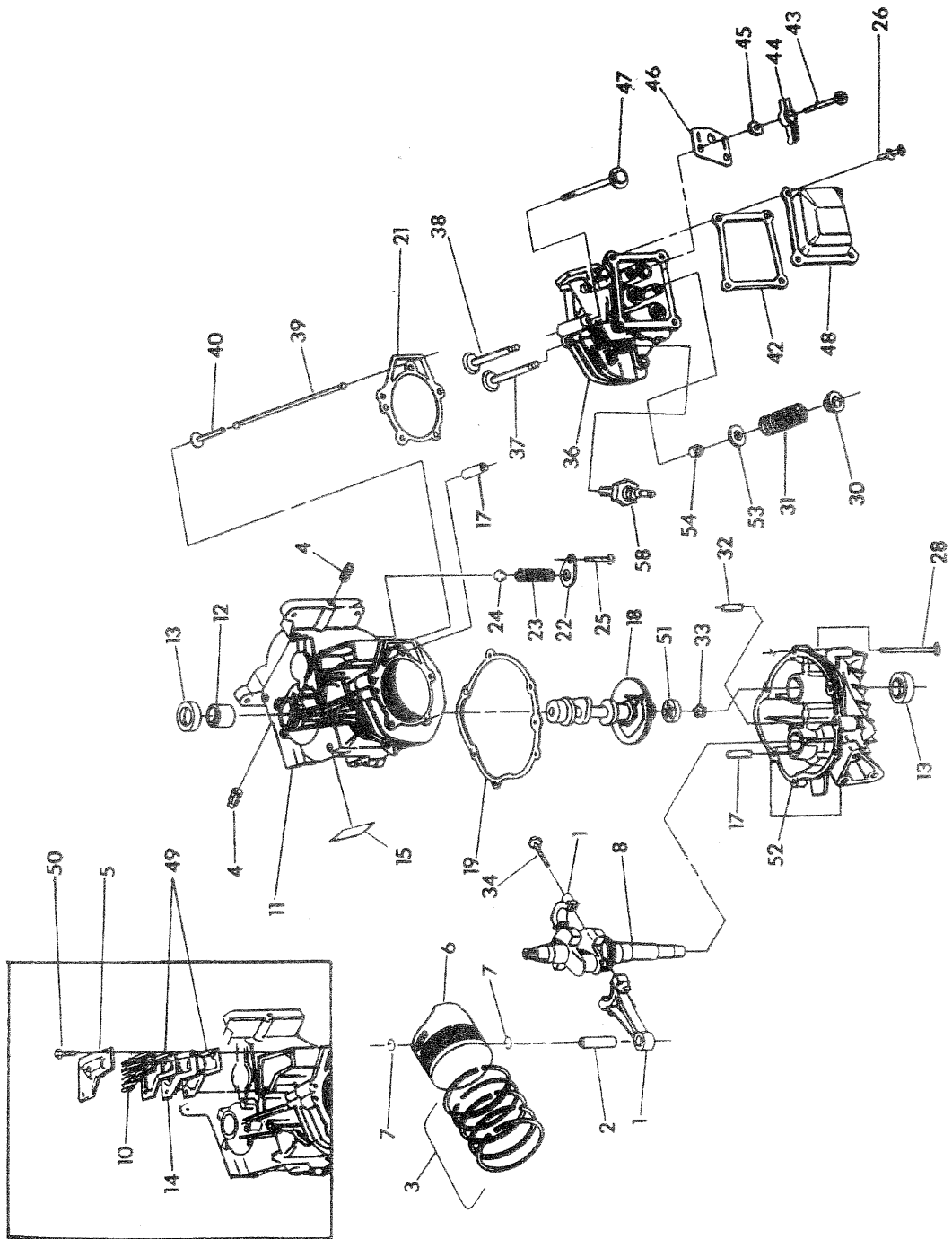

REPAIR PARTS — LONG BLOCK

Drawing No. 95287

ITEM	PART NO.	QTY.	DESCRIPTION
1	76380	1	ASSEMBLY, CONNECTING ROD, CAP & BOLTS
2	76389	1	PISTON PIN
3	88411	1	SET, PISTON RING (STD. SIZE)
4	72657	2	PIPE PLUG-1/4 NPT
5	77176	1	COVER, BREATHER
6	88057	1	PISTON, 75 DIA.
7	76390	2	RETAINER, PISTON PIN
8	83378	1	ASSEMBLY, CRANKSHAFT AND GEAR
10	89923	1	SEPARATOR, OIL BREATHER
11	89213C	1	ASSEMBLY, CRANKCASE
12	76349	1	BEARING, SLEEVE
13	81695	2	SEAL, OIL-CRANKSHAFT
14	90604	1	CUP, BREATHER BAFFLE
15	20527	1	DECAL, ENGINE IDENTIFICATION
17	78699B	3	SLEEVE, DOWEL Ø 12
18	92635	1	ASSEMBLY, CAMSHAFT
19	89096	1	GASKET, CRANK CASE FLANGE
21	88058	1	GASKET, CYLINDER HEAD
22	78691	1	RETAINER, OIL PRESSURE SPRING
23	76367	1	SPRING, OIL PRESSURE
24	76362	1	BALL, OIL PRESSURE
25	78692	1	BOLT, THREAD FORMING-M5
26	78606	4	SCREW & LOCK WASHER, M6-1 x 12 LONG
28	89230	6	HHFC, M8-1.25 x 35 LONG
30	86293	2	RETAINER, VALVE SPRING
31	88401	2	SPRING, VALVE
32	88590	1	DOWEL PIN, Ø 10 x 20 LONG
33	83152	1	GEROTOR, INNER
34	76381	2	BOLT, CONNECTING ROD
36	88404B	1	ASSEMBLY, CYLINDER HEAD W/GUIDES & SEATS
37	90082	1	VALVE, EXHAUST
38	90081	1	VALVE, INTAKE
39	88396A	2	PUSH ROD
40	83235	2	TAPPET
42	96362	1	GASKET, ROCKER COVER
43	77161	2	STUD, BALL PIVOT
44	77160	2	ROCKER ARM
45	76307	2	NUT, ROCKER ARM
46	88403	1	PLATE, PUSH ROD GUIDE
47	77168	5	HEADBOLT, M8 x 52MM
48	88413B	1	COVER, ROCKER
49	78629	2	GASKET, BREATHER
50	90388	2	BOLT, TAPTITE-M6 x 12 LONG
51	83153	1	GEROTOR, OUTER
52	92977	1	ASSEMBLY-SUMP, OIL
53	84186	2	WASHER, WEAR-VALVE SPRING
54	88156	1	SEAL VALVE-INTAKE
58	72347	1	SPARKPLUG, CHAMPION RC12YC

EXPLODED VIEW — GENERATOR

Drawing No. A5970

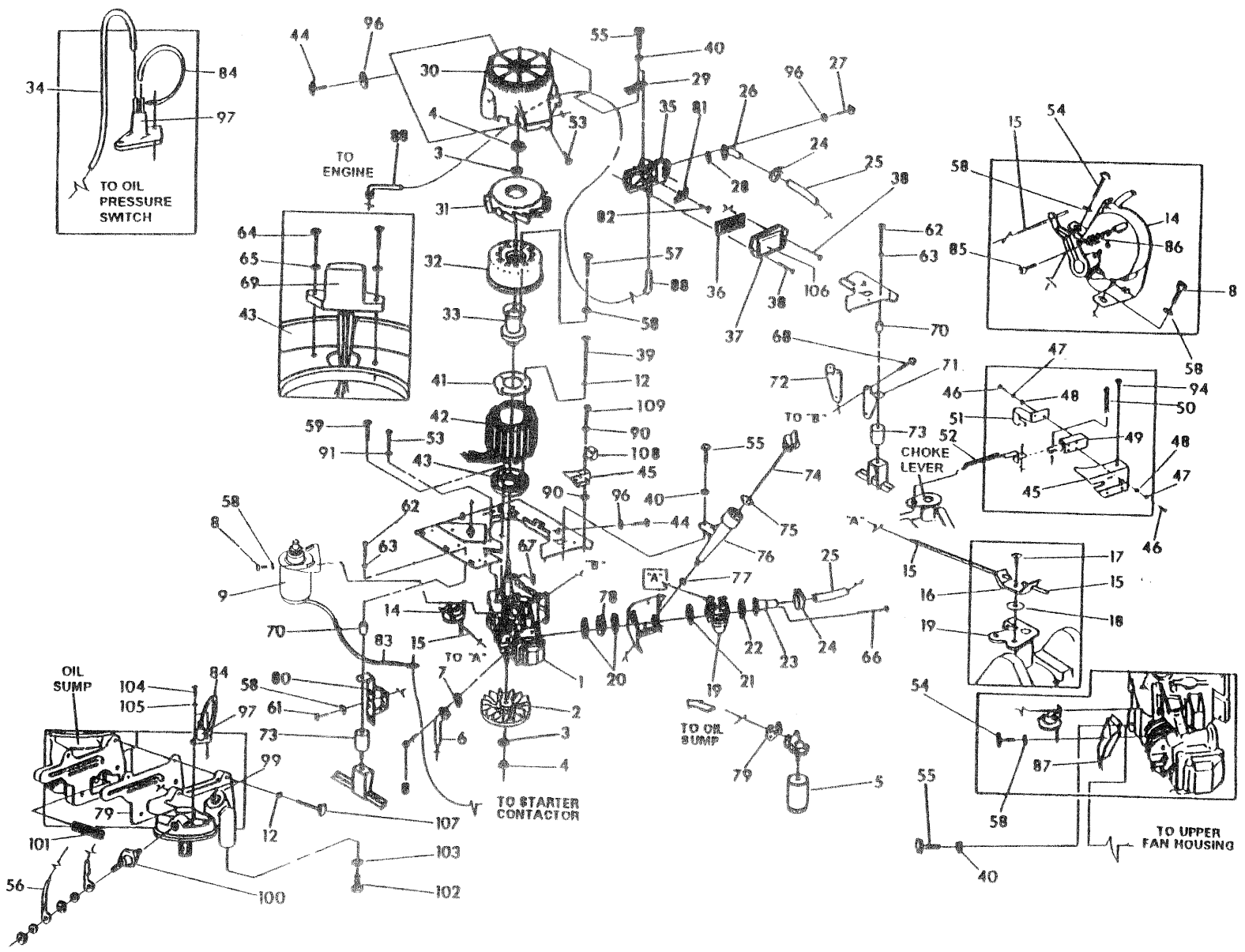

REPAIR PARTS — GENERATOR

Drawing No. A5970

ITEM	PART NO.	QTY.	DESCRIPTION	ITEM	PART NO.	QTY.	DESCRIPTION
1	90306	1	ENGINE, LONG BLOCK	53	45756	4	M6-1 x 10 TAPTITE
2	94583	1	FLYWHEEL, FAN	54	83512	1	TAPTITE M8-1.25 x 15 LG.
3	83312	2	WASHER, CONICAL	55	91526	4	M5 - 0.8 X 12 MM SCREW
4	81810	2	HEX NUT, M16-1.5	56	005-91297	1	OIL PRESS. SWITCH WIRE
5	70185	1	FILTER, OIL	57	42907	3	HEX HD. CAPSCR., M8-1.25 x 16 LONG
6	86730	1	TUBE, EXHAUST OUTLET	58	22129	11	LOCKWASHER-M8
7	89476	1	GASKET, EXHAUST	59	74906	4	HEX HD. CAPSCR., M6-1 x 20LG. TAPTITE
8	40976	4	SOCKET HD. CAPSCR., M8-1.25 x 20 LG	61	39253	3	HEX HD. CAPSCR., M8-1.25 x 20 LONG
9	99948	1	STARTER, EATON/GENERAC	62	22511	3	HEX HD. CAPSCR., 3/8-16 x 1.25" LONG
11	22127	1	NUT, 1/4-20	63	22237	3	LOCKWASHER-3/8
12	22097	9	LOCKWASHER, 1/4-M6	64	55822	2	PHMS, M4- .7 x 8 LONG
14	92059	1	STEPPER MOTOR SPEED CONTROL	65	22264	2	LOCKWASHER-M4
15	86706	1	ROD, THROTTLE CONTROL	66	89050	2	PHILLIPS PAN HD. MACH. SCR.-M6-1 x 90 LONG
16	89477	1	CLIP, ADJUSTMENT	67	82774	1	WOODRUFF KEY-4 x 19
17	89478	1	SNAP, RETAINING	68	59637	4	TAPTITE 3/8"-16 x .75" LG
18	90192	1	WASHER, CARBURETOR	69	86697	1	ASSY. IGNITION SENSOR
19	90881A	1	ASSY., CARBURETOR	70	86704	3	SPACER, ENG. MOUNT
20	90051	2	GASKET, CARB./SPACER/HEAD	71	86701	1	BRCKT., ENG. MNT FRONT
21	78631	1	GASKET, CARB./SKIRT	72	86702	1	BRCKT., ENG. MNT. REAR
22	96459	1	GASKET, CARB./INLET ADAPTOR	73	38353	3	RUBBER MOUNTS
23	86709	1	ADAPTOR, CARB. INLET	74	89263	1	ASSY., OIL FILL CAP
24	35586	2	HOSE CLAMP-BAND 1.50"	75	90071	1	O-RING, 1.062" I.D.
25	86710	1	HOSE, CARB. INLET	76	94637	1	OIL FILL TUBE
26	87993	1	ELBOW, AIR CLEANER OUTLET	77	90072	1	O-RING .562" I.D.
27	49815	2	HEX HD. CAPSCR., M5-.8 x 16	78	86708	1	CARBURETOR SPACER
28	90536	1	GASKET, AIR CLEANER OUTLET	79	87478	1	GASKET, OIL FILTER ADAPTOR
29	90021	1	BRACKET, AIR CLEANER SUPPORT	80	96627	1	BRCKT., STARTER SIDE ENGINE MNT.
30	94665	1	HOUSING, FAN-UPPER	81	90613	1	COVER, BREATHER CANAL
31	93859	1	FAN, GENERATOR	82	59635	1	#8 x 3/8 PLASTITE SCREW
32	A5892	1	ASS., MAGNET HOUSING	83	002-91297	1	STARTER WIRE
33	91437	1	HUB, MAGNET HOUSING ASSEMBLY	84	004-91297	1	TEMP SWITCH GROUND WIRE
34	003-91297	1	TEMP SWITCH WIRE	85	59636	1	PLASTITE SCREW, #4 x .37 LONG
35	86673	1	BASE, AIR BOX	86	88905	1	EXTENSION SPRING
36	78601	1	ELEMENT, AIR FILTER	87	92800	1	WRAPPER, ENGINE TOP
37	86674	1	COVER, AIR BOX	88	89062	1	HOSE, BREATHER
38	78609	2	BOLT, AIR CLNR. COVER	90	23762	3	WASHER, EXTERNAL SHAKEPROOF-#10
39	66449C	4	HEX HD. CAPSCR., M6-1 x 80	91	22447	3	WASHER, INTERNAL SHAKEPROOF, .25"
40	49226	4	LOCKWASHER, M5	94	23484P	1	SNAP BUSHING
41	80934	1	RETAINING RING, STATOR	96	23897	5	#10-M5 FLAT WASHER
42	A5898	1	STATOR ASSEMBLY	97	94090	1	SWITCH-THERMAL, OIL TEMP.
43	86692	1	ADAPTOR, STATOR	99	86675A	1	ADAPTOR, OIL FILTER
44	74908	3	TAPTITE, M5-0.8 x 10	100	77667	1	SWITCH, OIL PRESSURE
45	86735	1	COVER, CHOKE MOUNT	101	86714	1	SCREEN, OIL PICK-UP
46	47488	4	SCREW, 4-40 x .188"	102	52617	1	DRAIN PLUG, M12 x 1.75" LG
47	22159	4	LOCKWASHER-NO. 4	103	94643	1	GASKET, OIL DRAIN PLUG
48	31879	4	FLATWASHER-NO. 4	104	74027	2	SCREW, M3 x 5" LONG
49	91306	1	SOLENOID, CHOKE	105	43182	2	LOCKWASHER, M3
50	36544	1	PIN, COTTER 3/32" x 1/2" LONG	106	90387	1	AIR CLEANER DECAL
51	89473	1	ASSY. BI-METAL & HEATER	107	92079	4	HEX HD. TAPTITE M6-1 x 25 LG
52	86736	1	LINKAGE, CHOKE CONTROL	108	A5620	1	TIME DELAY FILTER
				109	66849	2	TAPTITE, M5-0.8 x 16

EXPLODED VIEW — SHEET METAL

Drawing No. 20741

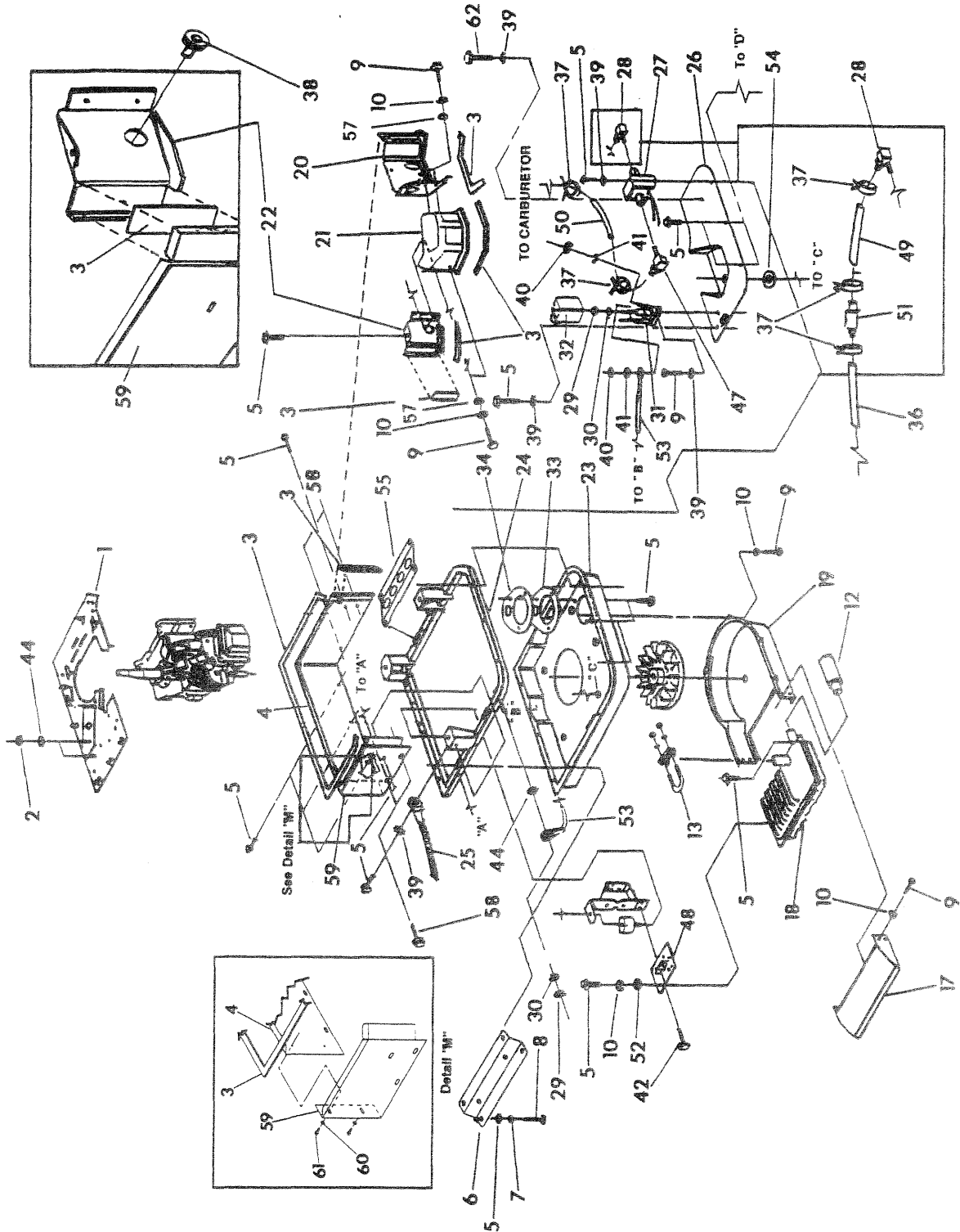

REPAIR PARTS — SHEET METAL

Drawing No. 20741

ITEM	PART NO.	QTY.	DESCRIPTION
1	86705	1	PLATE, DIVIDER
2	49813	2	M6-1.0 HEX NUT
3	86718	1	SEAL RUBBER EXTRUSION
4	A3666	1	WRAPPER, BOX
5	74908	22	TAPTITE, M5-0.8 x 10 LONG
6	20150	1	CUSTOMER MOUNTING RAILS
7	22129	4	LOCK WASHER- M8
8	39414	4	HEX HD. CAPSCR., M8 -1.25 x 35 LG
9	45770	10	HEX HD. CAPSCR., M5- 0.8 x 10
10	49226	18	LOCK WASHER - M5
12	89680	1	SPARK ARRESTOR
13	94670	1	U-BOLT, W / SADDLE & NUTS
17	89471	1	DEFLECTOR, AIR OUT
18	86731A	1	ASSEMBLY, MUFFLER
19	86715	1	HOUSING, LOWER FAN
20	86726	1	SKIRT, CARB. BAFFLE
21	86671	1	COVER, ROCKER
22	86727	1	SPARK PLUG SIDE
23	86719	1	PAN, BELLY
24	20519	1	FRAME
25	90141A	1	GROUND STRAP
26	86724	1	PLATE, BASE COVER
27	90475	1	PUMP, FUEL
28	28740	1	BARBED 90 1/8" x 1/4"
29	22127	3	HEX NUT, 1/4-20
30	22097	3	LOCK WASHER- 1/4"- M6
31	86729	1	CONTACTOR, STARTER
32	90518	1	BOOT, CONTACTOR
33	89048	1	SEAL, OIL FILTER HOLE
34	90537	1	RETAINER, SEAL
35	22145	4	FLAT WASHER- M8
36	30340	1	1/4" FUEL LINE - 4" LONG
37	48031C	5	1/4" HOSE CLAMP
38	23484D	1	SNAP BUSHING
39	23762	9	EXTERNAL SHAKEPROOF
40	22471	2	#8 HEX NUT
41	22264	2	#8 LOCK WASHER
42	79246	2	HEX HD. CAPSCR., M-6 -1.0 x 16 LONG W / LOCKWASHER
44	22447	3	WASHER, INTERNAL SHAKEPROOF, 1/4"-M6
47	39450	1	1/8" x 3/16" NPT 90 DEG. BARBED FITTING
48	92000	1	BRACKET, MUFFLER HANGER
49	30340	1	1/4" FUEL LINE (8" LONG)
50	82580D	1	3/16" CARBURETOR LINE (4" LONG)
51	86311	1	FUEL FILTER
52	51713	4	M5 PLAIN WASHER
53	007-91297	1	STARTER CONTACTOR GROUND WIRE
54	89045	1	SEAL, WASHER EXHAUST PIPE
55	20149	1	CUSTOMER MOUNTING RAIL
56	91526	4	M5 - 0.8 x 12 MM CAPSCREW
57	23897	4	M5 FLATWASHER
58	75494	7	#10 -16 x 5/8, SELF DRILLING SCREW
59	A3638	1	WRAPPER, END PANEL
60	22159	2	#10 LOCK WASHER
61	56893	2	CRIMPTITE, 10-24 x 1/2"
62	A5767	1	HEX HD. CAPSCR., M5-0.8 x 6 LG

REPAIR PARTS — CONTROL PANEL

Drawing No. 20740

ITEM	PART NO.	QTY.	DESCRIPTION	ITEM	PART NO.	QTY.	DESCRIPTION
1	91526	10	M5-0.8 x 12MM PHILLIPS PAN HD. MACH. SCR.	34	43182	4	LOCK WASHER-M3
2	20093	1	BOX, CONTROL TOP	35	89744	1	RESISTOR, POWER 1 OHM
3	20092	1	BOX, CNTL. PANEL	36	83491	1	RESISTOR, POWER 500 OHM
4	36937	2	#10-32 x 1" PHILLIPS PAN HD. MACH. SCR.	37	45756	4	TAPTITE M6- 1 x 10LG.
5	75476	5	PHILLIPS PAN HD. MACH. SCR., M4 x 16	38	86722	1	BRACKET, HEAT SINK-PCB
6	74908	8	TAPTITE M5- .8 x 10 LONG	40	51716	2	HEX NUT-M5
7	23484M	1	SNAP BUSHING	41	75210A	1	TERMINAL BLOCK
8	20107	1	90É CONNECTOR	42	91281	1	12 PIN CON. ASSY.
9	92234	1	RV CONTROL BOARD	43	86738A	1	TRIAC MODULE HARNESS
10	90145	1	CIR. BREAKER, 30A.	44	001-91297	1	GROUND WIRE
11	22097	2	LOCK WASHER-M6	45	91282A	1	CUSTOMER WIRE HARNESS
12	86711	1	IGNITION MODULE	46	91269A	1	REMOTE PANEL HARNESS
13	49226	12	LOCK WASHER-M5	47	23484D	1	SNAP BUSHING
14	51715	2	HEX NUT-M4	48	82121A	2	CLAMP, CONTROL PANEL HARNESS
15	49813	2	HEX NUT- M6	49	20106	1	HARNESS, CONTROL PANEL (NOT SHOWN FOR CLARITY)
16	89049	1	ASSEMBLY, COIL	50	25105	2	#6-32 x 1/4" PHILLIPS ROUND HD. MACH. SCREW
17	89047	2	SPACER, IGNITION COIL MOUNT	51	84867	4	RUBBER U-CHANNEL
18	22985	4	M4 FLAT WASHER	52	51718	4	M4-0.7 x 10MM HEX HD. CAPSCREW
19	23897	8	M5 FLAT WASHER	53	77604	1	HOUR METER
20	20091	1	CNTL. PANEL, FRONT	54	34028	2	#4-40 X 3/8 LG ROUND HD
21	23484E	1	SNAP BUSHING	55	22159	2	#4 LOCKWASHER
22	87798	1	SWITCH, SPDT ROCKER	56	27771	2	#4-40 HEX NUT
23	92113	1	SWITCH, SPSTMOM ROCKER	57	36933	2	PPHMS 10-32 x 3/8" LG.
24	22676	1	FUSE, 15A. AGC	58	21532	1	CONDUIT, 1/2"
25	32300	1	FUSE HOLDER	59	A1491	1	CONN. 1/2"
26	80939	1	EXTRUSION, CONTROLLER	60	23762	2	SHAKEPROOF LOCK WASHER, EXTERNAL TOOTH #10
27	65795	1	RECTIFIER, BATTERY CHARGE	62	29333A	1	BLACK TIE WRAP, 7" LG
28	22264	14	LOCK WASHER-M4				
29	22158	2	#10-32 HEX NUT				
30	20105B	1	PANEL DECAL				
31	86275	1	GENISTOR, TRIAC MODULE				
32	83492	1	ASSEMBLY, PCB CCG				
33	43181	4	TAPTITE, M3-0.5 x 10MM PAN HD. MACH. SCR.				

CALIFORNIA EMISSION CONTROL WARRANTY STATEMENT

YOUR WARRANTY RIGHTS AND OBLIGATIONS

The California Air Resources Board ("CARB") and Generac Corporation are pleased to explain the Emission Control System Warranty on your new recreational vehicle equipment engine. In California, new utility and lawn and garden equipment engines must be designed, built and equipped to meet the State's stringent anti-smog standards. Generac Corporation will warrant the emission control system on your recreational vehicle equipment for the periods of time listed below provided there has been no abuse, neglect, unapproved modification, or improper maintenance of your recreational vehicle equipment engine.

Your emission control system may include parts such as the carburetor, ignition system and exhaust system. Also included may be the compression release system and other emission-related assemblies.

Where a warrantable condition exists, Generac Corporation will repair your recreational vehicle equipment engine at no cost to you for diagnosis, parts and labor.

MANUFACTURER'S EMISSION CONTROL SYSTEM WARRANTY COVERAGE:

Emissions control systems on 1995 and later model year utility and lawn and garden equipment engines are warranted for two years as hereinafter noted. If, during such warranty period, any emission-related part on your engine is defective in materials or workmanship, the part will be repaired or replaced by Generac Corporation.

OWNER'S WARRANTY RESPONSIBILITIES:

As the recreational vehicle equipment engine owner, you are responsible for the performance of the required maintenance listed in your owners manual. Generac Corporation recommends that you retain all receipts covering maintenance on your recreational vehicle equipment engine, but Generac Corporation will not deny warranty solely due to the lack of receipts or for your failure to provide written evidence of the performance of all scheduled maintenance.

As the recreational vehicle equipment engine owner, you should, however, be aware that Generac Corporation may deny you warranty coverage if your recreational vehicle equipment engine or a part thereof has failed due to abuse, neglect, improper maintenance or unapproved modifications.

You are responsible for presenting your recreational vehicle equipment engine to a Generac Corporation Authorized Service Outlet as soon as a problem exists. The warranty repairs should be completed in a reasonable amount of time, not to exceed 30 days.

Warranty service can be arranged by contacting either a Generac Corporation Authorized Service Outlet or by contacting Generac Corporation at:

GENERAC CORPORATION PH: (414) 544-4811
P.O. BOX 8 FX: (414) 544-0179
WAUKESHA, WI 53187

IMPORTANT NOTE: This warranty statement explains your rights and obligations under the Emission Control System Warranty ("ECS Warranty") which is provided to you by Generac Corporation pursuant to California law. See also the Generac Corporation Limited Warranties for Generac Corporation which is enclosed herewith on a separate sheet and also is provided to you by Generac Corporation. The ECS Warranty applies only to the emission control system of your new engine. To the extent that there is any conflict in terms between the ECS Warranty and the Generac Corporation Warranty, the ECS Warranty shall apply except in any circumstances in which the Generac Corporation Warranty may provide a longer warranty period. Both the ECS Warranty and the Generac Corporation Warranty describe important rights and obligations with respect to your new engine.

Warranty service can only be performed by a Generac Corporation Authorized Service Outlet. At the time of requesting warranty service, evidence must be presented of the date of the sale to the original purchaser. The purchaser shall pay any charges for making service calls and/or for transporting the products to and from the place where the inspection and/or warranty work is performed. The purchaser shall be responsible for any damage or loss incurred in connection with the transportation of any engine or any part(s) thereof submitted for inspection and/or warranty work.

IF YOU HAVE ANY QUESTIONS REGARDING YOUR WARRANTY RIGHTS AND RESPONSIBILITIES, YOU SHOULD CONTACT GENERAC CORPORATION AT 1-800-222-3136

EMISSION CONTROL SYSTEM WARRANTY

Emission Control System Warranty ("ECS Warranty") for 1995 and Later Model Year Utility and Lawn and Garden Equipment Engines:

- A. **Applicability:** This warranty shall apply to 1995 and later model year utility and lawn and garden equipment engines. The ECS Warranty Period ("ECS Warranty Period") shall begin on the date the new engine or equipment is delivered to its original, end-use purchaser and shall continue for 24 consecutive months thereafter.
- B. **General Emissions Warranty Coverage:** Generac Corporation warrants to the original, end-use purchaser of the new engine or equipment and to each subsequent purchaser that each of its utility and lawn and garden equipment engines is:
1. Designed, built and equipped so as to conform with all applicable regulations adopted by the Air Resources Board pursuant to its authority, and
 2. Free from defects in materials and workmanship which, at any time during the ECS Warranty Period, will cause a warranted emissions - related part to fail to be identical in all material respects to the part as described in the engine manufacturer's application for certification.
- C. The ECS Warranty only pertains to emissions-related parts on your engine, as follows:
1. Any warranted, emissions-related parts which are not scheduled for replacement as required maintenance in the Owner's Manual shall be warranted for the ECS Warranty Period. If any such part fails during the ECS Warranty Period, it shall be repaired or replaced by Generac Corporation according to Subsection (4) below. Any such part repaired or replaced under the ECS Warranty shall be warranted for any remainder of the ECS Warranty Period.
 2. Any warranted, emissions-related part which is scheduled only for regular inspection as specified in the Owner's Manual shall be warranted for the ECS Warranty Period. A statement in such written instructions to the effect of "repair or replace as necessary" shall not reduce the ECS Warranty Period. Any such part repaired or replaced under the ECS Warranty shall be warranted for any remainder of the ECS Warranty Period.
 3. Any warranted, emissions-related part which is scheduled for replacement as required maintenance in the Owner's Manual shall be warranted for the period of time prior to first scheduled replacement point for that part. If the part fails prior to the first scheduled replacement, the part shall be repaired or replaced by Generac Corporation according to Subsection (4) below. Any such emissions-related part repaired or replaced under the ECS Warranty shall be warranted for the remainder of the ECS Warranty Period prior to the first scheduled replacement point for such emissions-related part.
 4. Repair or Replacement of any warranted, emissions-related part under this ECS Warranty shall be performed at no charge to the owner at a Generac Corporation Authorized Service Outlet.
 5. The owner shall not be charged for diagnostic labor which leads to the determination that a part covered by the ECS Warranty is in fact defective, provided that such diagnostic work is performed at a Generac Corporation Authorized Service Outlet.
 6. Generac Corporation shall be liable for damages to other original engine components or approved modifications proximately caused by a failure under warranty of any emission-related part covered by the ECS Warranty.
 7. Throughout the ECS Warranty Period, Generac shall maintain a supply of warranted emission-related parts sufficient to meet the expected demand for such emission-related parts.
 8. Any Generac Corporation authorized and approved emission-related replacement part may be used in the performance of any ECS warranty maintenance or repairs and will be provided without charge to the owner. Such use shall not reduce Generac Corporation ECS warranty obligations.
 9. Unapproved add-on modified parts may not be used to modify or repair a Generac Corporation engine. Such use voids this ECS Warranty and shall be sufficient grounds for disallowing an ECS Warranty claim. Generac Corporation shall not be liable hereunder for failures of any warranted parts of a Generac Corporation engine caused by the use of such an unapproved add-on or modified part.

EMISSION RELATED PARTS INCLUDE THE FOLLOWING:

1. Carburetor assembly and its internal components.
 - a. Fuel filter
 - b. Carburetor gaskets
 - c. Fuel pump (if so equipped)
2. Air cleaner assembly
 - a. Air filter element
 - b. Intake pipe/manifold
3. Ignition system including:
 - a. Spark plug
 - b. Ignition module
4. Catalytic muffler (if so equipped)
 - a. Muffler gasket (if so equipped)
 - b. Exhaust manifold (if so equipped)
5. Crankcase breather assembly and its components.
 - a. Breather connection tube

GENERAC'S THREE - YEAR LIMITED WARRANTY FOR RECREATIONAL VEHICLE NP GENERATORS

Generac warrants to the original purchaser that its generators will be free from defects in materials or workmanship for the period set forth below from date of original purchase. During said warranty period, Generac will, at its option, repair or replace any part which, upon examination by Generac or Generac Authorized Distributors and/or Dealers, is found to be defective under normal use and service.

THREE - YEAR WARRANTY SCHEDULE

1. All NP series generators used in a recreational vehicle shall be warranted for a period of three (3) years or 2,000 hours of operation, whichever occurs first. All parts, labor, removal and reinstallation shall be covered for the first two years. Parts and labor on selected generator and engine parts shall be covered during the third year or 2,000 hours, whichever occurs first. These selected parts are limited to: the main Rotor and Stator, Computer Control Board (if applicable) with regard to the generator; the Cylinder Block, Cylinder Head, Crankshaft, Piston, Valve, Valve Lifter, and Manifolds with regard to the engine.
2. The drive train belt and pulleys on NP air-cooled generators (if applicable) used in recreational vehicles shall be warranted against failure due to defective materials or normal usage for the life of the generator. For the original owner, this drive train warranty shall include parts and labor plus \$50.00 payment upon return of the failed belt or pulley by the original owner. For succeeding owner, this power train warranty shall cover belt or pulley parts only.
3. Rental units, demonstrators, prime power, or commercial applications, such as construction or utility, are warranted for (1) one year or 2,000 hours, whichever comes first.

THIS WARRANTY DOES NOT COVER:

- Costs of maintenance, installation and startup.
- Failures due to (a) normal wear and tear from GN engine, or (b) accident, misuse, abuse, negligence or improper installation.
- Products which are modified or altered in a manner not authorized by Generac in writing.
- Any accidental, consequential or indirect damages caused by defects in materials or workmanship, or any delay in repair or replacement of defective parts.
- Failure due to misapplication.
- Telephone, telegraph, teletype or other communication expenses.
- Living or travel expenses of persons performing service.
- Any and all transportation/travel expenses.
- Rental equipment used while warranty repairs are being performed.
- Overtime labor.
- Starting batteries, fuses, light bulbs, and engine fluids.

****NORMAL WEAR:** As with all mechanical devices, engines need periodic parts service and replacement to perform well. This warranty will not cover repair when normal use has exhausted the life of a part or an engine.

THERE IS NO OTHER EXPRESS WARRANTY. GENERAC HEREBY DISCLAIMS ANY AND ALL IMPLIED WARRANTIES, INCLUDING BUT NOT LIMITED TO THOSE OF MERCHANTABILITY AND FITNESS FOR A PARTICULAR PURPOSE TO THE EXTENT PERMITTED BY LAW. THE DURATION OF ANY IMPLIED WARRANTIES WHICH CANNOT BE DISCLAIMED IS LIMITED TO THE TIME PERIOD AS SPECIFIED IN THE EXPRESS WARRANTY. LIABILITY FOR CONSEQUENTIAL, INCIDENTAL, OR SPECIAL DAMAGES UNDER ANY AND ALL WARRANTIES IS EXCLUDED. Some states do not allow limitations on how long an implied warranty lasts, or the exclusion or limitation of incidental or consequential damages, so the above limitations or exclusions may not apply to you. This warranty gives you specific legal rights and you may also have other rights, which vary from state to state.

For service, see your nearest GENERAC authorized warranty service facility or call 1-800-333-1322. Warranty service can be performed only by a GENERAC authorized service facility. This warranty will not apply to service at any other facility. At the time of requesting warranty service, evidence of original purchase date must be presented.

GENERAC CORPORATION® P.O. BOX 8 Waukesha, WI 53187
TELEPHONE: (414) 544-4811 FAX: (414) 544-4851