



Cummins Power Generation
1400 73rd Avenue NE
Minneapolis, MN 55432
1-800-888-ONAN
Fax (763) 528-7242
www.funroads.com

Owner's Handbook

for the world's most-trusted RV generators.



©2005 Cummins Power Generation. Onan is a registered trademark of Cummins Inc. "The quiet one" is a service mark of Cummins Inc.

TABLE OF CONTENTS

INTRODUCTION	2
I. RV GENERATOR OPERATION	
• Load Management Basics	4
• Common Power Requirements Chart	5
• Operating Motor Driven Appliances	8
• Air Conditioner “Short-Cycling”	8
• Effects Of High Altitude And Extreme Temperatures	8
• Starting And Stopping Procedures	9
• Breaking In Your New Generator	9
• Exercising Your Generator	9
• Preventing Surging	10
• Noise Level Comparison Chart	11
II. IMPORTANT SAFETY PRECAUTIONS	
• Fundamental Safety Rules	12
III. GENERATOR CARE AND MAINTENANCE	
• General Generator Maintenance	13
• RV Generator Manuals Chart	14
• Maintenance Intervals Chart	15
• Do’s And Don’ts For Better Generator Performance	16
• Service Point Diagrams	17
• Keep Your Generator Clean And Inspected For Damage	23
• Fuel Recommendations	23
• A Word About Oil	24
• Prevent Fuel Varnishing	25
• Troubleshooting Guide	26
IV. GENERATOR MAINTENANCE: PARTS AND CHEMICALS	
• Insist On The Quality Of Green Label Parts™	27
• Use Onan® Oil And Service/Maintenance Chemicals To Insure Performance	29
• Green Label Parts Chart	30
V. WARRANTY AND SERVICE	
• Standard 3-Year Limited Warranty With Available 5-Year Extended Coverage	34
• Largest Authorized Service And Parts Dealer Network In The Industry	34
• Coach Care™ Service Centers	35
VI. CAMP POWER AND ONAN RV GENERATOR MODELS	
• Camp Power™	40
• MicroLite™ And MicroQuiet™	42
• Emerald Advantage™	44
• Marquis Gold™	46
• Marquis Platinum™	48
• Quiet Diesel™	50
VII. ENERGY COMMAND	
• Energy Command	52
VIII. ONAN EQUINOX	
• Onan Equinox	54
IX. FREQUENTLY ASKED QUESTIONS	56



INTRODUCTION

Thank you for choosing an Onan® or Camp Power™ generator – the best selling line of installed generators in the history of the RV industry.

Whether you're driving through the Arizona desert, climbing the Rocky Mountains, or parked quietly by the coast or lakeside, owning an Onan or Camp Power RV generator lets you take advantage of practically every pleasure and modern convenience you enjoy at home. A generator combines a gasoline, diesel or LP liquid- or vapor-powered engine with an electrical generator to provide an independent power source totally separate from the main engine of your RV. Your Onan or Camp Power generator produces the electrical power to operate a variety of items inside and outside your RV, including air conditioners, hair dryers, coffee makers, televisions, microwaves and even power tools.

For over 80 years, Onan has set the standard for quiet, reliable RV power. With the growing network of 30 Coach Care facilities and the establishment of Camp Power – the first line of installed generators for the towable RV market – we continue to stand for quality, innovation and unsurpassed service to our family of customers.

All Onan and Camp Power generators undergo vigorous factory testing to meet strict quality standards. In fact, our extensive product-testing program sets the standard for the industry.

This Handbook was created to assist you as a valuable source of information. It contains technical specifications, as-well-as general information and tips on keeping your Onan or Camp Power generator running at peak performance. We suggest you familiarize yourself with the contents of the Handbook and keep it accessible for quick reference.

Our promise is to continue providing the best RV generators you can buy and to keep you supported by the best-trained service organization in the business.

By following the tips contained in this handbook and having an Onan Authorized RV Service and Parts Dealer provide service at recommended intervals, your generator will provide reliable, easy-to-own performance for years to come.



I: RV GENERATOR OPERATION

LOAD MANAGEMENT BASICS

To understand how battery chargers, automatic generator start systems and other baseloads affect your generator, you need to be aware of three things:

- 1) Your generator's power capability
- 2) How to manage electrical loads
- 3) Battery charging times

Determining Your Generator's Power Capability

To determine what your generator can power, use the chart on the opposite page to estimate the total combined watts of all the appliances, lamps, battery chargers, air conditioners and other electrical products you typically use at the same time. (All electrical appliances and lights are labeled with their power requirements expressed in watts or amps). You can use any number of appliances simultaneously, as long as their combined wattage doesn't exceed the electrical output of your Onan® or Camp Power™ generator, or your RV's circuit breaker rating.

Common Power Requirements

Appliances	Average Required Wattage	Amps
Air Compressor (1hp)	1500-2000	9-20
Air Conditioner	1400-2400	9-20
Battery Charger	Up to 3000	6-28
Blender	600	5.5
Broiler	1350	12
Broom/Vacuum	200-500	1.5-4
Coffeepot	550-1000	4-8
Compact Disc Player & Speakers	50-100	0.5-0.9
Computer	50-100	0.5-0.9
Converter	500-1000	4-8
Curling Iron	20-50	0.2-0.5
Dishwasher	1400	12
Drill	250-750	2-6
Electric Blanket	50-200	0.5-1.5
Fan	25-100	0.2-0.9
Frying Pan/Wok	1000-1350	8-11
Hair Dryer	350-1500	3-13
Iron	500-1200	4-10
Lightbulbs	40-100 ea.	0.36-0.9
Microwave/Convection Oven	700-1500	6-13
Radio	50-200	0.5-1.5
Refrigerator	400-1000	3-8
Space Heater	1000-1500	8-13
Stove (per element)	350-1000	3-8
Television	200-600	1.5-4
Toaster	750-1200	6.5-10
VCR	150-200	1.15
Washer/Dryer	2000-2250	16
Water Heater	1000-1500	8-13
Water Pump	500-600	4-5

Managing Electrical Loads

If you try to operate too many things at once, you'll "overload" the generator. You'll know because your lights will flicker or the circuit breakers on the generator or the main coach electrical panel will trip open, stopping the flow of power.

Battery charging loads can also overload your generator and you may not realize this is happening because the charging starts automatically. Be aware of how large this "invisible" load can be.

- Air conditioners need "reserve" power to start. Too much baseload can prevent air conditioners from starting.
- Air conditioners typically draw 1400-2400-watts, depending on size and operating conditions (more power is needed at high temperature or humidity). During start-up, air conditioners can draw 3-4 times that amount.
- Battery chargers come on automatically and can draw a large load (up to 3000-watts). Manage your electrical loads by adjusting battery charge rates to best suit your needs. Consult your inverter/charger manual or manufacturer.
- If you have an automatic generator stop/start system, learn how to control it. Consult your inverter/charger manual or manufacturer for adjustment procedures. Adjust battery charge rates to best suit your total electrical needs. This system is not part of an Onan® or Camp Power™ generator.
- Disable auto-start systems while refueling, servicing, storing or long-term parking.

NOTE: The generator will continue to run after a circuit breaker trips. Turn off all appliances and reset the breaker. If the breaker trips again with all electrical loads off, you may have a short circuit in your wiring. Turn off the generator and contact a qualified electrician.

Battery Charging Loads				
Inverter/Converter Size (Watts)	Battery Charger Max Output (14vdc)	Amps Required From Generator (at 120VAC)	Watts	Equivalent Appliance Load Example
1000	50 Amps	12A	1440	Hi-efficiency AC or microwave
1500	75 Amps	16A	1920	Hi-efficiency AC plus microwave
2000	100 Amps	21A	2520	11000 AC plus microwave
2500	120 Amps	26A	3120	13500 AC plus microwave
3000	140 Amps	28A	3360	11000 AC plus 13500 AC

EXAMPLE: Dashed box shows that a 2000-watt inverter running at 100A battery charge capacity creates the same load as an 11000 BTU air conditioner plus a microwave oven.

Understanding Battery Charging Times

In addition to being aware of battery charging loads, it is important to know that battery charging takes time. The chart below shows how long a 100A charger must run before reaching 100% battery charge.

Battery chargers replenish power drained from:

- engine starting
- generator starting
- appliances working on inverter power like microwave and refrigerator
- mechanicals like slide outs and pumps

NOTE: Table is for a 100A battery charger (typical 2000-watt inverter) pulling 21A (2520-watts) from generator, depending on battery bank size.

Battery Charging Times					
Battery Bank Size (Amp Hours)	Hours That A 100A Battery Charger Must Run To Reach Float Rate Starting From This % Of Battery Charge.				
	80%	60%	40%	20%	0%(11 VDC)
100	0.3	0.7	1	1.3	1.6
200	0.6	1.4	2	2.6	3.2
400	1.2	2.8	4	5.2	6.4
600	1.8	4.2	6	7.8	9.6
800	2.4	5.6	8	10.4	12.8
1000	3.0	7.0	10	13.0	16.0
1200	3.6	8.4	12	15.6	19.2
1500	4.5	10.5	15	19.5	24.0

EXAMPLE: Dashed box shows that using a 100A battery charger, a 600A/hr battery bank at 60% charge level must be charged for 4.2 hours before it is fully charged.

Conditions that increase battery charge times:

- If too many DC loads like pumps and fans are applied, the charger may never catch up with the batteries. The Battery Charging Times Chart assumes no other DC loads are operating.
- 120v air conditioning loads powered through the inverter lengthen charge time due to power sharing. Consult your inverter/charger's manufacturer manual for charge rate control.
- Poor batteries, cables, or connections.

Manage electrical loads to get the most from your generator and electrical system. If you need help, ask your coach dealer for training on how to operate auto-starting systems as well as how to adjust battery charger output. If the dealer can't help, contact inverter/charger or control manufacturer.

OPERATING MOTOR DRIVEN APPLIANCES

When using an appliance with a motor, turn it on and let it reach normal running speed before starting other appliances. Air conditioners, like all electric motors, can draw up to three times more power during start up than during normal operation. While this is true for all electric motors, it can be especially true in air conditioners if the compressor tries to start against built-up high pressure in its refrigeration system.

AIR CONDITIONER “SHORT-CYCLING”

When an air conditioner runs, the compressor builds refrigerant pressure. If the compressor is then shut off, either manually or by satisfying thermostat demand, it must stay off for some period of time, usually 3-4 minutes, to allow pressure in the system to equalize before it can be safely restarted. Trying to restart the air conditioner compressor before pressure equalizes is known as “short-cycling”. If an air conditioner is “short-cycled” the results may be; 1) tripped air conditioner circuit breaker; 2) generator shut down on overload; or 3) tripped air conditioner thermal overload. The air conditioner thermal overload will reset itself after the compressor cools. It cannot be reset manually.

Some, but not all, RV air conditioner thermostats have built-in time delays to prevent short-cycling. Short-cycling occurs in some RVs when the thermostat is mounted so that cold air blows directly on it. If this happens, the thermostat shuts the compressor off before the cabin has cooled, but quickly warms back up and signals the compressor to restart before refrigerant pressure equalizes. In this case, the flow of air from the air conditioner should be directed away from the thermostat, or the thermostat should be relocated. Short-cycling can be prevented by always being sure the air conditioner rests for 3-4 minutes after the compressor shuts off before trying to restart it.

EFFECTS OF HIGH ALTITUDE AND EXTREME TEMPERATURES

If you frequently travel at high altitudes or in extreme temperatures, be aware that your generator can lose power in lower-density air caused by such conditions. You won't be able to operate as many electrical devices in those circumstances as you could under normal operating conditions.

- Power decreases 3.5% for each 1,000 feet above an altitude of 500 feet. For example, to operate at 4,500 feet (4,000 feet above rated generator altitude) multiply $3.5\% \times 4$ (4,000 ft) = 14% power loss. Then multiply $.14 \times$ your generator's power rating. Example, 4,000 watts $\times .14$ = a loss of 560 watts at that altitude.
- Power decreases in extreme temperatures by 1% for each 10°F (5.5°C) above 85°F.

NOTE: The carburetor on a non-EFI gasoline generator may require adjustment at high altitudes. (See your Operator's Manual or your Onan Authorized RV Service and Parts Dealer.)

STARTING AND STOPPING PROCEDURES

Your Onan® or Camp Power™ generator can be started and stopped from the standard control panel on the generator, or from the optional remote control panel inside the vehicle if your RV is so equipped. Your Operator's Manual outlines the simple steps for starting and stopping. Remember to:

- Turn off air conditioners and large electrical loads before starting the generator.
- Turn off all appliances in cold weather before starting for best long-term performance.
- Let the generator warm up for a few minutes before turning on appliances.
- Turn off air conditioners and large electrical loads and let the generator run for 3-5 minutes before stopping, to allow it time to cool down.

BREAKING IN YOUR NEW GENERATOR

Your generator will perform better if you follow the break-in procedure recommended in the Operator's Manual. The break-in process typically involves running the generator at about 50 percent load for two hours, then at about 75 percent load for two hours, then letting it cool down. You should change the engine crankcase oil after the first 20 hours of operation, and every 100 to 150 hours thereafter. (See the Maintenance Chart on page 15 for specific intervals.)

EXERCISING YOUR GENERATOR

It may seem strange that “not” using a machine could cause performance problems, but with RV generators that's exactly the case. Regular “exercise” is an important part of keeping your generator healthy. Lack of exercise can cause moisture build-up and fuel system damage that make it run poorly. In fact, in as little as 30 days, the fuel in gasoline-powered generators can begin to break down into gums and varnishes that clog the fuel system. Fuel varnishing results in hard starting and surging. (A surging generator never settles at a stable operating speed.)

To prevent such problems, we recommend running gasoline generators at a minimum of 50 percent capacity (2000-watts, or one air conditioner for a 4000-watt set) for two hours at least once every four weeks. A long two-hour exercise period is preferable to several short periods.

PREVENTING SURGING

The electrical supply (voltage and frequency) for any appliance must be kept within very close limits for it to work properly. Changes in the electrical supply (called surging) can damage the appliances in your RV. Proper care of your generator will enable it to supply a stable power source and prevent surging.

RV generators control engine speed with a governing system. Most generators have a mechanical governor, although the latest Onan® Marquis Platinum™ and Quiet Diesel™ generators use an electronic governor. Without a governor, as appliances are turned on, engine speed simply drops until the generator finally stops running. With a governor, the carburetor throttle opens to compensate for load, to maintain a constant speed.

The governor works in careful balance with the generator engine, fuel system, regulator and generator. If the balance is upset, surging may result.

A variety of things can cause surging, including an inadequate fuel supply, lack of exercise, and poor maintenance. (See the Troubleshooting Guide on page 26.)

CAUTION: When operating electronic appliances (TVs, computers, VCRs, etc.) in your RV, it is important to use surge protectors to prevent power surges from damaging your equipment. We are not responsible for damage to sensitive electronic equipment.

Tips To Help Prevent Surging

- Be sure the generator has an adequate fuel supply. Fuel is drawn from a remote fuel tank. With gasoline-fueled RVs, it's usually the vehicle's main fuel tank. Typically the generator's fuel pickup extends only ¾ of the way to the bottom of the tank – to keep you from being stranded at your campsite! So just because you have fuel in the tank, you're not guaranteed it's getting to your generator. (If you have two fuel tanks in your vehicle make sure both tanks are full.) An inadequate fuel supply can also be caused by cracked/leaking fuel lines or a defective fuel pump. Contact your local Onan Authorized RV Service and Parts Dealer to have this checked out.
- Be sure to follow the generator exercise recommendations or the out-of-service protection recommendations outlined in your Operator's Manual. Gum and varnish from stale fuel can plug small carburetor passages causing a lean fuel mixture and surging. Treat the fuel system with Green Label Parts Premium Fuel System Cleaner in the clean-up mode ratios. Contact your local Onan Authorized RV Service and Parts Dealer to have the carburetor cleaned and adjusted if the problem persists.
- On carbureted models, be sure carburetor, choke, and governor adjustments are performed by your local Onan Authorized RV Service and Parts Dealer. These adjustments can only be properly made using specialized instruments.
- Be sure ignition system components are in good condition.
- On carbureted models, with manual preheater control lever, be sure the carburetor air pre-heater is in the proper position for temperature and humidity at your location. The selector should be in the winter position if the temperature is below 55°F and/or the humidity is high.

Noise Level Comparison (in decibels)

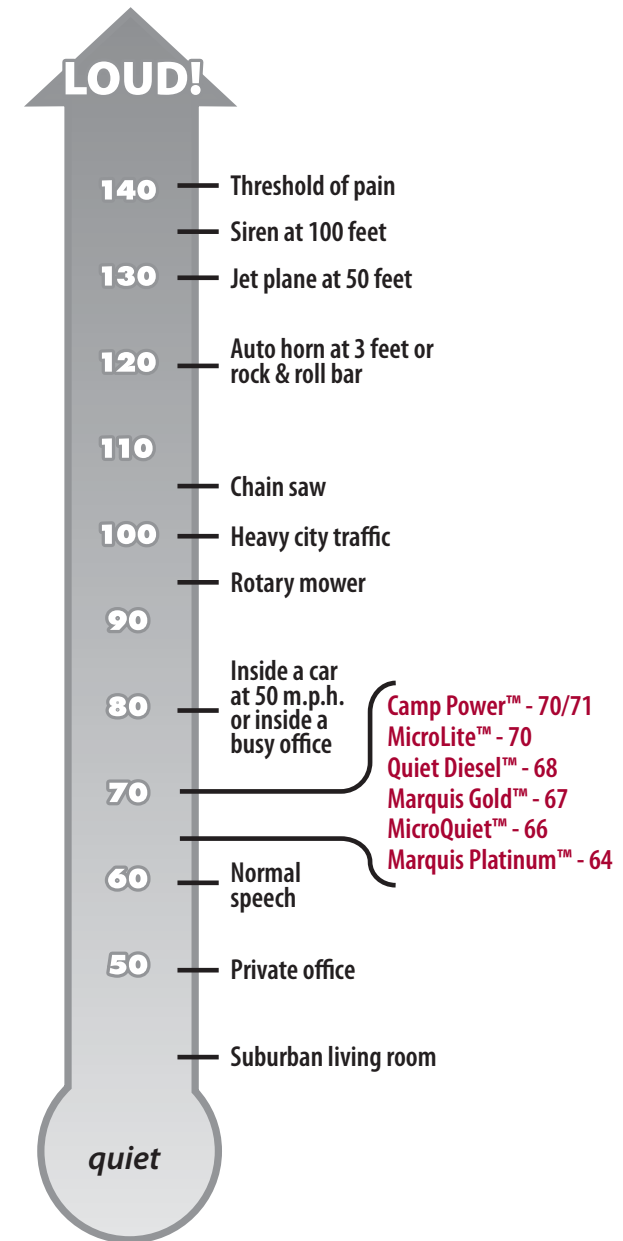



II: IMPORTANT SAFETY PRECAUTIONS

FUNDAMENTAL SAFETY RULES

Please read your generator Operator's Manual carefully so you understand all the precautions for safe, efficient operation. Most accidents occur from failing to follow fundamental safety rules. In general:

- Exhaust gas is deadly. Check all exhaust system connections regularly for leaks and tighten them as necessary. Do NOT operate the generator with a faulty exhaust system.
- If your RV bottoms out on a driveway or road object, inspect the generator exhaust system for damage. The tail pipe must extend past the edge of the vehicle.
- Always operate the generator in an area where the wind will carry away the exhaust fumes.
- Never sleep with the generator running unless the RV is equipped with an operating carbon monoxide detector.
- Don't store anything, especially gas, oil, rags or other flammable materials, in the generator compartment.
- Keep the exhaust and air intake free from obstructions such as clothing, furniture or other material.
- Perform all service and maintenance work with the generator engine off and the positive battery cable disconnected. Moving parts can cause severe personal injury or death, and live wires could cause fatal electrocution.
- Backfeed to utility systems can create serious risks to life or property. Do not connect to building electrical system except through approved device and after building main breaker is opened.

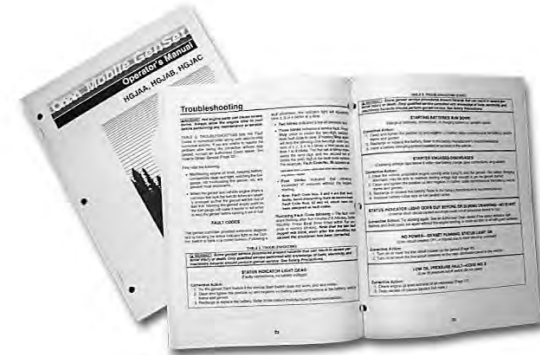

III: GENERATOR CARE AND MAINTENANCE

GENERAL GENERATOR MAINTENANCE

An Onan® or Camp Power™ RV generator is an investment that can bring you many years of comfort and enjoyment. However, all generators require periodic maintenance for dependable, ongoing performance. Your Operator's Manual outlines the specific maintenance procedures and service intervals for your particular model. If you take good care of your generator, it will take good care of you.

RV maintenance is performed according to the number of miles you travel. Similarly, generator maintenance is based on hours of running time. If your generator does not come equipped with an hour meter, install one, and place it in an easy-to-see location near the RV's electrical control panel so you can keep track of the hours your generator runs. The Onan deluxe remote control panel includes an hour meter. The following chart shows the recommended maintenance intervals for Onan and Camp Power generators. These are general guidelines only. Consult the Operator's Manual for procedures and maintenance intervals for a specific model. If you are unable to locate your Operator's Manual, many can be viewed online or purchased at Funroads.com.

- Maintenance charts are in all Operator's Manuals.
- The Onan sets which offer electronic ignition feature longer maintenance intervals. Onan offers a Retrofit Kit, called Magna Arc® for adding electronic ignition to pre-1990 Emerald generators. Contact your local Onan Authorized RV Service and Parts Dealer for more information.
- Check your generator exhaust system each time you start the generator. Make sure it doesn't leak and that it extends beyond the vehicle's perimeter.
- Refer to manual for service intervals for injectors and valve adjustments typically 500-1,000 hours.

RV Generator Manuals						
	Series	Spec Letter	Operators	Parts	Service	Installation
MicroQuiet	KY	A	981-0139	981-0246B	981-0503	981-0627
	KY	B-C	981-0139	981-0246B	981-0503	981-0607
	KY	D-H	981-0154	981-0246B	981-0503	981-0607
	KY	J	981-0159C	981-0246B	981-0530	981-0621
	KY	K	981-0159C	981-0246C	981-0530	981-0621
	KY	L	981-0159C	981-0246D	981-0530	981-0621
	KY Tracker	E-F	981-0155	981-0246B	981-0503	981-0611
Quiet Diesel 10000	HDCAA	A-B	981-0152C	981-0259C	981-0526D	981-0615C
Quiet Diesel 10000	HDCAA	C	981-0170	981-0259D	981-0526D	981-0637
Quiet Diesel 12500	HDCAB	A-B	981-0152C	981-0259C	981-0526D	981-0615C
Quiet Diesel 12500	HDCAB	C	981-0170	981-0259D	981-0526D	981-0637
Quiet Diesel 7500	HDKAJ	A-H	981-0161	981-0200D	981-0522B	981-0623
Quiet Diesel 8000	HDKAK	A-H	981-0161	981-0200D	981-0522B	981-0623
Quiet Diesel 5500	HDKBA	A	981-0166B	981-0271	981-0535	981-0633B
Quiet Diesel 5500	HDKBA	A-C	981-0166B	981-0271B	981-0535	981-0633B
Quiet Diesel 10000	HDKCA Kubota	A	981-0173	981-0277	981-0540	981-0640
Quiet Diesel 12500	HDKCB Kubota	A	981-0173	981-0277	981-0540	981-0640
Marquis Platinum	HGJAA	A-C	983-0101B	983-0201C	983-0501C	983-0600
Marquis Gold	HGJAB	A-C	983-0101B	983-0201C	983-0501C	983-0600
Emerald Advantage	HGJAC	A-C	983-0101B	983-0201C	983-0501C	983-0600
MicroLite	KV	A-B	981-0129	981-0238F	981-0506	981-0626
	KV	C-D	981-0136	981-0238F	981-0518D	981-0604
	KV	E-K	981-0153C	981-0238F	981-0518D	981-0604
	KVC	A-C	981-0158C	981-0238F	981-0518D	981-0620
Camp Power	KVD	A	981-0164B	981-0238F	981-0518D	981-0631B
	KYD	A-B	981-0169	981-0246D	981-0530	981-0636

General Generator Maintenance Intervals								
Model	Service Intervals - Repeat Every							
	Mthly	50 Hrs	100 Hrs	150 Hrs	200 Hrs	250 Hrs	450 Hrs	500 Hrs
CAMP POWER™/MICROLITE™/MICROQUIET™								
Clean & Check Battery & Connections	X (3)							
Clean Arrester		X (5)						
Change Oil				X (1-4)				
Change Air Filter				X (2,4,5)				
Replace Spark Plugs							X (5)	X (5)
Change Fuel Filter								X (5)
Schedule Onan Service Center Tune-Up								X (6)
EMERALD ADVANTAGE™/MARQUIS PLATINUM™/MARQUIS GOLD™								
Clean & Check Battery & Connections	X (3)							
Clean Spark Arrester		X (5)						
Change Oil/Oil Filter				X (1-4)				
Change Air Filter								
Replace Spark Plugs							X (5)	X (2)
Change Fuel Filter							X (5,6)	
Schedule Onan Service Center Tune-Up							X (6)	
EMERALD™/MARQUIS™								
Clean & Check Battery & Connections	X (3)							
Clean Spark Arrester		X (5)						
Change Oil/Oil Filter				X (2-4,7)				
Change Air Filter				X (2,4,5)				
Replace Spark Plugs								X (4,5)
Change Fuel Filter								X (5)
Schedule Onan Service Center Tune-Up								X (6)
DIESEL								
Clean & Check Battery & Connections	X (3)							
Clean Spark Arrester				X (5)				
Change Oil/Oil Filter – All Except Quiet Diesel™		X (1-4)	X (2-4)					
Change Oil/Oil Filter – Quiet Diesel 5500		X (1-4)		X (2-4)				
Change Oil/Oil Filter – Quiet Diesel 7500/8000		X (1-4)		X (2-4)				
Change Oil/Oil Filter – Quiet Diesel 10000/12500		X (1-4)				X (2-4)		
Change Air Filter								X (2,5)
Change Fuel Filter – All Except Quiet Diesel						X (5)		
Change Fuel Filter – Quiet Diesel								X (5)
Schedule Onan Service Center Tune-Up*								X (5,6)

- 1 As a part of engine break-in, change the engine oil after the first 20-50 hours of operation.
- 2 Perform more often when operating in dusty environments.
- 3 Perform more often when operating in hot weather.
- 4 Perform at least once a year.
- 5 Perform sooner if engine performance deteriorates.
- 6 Must be performed by a qualified mechanic (Onan Authorized RV Service and Parts Dealer).
- 7 As a part of engine break-in, change the engine oil after the first 50 hours of operation.

* **Injector check and clean or replace.**

Note: Perform a general inspection and check oil daily per maintenance schedule in Operator's Manual.

DO'S AND DON'TS FOR BETTER GENERATOR PERFORMANCE

The Do's:

- DO keep your generator clean by wiping it periodically with a clean cloth.
- DO turn off all appliances in cold weather before starting your generator, for best long-term performance.
- DO check owners manual for periodic maintenance schedule.
- DO check the exhaust system regularly for damage or leaks. Make sure the exhaust pipe extends out at least one inch beyond the vehicle perimeter.
- DO check the carburetor pre-heating selector (if one is installed) to be sure it's in the proper position for the surrounding climate. (See your Operator's Manual for proper settings.)*
- DO check the air filter periodically and clean it by tapping it on a flat surface. Never wash it in solvents or blow it out with an air hose.
- DO install a running hour meter so you know when scheduled maintenance service is due.
- DO exercise your generator regularly.
- To maintain the LPG fuel filter, purge the fuel system following the procedures listed in the Operator's Manual.
- On diesel models, DO make sure that clean fuel, the most important factor for proper generator performance, is used. Refer to the fuel recommendations covered on page 23.
- DO make sure each operator is familiar with the important safety precautions listed on page 12.
- DO change your fuel filter. The fuel filter is an often forgotten part of any engine. Your generator has one too. It removes bits of debris from the fuel to prevent clogging the carburetor jets. Over time, the fuel filter collects enough material to become plugged, which restricts fuel flow and reduces the generator's power delivery. So be sure to change the fuel filter on a regular maintenance schedule.

The Don'ts:

- DON'T run the generator for long periods of time without using it to power appliances. It wastes fuel and may cause the engine to misfire.
- DON'T attempt to adjust the carburetor, governor, choke, etc., yourself. See your Onan® Authorized RV Service and Parts Dealer for assistance.
- DON'T attempt to adjust EFI components on the Marquis Platinum™.

* **IMPORTANT: Information applies only to carbureted models.**

CAMP POWER™ SERVICE POINT DIAGRAMS

Camp Power 2800

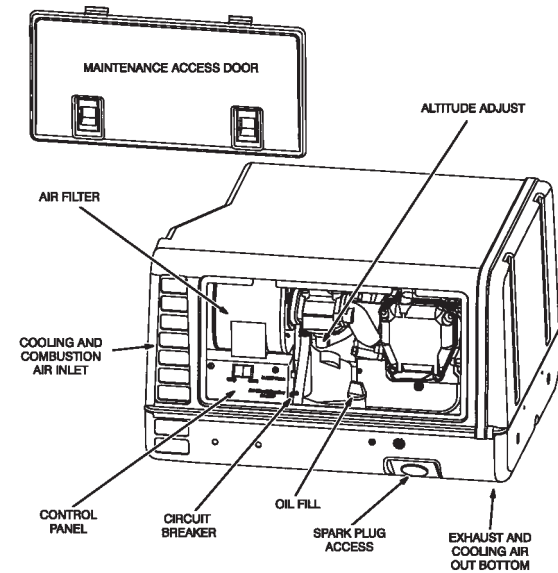

Camp Power 4000

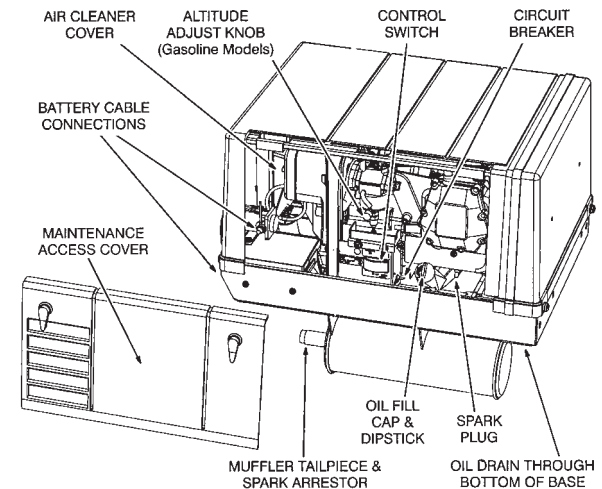

ONAN® SERVICE POINT DIAGRAMS

MicroLite™ 2800

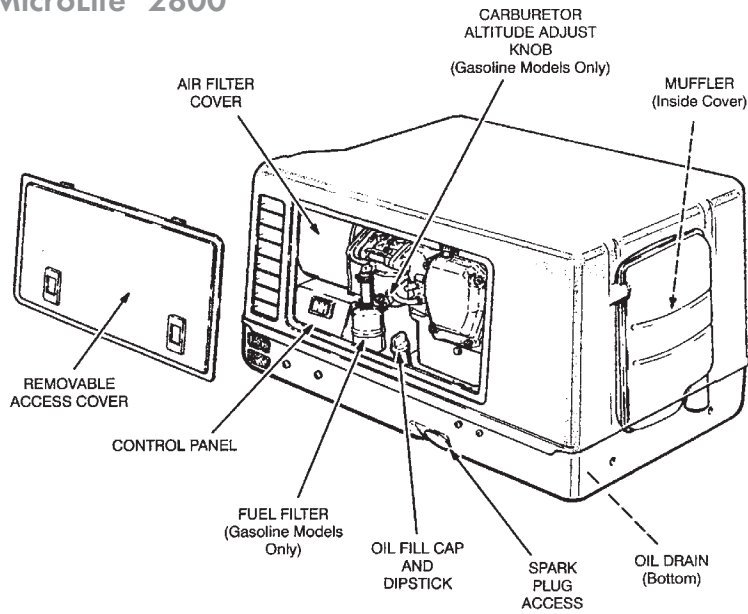

Emerald Advantage™

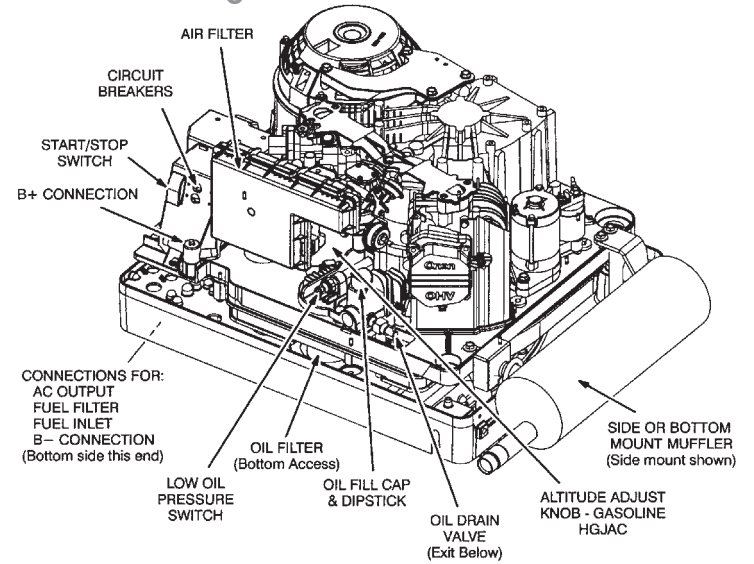

MicroQuiet™ 4000

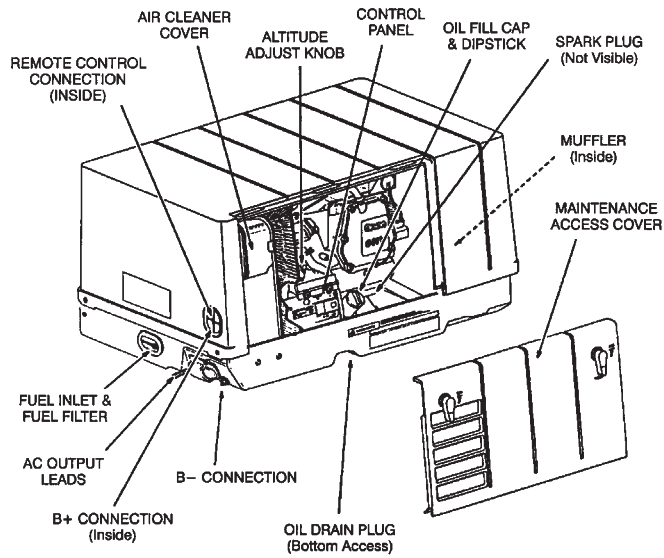

Marquis Gold™/Marquis Platinum™

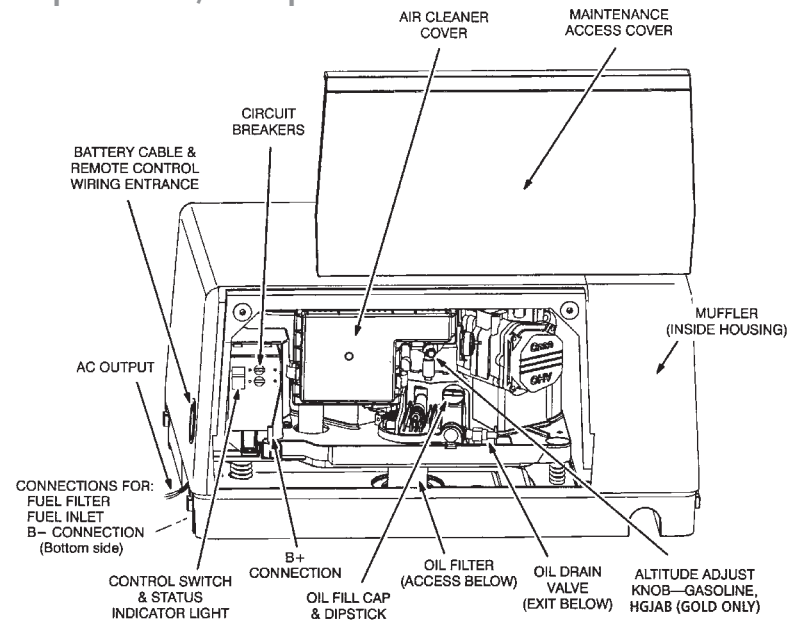

Marquis™

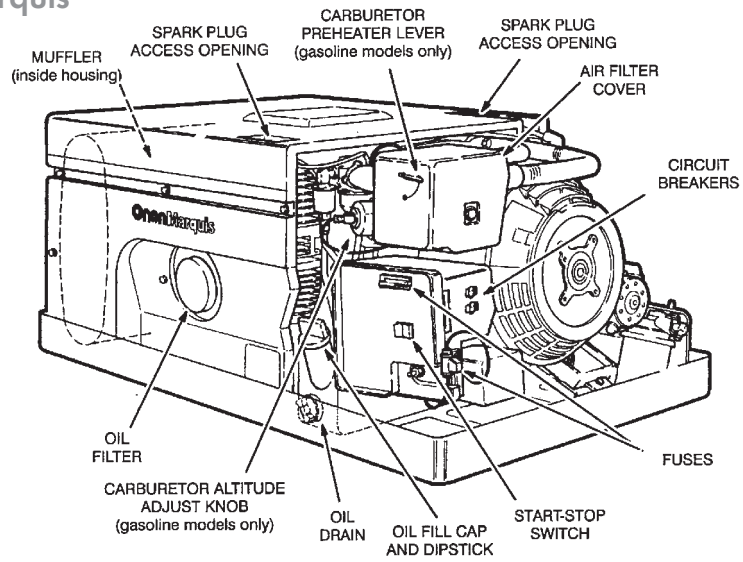

Quiet Diesel™ 5500

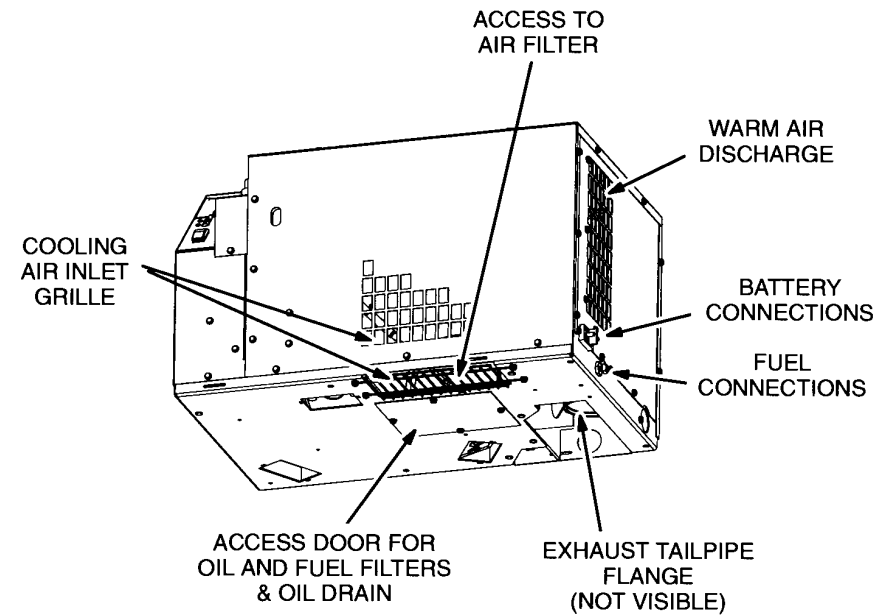
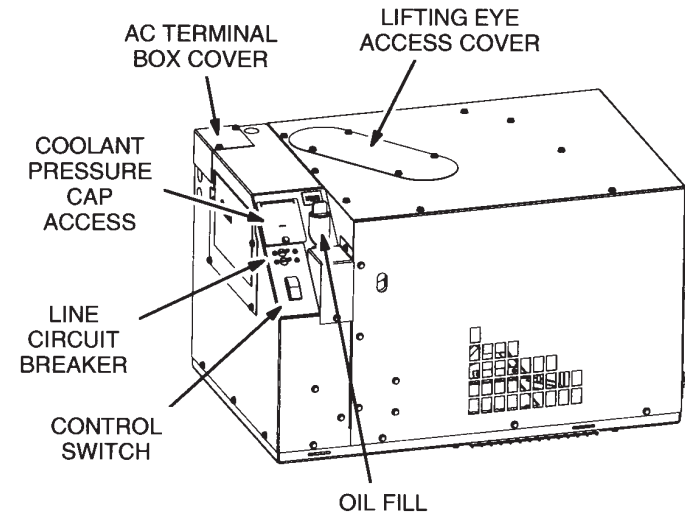

Quiet Diesel™ 7500/8000

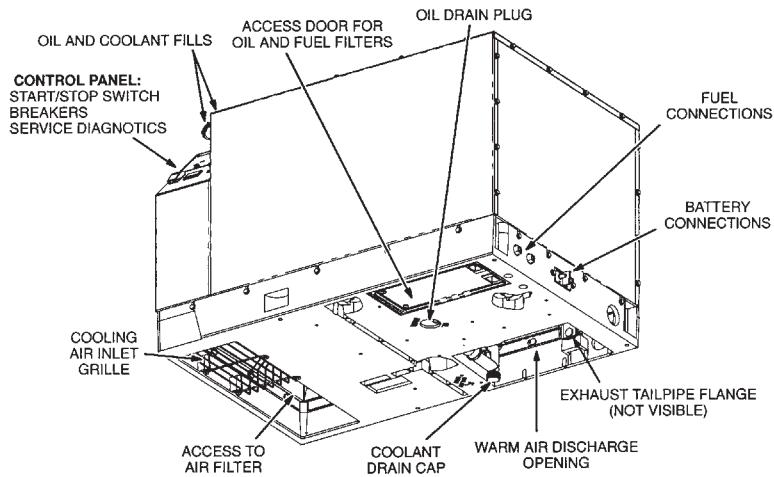

Quiet Diesel 10000/12500

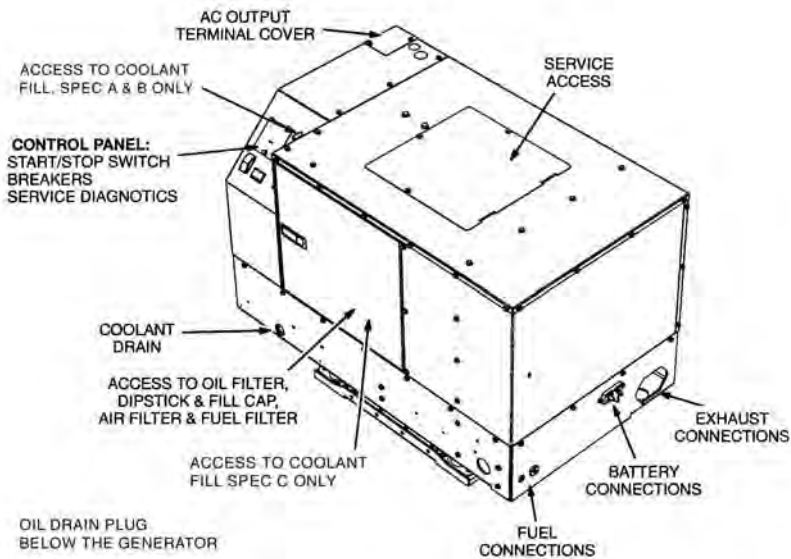

KEEP YOUR GENERATOR CLEAN AND INSPECTED FOR DAMAGE

Your RV generator is a hardworking device that lives in an unfriendly environment, typically in the underside of your RV. Dust and debris are a part of its daily life. Dust can clog the intake system and reduce its engine's efficiency. Remember to replace air and oil filters regularly to remove dust. Over time, vibration from rough roads can loosen generator parts; and debris thrown up from the road can occasionally damage fuel lines and exhaust systems. It makes good sense to inspect all these items regularly. Do not use a water hose or high pressure car wash type sprayers on the generator. Light air pressure is preferred.

FUEL RECOMMENDATIONS

Gasoline Generators – Treat the engine of your Onan® or Camp Power™ generator to a good grade of regular unleaded gasoline and it'll purr in response. Gasohol (gasoline blended with alcohol) can be used if it contains the correct additive mixture percentages:

- Ethanol Blend – Not more than 10% ethanol.
- Methanol Blend – Not more than 5% methanol and must also contain solvents and corrosion inhibitors.

LPG Generators – Use clean, HD-5 grade liquid propane gas in a mixture of at least 90% propane. Propane fuels other than HD-5 can contain more than 2.5 percent butane which can result in poor fuel vaporization and poor engine starting in outside temperatures below 32°F.

Diesel Generators – Use ASTM-2-D (No. 2 Diesel) or ASTM-1-D (No. 1 Diesel) fuel with a minimum Cetane number of 45. No. 2 diesel fuel gives the best economy and performance under most operating conditions. Use No. 1 diesel fuel when ambient temperatures are below 32°F and during long periods of light engine load. Use low sulfur content fuel having a cloud point of at least 10°F below the lowest expected fuel temperature. Cloud point is the temperature at which wax crystals begin to form in diesel fuel.

NOTE: Fill up with fresh gas! The single most common service issue is stale or contaminated fuel. Always use fresh gas! The gas should not be more than 30 days old. Fuel stabilizer extends the life of your fuel. Stale fuel clean-out is not covered under your warranty.

A WORD ABOUT OIL

Use a premium quality engine oil (such as OnaMax™ SAE-30 and SAE 15W-40) in the correct oil viscosity for your generator's typical operating temperature range to provide optimum engine service. Avoid mixing different grades or brands.

It's good practice to check the oil level daily, or every 8 hours of operating time. Keep the oil level as near as possible to full, but do not overfill. Overfilling may cause foaming and engine shutdown. Replace the cap tightly to avoid leakage. And if your generator has an oil filter, change it when you change the oil.

Do NOT check the oil level while the generator is running, because hot oil can be thrown out of the dipstick hole, causing severe burns.

Gasoline Engine Oil Quality – Use oils meeting API performance categories SH/CE, SH/CD, SH, SJ, SJ/CE or SJ/CD.

Diesel Engine Oil Quality – Use oils meeting API performance categories CG-4, CF-4, CE/SG or CD/SG.

Oil Viscosities – Use the following information to select correct viscosity grades for expected ambient temperature range.

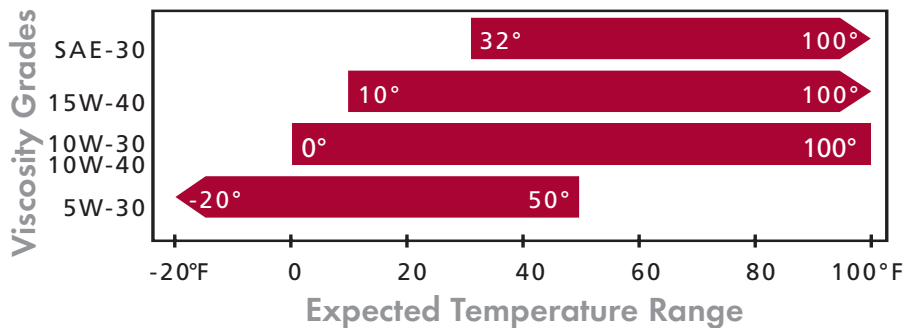

NOTE: Multi-grade oils (such as SAE 15W-40) are recommended for year-round use in Onan® liquid-cooled engines, or as a good all-season oil for air-cooled engines.

NOTE: SAE-30 is the preferred summer grade for optimum oil consumption control in Onan air-cooled engines.

PREVENT FUEL VARNISHING

If You Don't Run A Tank Of Gas A Month, You Could Be Risking The Performance Of Your RV Generator.

If you store your RV over the winter, or don't operate it often enough to refuel the gas tank every month, you could develop a fuel varnishing problem in your engine – particularly in your generator.

Fuel varnishing is a gummy residue that clogs the generator carburetor and fuel pump. It's caused by the deterioration of fuel that sits in the engine too long, and it happens in a surprisingly short period of time. Depending on fuel quality and storage conditions, gasoline can deteriorate in as little as 30 days. As long as you refuel frequently with fresh gasoline, and exercise the unit regularly, fuel varnishing is less likely to occur. But if you leave the same gasoline in the tank for several months, you're very likely to have problems.

Fuel varnishing affects many engines, but it's more noticeable in generators because the engines are smaller. Even the slightest decrease in efficiency has a big impact on performance. A generator with varnish buildup may start, but runs like it needs a tune-up. It surges, accelerating and decelerating, but never settling on a stable operating speed.

In many of the gasoline powered units, engine speed directly affects generator voltage output and frequency. As speed increases/decreases, so does the voltage and frequency.

The only ways to prevent fuel varnishing are to treat the contents of the tank supplying fuel to the generator with a fuel preservative and to exercise the set. Onan has developed a fuel preservative and stabilizer, OnaFresh™, specifically formulated for Onan and Camp Power™ generators. We recommend adding this preservative to the fuel, especially on infrequently used RVs.

Emptying the tank won't prevent fuel varnishing because a small amount of fuel always remains in the generator carburetor. If you plan to leave the tank empty, we recommend that you add a special mixture of fuel and a preservative before you run the tank dry so the residual fuel contains the preservative.

Once varnishing has occurred, adding a preservative won't correct the problem. You need to add a fuel cleaner, or manually scrape the varnish from the fuel system parts. Onan offers Premium Fuel System Cleaner for use with Onan and Camp Power generators.

By understanding how to properly care for your RV generator and protect against fuel varnishing, you'll enjoy better performance and longer, service-free operation. It may seem strange that "not" using a product causes it to break down faster. With generators, though, that's exactly the case.

Premium Fuel System Cleaner and OnaFresh, along with other Green Label Parts™ maintenance products can be found at your local Onan Authorized RV Service and Parts Dealer. To locate your nearest dealer, visit Funroads.com.

IMPORTANT: Problems caused by fuel varnishing will not be covered under warranty.

TROUBLESHOOTING GUIDE

Under normal operating conditions, you can expect your Onan® or Camp Power™ generator to perform reliably without any problems. But if a problem does occur you may be able to isolate the cause by using the following troubleshooting chart.

If you cannot discover and correct the problem, make a note of your generator model and serial numbers and contact your local Onan Authorized RV Service and Parts Dealer. Quiet Diesel™ generators have a unique control system. Consult your Quiet Diesel Owner's Manual for troubleshooting information.

Trouble Shooting Guide		
Problem	Probable Cause	Solution
FAILS TO CRANK	<ol style="list-style-type: none"> 1. Low battery. 2. Bad battery connection. 3. Blown fuse. 	<ol style="list-style-type: none"> 1. Check battery fluid level. 2. Clean & tighten all battery & cable connections. 3. Replace fuse on control panel.
CRANKS SLOWLY	<ol style="list-style-type: none"> 1. Low battery. 2. Bad battery connection. 3. Incorrect oil viscosity. 4. Load connected. 	<ol style="list-style-type: none"> 1. Check battery fluid level. 2. Clean & tighten all battery & cable connections. 3. Replace with recommended viscosity oil. 4. Disconnect load before starting.
CRANKS BUT WON'T START	<ol style="list-style-type: none"> 1. Fuel below generator pickup level in tank. 2. Fuel supply shutoff valve closed. 3. Carbon deposits on spark plug(s). 4. Low oil level. 	<ol style="list-style-type: none"> 1. Add fuel. 2. Fully open fuel supply valve. 3. Remove spark plug(s) and replace. 4. Add oil.
EXHAUSTING BLACK SMOKE	<ol style="list-style-type: none"> 1. Dirty air filter. 2. Choke stuck or misadjusted. 	<ol style="list-style-type: none"> 1. Replace air filter. 2. Contact an Onan Authorized RV Service & Parts Dealer.
UNIT RUNS THEN STOPS, OR STOPS WHEN DRIVING AROUND A CORNER	<ol style="list-style-type: none"> 1. Low fuel level. 2. Low oil level. 3. Excess oil. 	<ol style="list-style-type: none"> 1. Add fuel. 2. Add oil. 3. Reduce engine oil level.
UNIT STARTS AND RUNS, THEN STOPS WHEN THE START SWITCH IS RELEASED	<ol style="list-style-type: none"> 1. Low fluid levels. 2. Possible overheating. 3. Other functional problem. 4. No AC output. 	<ol style="list-style-type: none"> 1. Check & bring all fluids up to the appropriate levels. 2. Check for blocked air flow or other possible causes of overheating. 3. Contact an Onan Authorized RV Service & Parts Dealer. 4. Contact an Onan Authorized RV Service & Parts Dealer.
UNIT RUNS THEN SURGES	<ol style="list-style-type: none"> 1. Loose or worn spark plug leads. 2. Defective ignition coil, wiring, or control components. 3. Faulty spark plug. 4. Governor out of adjustment. 5. Combustion air pre-heat malfunction. 6. Carburetor icing. 7. Carburetor varnishing. 	<ol style="list-style-type: none"> 1. Check spark plug leads at spark plug & ignition coil. 2. Contact an Onan Authorized RV Service & Parts Dealer. 3. Remove spark plug & clean or replace. 4. Contact an Onan Authorized RV Service & Parts Dealer. 5. Contact an Onan Authorized RV Service & Parts Dealer. 6. Move carburetor pre-heater to the winter position. 7. Try fuel system cleaner and contact dealer if no change.
CIRCUIT BREAKER TRIPS	<ol style="list-style-type: none"> 1. Overloaded circuit. 	<ol style="list-style-type: none"> 1. Turn-off some of the electrical load, and reset the circuit breaker.

WARNING! Incorrect troubleshooting procedures can result in risks of property damage, or death from fire, explosion, electrocution, and asphyxiation or being caught or hit by moving parts. DO NOT ATTEMPT TROUBLESHOOTING unless you are trained and experienced in electrical and mechanical maintenance.



IV: GENERATOR MAINTENANCE: PARTS AND CHEMICALS

INSIST ON THE QUALITY OF GREEN LABEL PARTS™

Insist on Green Label Parts. Genuine Onan. These replacement and maintenance products have been specially designed by Onan for RV generator use to provide you with dependable power and performance for the life of your generator. They are available from all Onan Authorized RV Service and Parts Dealers. Maintenance parts can also be ordered online at Funroads.com. See pages 30-33 for part numbers by set.

Air Filters

Green Label Parts air filters are designed with a special foam pre-cleaner, for use specifically in RV generators. Other manufacturers' air filters may contain a lighter density filter paper and the sealing surfaces may get hard and crack over time, allowing dirty air into the engine intake system. Over time, it only takes about a thimbleful of dirt to wear out piston rings and cylinders. (Replacement filters for some older models may not include the pre-cleaner.)

Spark Plugs

Green Label Parts™ spark plugs come gapped correctly from the factory for your RV generator engine. Spark plugs purchased from other sources come gapped for automotive engines, which are gapped much larger. When regapping, the ground strap must be bent and it may not cover all of the electrode, which will reduce spark plug life.

Oil Filters

Green Label Parts oil filters feature valves that allow oil to bypass the oil filter during cold starts, or if the filter becomes plugged. Other manufacturers' oil filters often do not have bypass valves. As these "will-fit" filters trap debris, oil pressure starvation can occur, leading to high oil pressures, failed gaskets and even engine damage. Other "will-fit" oil filters do contain bypass valves but they do not determine at what PSI the valve opens. If the setting is too high, the filter's paper element can be damaged during a cold start rendering it useless, or cause oil starvation to the engine.

Tune-Up Kits

Green Label Parts spark plugs, points and condenser for Emerald™, Microlite™ and many older-model Onan® RV generator tune-ups.

Cable Pack Kit

Two high-tension plug wire leads and boots for Emerald, Marquis™, Microlite and many older-model Onan RV generators. Designed to keep RFI (Radio & TV Interference) at a minimum for optimum appliance performance.

Fuse Pack Kit

Pack of five fuses for use in most Onan and Camp Power RV generators.

Oil Filter Wrench

Cup-type oil filter wrench for easy removal of RV generator oil filters. Onan Emerald Advantage™, Marquis Gold™ and Marquis Platinum™ Part #420-0577

IMPORTANT: Onan warrants only the quality and integrity of Green Label Parts. Any damage caused by the use of non-Green Label Parts filters will not be covered under the Onan limited warranty.



USE ONAN OIL AND SERVICE/MAINTENANCE CHEMICALS TO INSURE PERFORMANCE

OnaMax™ 15W-40 Oil And SAE-30

Factory recommended and tested, maximum protection engine oil formulated to reduce consumption and engine wear due to high temperature oil oxidation and viscosity increase. One-quart bottle.

SAE-30 #326-5339
15W-40 #326-5336

OnaFresh™ GxLP Fuel Stabilizer

A premium fuel additive, specially formulated for long-lasting prevention of gasoline breakdown during extended RV

storage. Protects gasoline against gum, varnish and sludge formation as well as fuel system corrosion. 16-oz. bottle treats 40 gallons of gasoline. #326-5365

Onagard™ Storage Fogging Spray

Protects small engines and other mechanical equipment during off-season storage. Provides protection for up to six months. 12-oz. aerosol can. #326-5288

Onan Premium Fuel System Cleaner

Promotes smoother, more efficient gasoline engine operation. Cleans dirty carburetors and fuel injection systems; removes fuel system gum and varnish; reduces valve and intake deposits. 12-oz. bottle treats up to 24 gallons of gasoline. #326-5342

4C Combustion Chamber And Carburetor Cleaner

Removes power-robbing buildup of carbon, gum and varnish. Regular use can extend intervals between combustion chamber carbon maintenance cleanings. 12-oz. aerosol can provides carbon removal for one generator. #326-5278

When reliability counts, insist on Green Label Parts™ Genuine Onan®

Brand Name Model/Series	Spec Letter	Tune-up Kit	Oil Filter	Air Filter	Fuel Filter	Glow Plug or Spark Plug	Plug Wire
Camp Power™							
KVD	A-B	Electronic Ignition	—	140-2105	149-2137	167-0263-02	—
KYD 50 Hz	A-B	Electronic Ignition	—	140-3280	149-2457	167-0305	—
KYD 60 Hz						167-0275	
Emerald Advantage™							
Gasoline/HGJAC	A-C	Electronic Ignition	122-0836	140-3116	149-2629	167-1638	—
LP Vapor/HGJAC					149-2648		
Emerald™							
BGE	A-E	160-1378	122-0645	140-2379	—	167-0272	9" 167-1615-01 26" 167-1602
Prior to 9/87 NHEL	F	160-1378	122-0645	140-2379	149-2279	167-0272	9" 167-1615-01 26" 167-1602
Begin 9/87 NHEL		160-1349-01					
BGE	G	Electronic Ignition	122-0645	140-2379	149-2279	167-0272	9" 167-1615-01 26" 167-1602
BGE	H	Electronic Ignition	122-0645	140-2379	149-1353	167-0272	9" 167-1615-01 26" 167-1602
BGE	J-P	Electronic Ignition	122-0645	140-2379	149-2333	167-0272	9" 167-1615-01 26" 167-1602
BGEL	A-E	160-1378	122-0645	140-2379	148-0898	167-0272	9" 167-1615-01 26" 167-1602
NHE	A-E	160-1378	122-0800	140-2379	—	167-0272	9" 167-1615-01 26" 167-1602

Brand Name Model/Series	Spec Letter	Tune-up Kit	Oil Filter	Air Filter	Fuel Filter	Glow Plug or Spark Plug	Plug Wire
Emerald (continued)							
Prior to 9/87 NHE	F	160-1378	122-0800	140-2379	149-2279	167-0272	9" 167-1615-01 26" 167-1602
Begin 9/87 NHE		160-1349-01					
NHE	G	Electronic Ignition	122-0800	140-2379	149-2279	167-0272	9" 167-1615-01 26" 167-1602
NHE	H	Electronic Ignition	122-0800	140-2379	149-1353	167-0272	9" 167-1615-01 26" 167-1602
NHE	J-P	Electronic Ignition	122-0800	140-2379	149-2333	167-0272	9" 167-1615-01 26" 167-1602
NHEL	A-E	160-1378	122-0800	140-2379	148-0898	167-0272	9" 167-1615-01 26" 167-1602
Marquis™							
Gasoline/BGM	A-F	Electronic Ignition	122-0645	140-2379	149-2279	167-0272	9" 167-1625-01 23" 167-1625-02
Gasoline/BGM	G-H				149-2341		
Gasoline/NHM	A-F	Electronic Ignition	122-0800	140-2379	149-2279	167-0272	167-1602
Gasoline/NHM	G-H	Electronic Ignition	122-0800	140-2379	149-2341	167-0272	167-1602
LP/NHM	All	Electronic Ignition	122-0800	140-2379	148-0898	167-0272	167-1602
Marquis Gold™							
Gasoline/HGJAB	A	Electronic Ignition	122-0836	140-3116	149-2629	167-1638	—
LP/HGJAB					149-2648		
Marquis Platinum™							
EFI/HGJAA	A	Electronic Ignition	122-0836	140-3116	147-0860	167-1638	—
LP/HGJAA					149-2648		

Brand Name Model/Series	Spec Letter	Tune-up Kit	Oil Filter	Air Filter	Fuel Filter	Glow Plug or Spark Plug	Plug Wire
MicroLite™							
KV	A-K	Electronic Ignition	—	140-2105	149-2137	167-0263-02	—
KVC	A-C			140-2609	149-2457	167-0305	—
KY	A	Electronic Ignition	—	140-3295	149-2457	167-0305	—
KY 50 Hz	B-L			140-2609	149-2457	167-0275	—
KY 60 Hz	B-L			140-3295	149-2457	167-0275	—
MicroQuiet™							
KY 50 Hz	J-L	Electronic Ignition	—	140-3280	149-2457	167-0305	Brand N
KY 60 Hz	J-L	Electronic Ignition	—	140-3295	149-2457	167-0275	
Quiet Diesel™							
HDCAA	A-C	—	187-1000	140-3071	149-2513	187-1289	—
HDCAB	A-C	—	187-1000	140-3071	149-2513	187-1289	—
HDKAJ	A-H	—	122-0833	140-2897	149-2513	185-5421	—
HDKAK	A-H	—	122-0833	140-2897	149-2513	185-5421	—
HDKBA	A	—	185-7444	140-3351	149-2513	185-5421	—
HDKCA	A	—	122-0810	140-3071	149-2513	185-5990	—
HDKCB	A	—	122-0810	140-3071	149-2513	185-5990	—
Older Onan® Generators							
BF Power Drawer	A	160-1154, 312-0069	122-0645	140-1220	—	167-0262	167-1616-01
BF RV	A-B	160-1328-01	—	—	—	167-0237	—
BFA RV	A	160-1328-01	122-0645	140-0495	—	167-0237	167-1616-01
BFA RV	B-D	160-1348-01	122-0645	140-0495	—	167-0298	—
BGA RV	A	160-1328-01	122-0645	140-0495	—	167-0237	167-1616-01
BGA RV	B-D	160-1348-01	122-0645	140-0495	—	167-0298	—

Brand Name Model/Series	Spec Letter	Tune-up Kit	Oil Filter	Air Filter	Fuel Filter	Glow Plug or Spark Plug	Plug Wire
Older Onan Generators (continued)							
BGAL RV	C	160-1348-01	122-0645	140-0495	—	167-0298	167-1616-01
CCK Mobile/RV	A-Q	160-0002	122-0800	—	—	167-0237	167-1602
CCK Mobile/RV	R-U	312-0069	122-0800	140-0495	—	167-0237	—
LK RV	A-L M	160-0002, 312-0069	—	—	149-1353	167-0237	—
NH Power Drawer	A	160-1154, 312-0069	122-0800	140-1229	—	167-0262	167-1616-01
NH Power Drawer 9000	A-H	160-1154, 312-0069	122-0800	140-1229	—	167-0262	167-1616-01
NH RV	A-H	160-0002, 312-0069	122-0800	140-0495	—	167-0241	167-1616-01
NH RV	J-N	160-1328-01	122-0800	140-0495	—	167-0247	—
NH RV	P-R	160-1378	122-0800	140-0495	—	167-0272	—
NHL	P	160-1328-01	122-0800	140-0495	—	167-0272	9" 167-1615-01 26" 167-1602
Older Onan Diesel Generators							
HDKAG	A-B	—	185-5835	140-2842	149-2106	185-6623	—
HDKAG	C	—	185-5835	140-2842	149-2106	185-5421	—
HDKAG	D-E	—	185-5835	140-2842	149-2106	185-5421	—
DKC RV	A	—	122-0827	140-2842	149-1914-05	185-2289	—
DKC RV	B	—	122-0827	140-2842	149-2106	185-2289	—
DKD RV	A-B	—	122-0827	140-2842	149-1914-05	185-2289	—
DKD RV	C-E	—	122-0827	140-2842	149-2106	185-2289	—
DKG	A	—	122-0827	140-2680	149-2106	185-2289	—

*Ask your Onan Authorized RV Service and Parts Dealer to assist you in identifying the correct maintenance parts for these models.



V: WARRANTY AND SERVICE

STANDARD 3-YEAR LIMITED WARRANTY WITH AVAILABLE 5-YEAR EXTENDED COVERAGE

We're so confident in our RV generators, we back them with a standard 3-year limited warranty — the longest, most comprehensive warranty in the business. And for an additional charge, full coverage can be extended to five years, through the Onan®/Camp Power™ Care Extended Warranty. Whichever you choose, coverage is transferable from one owner to another if you sell your RV during the generator warranty period. See your Onan Authorized RV Service and Parts Dealer for details.

LARGEST AUTHORIZED SERVICE AND PARTS DEALER NETWORK IN THE INDUSTRY

Wherever you travel, Onan Authorized RV Service and Parts Dealers are never far away. Authorized Dealers trained and tested in all aspects of generator operation and maintenance cover every major market in the United States and Canada. Onan's extensive training and certification process demonstrates our strong commitment to exceptional product service and support. For a free list of Onan Authorized RV Service Dealers in the United States and Canada, call 1-800-888-ONAN and request publication #F-919 or find your closest dealer on Funroads.com.

COACH CARE™ SERVICE CENTERS GIVE YOU ONE STOP SERVICE AND REPAIR FOR YOUR RV. BUMPER TO BUMPER. COAST TO COAST.

Coach Care Service Centers are the only nationwide bumper-to-bumper service network exclusively for motor homes. For chassis work, maintenance, appliance repairs and everything in between, Coach Care provides professional service in a friendly, no-hassle atmosphere. And because we have over 30 integrally linked Coach Care locations, our work is guaranteed everywhere you travel.

Benefits Of Coach Care.

- Conveniently located across the United States
- All Coach Care service centers have a reciprocal warranty
- Expert repair from the chassis, to the main drive engine, to your Onan® or Camp Power™ generator
- State-of-the-art equipment to aid in quick and thorough service
- 24-hour emergency service, 7 days a week

Amenities To Make Your Visit Comfortable And Convenient.

- Complimentary overnight parking with electrical hook-up
- LP Stations*
- Sanitation and sewage disposal*

*Not available at all facilities.

One Stop Service.

- Coach Care technicians provide authorized service on everything from your engine to your appliances.



COACH CARE LOCATIONS

COMPLETE LISTINGS ON P. 38-39

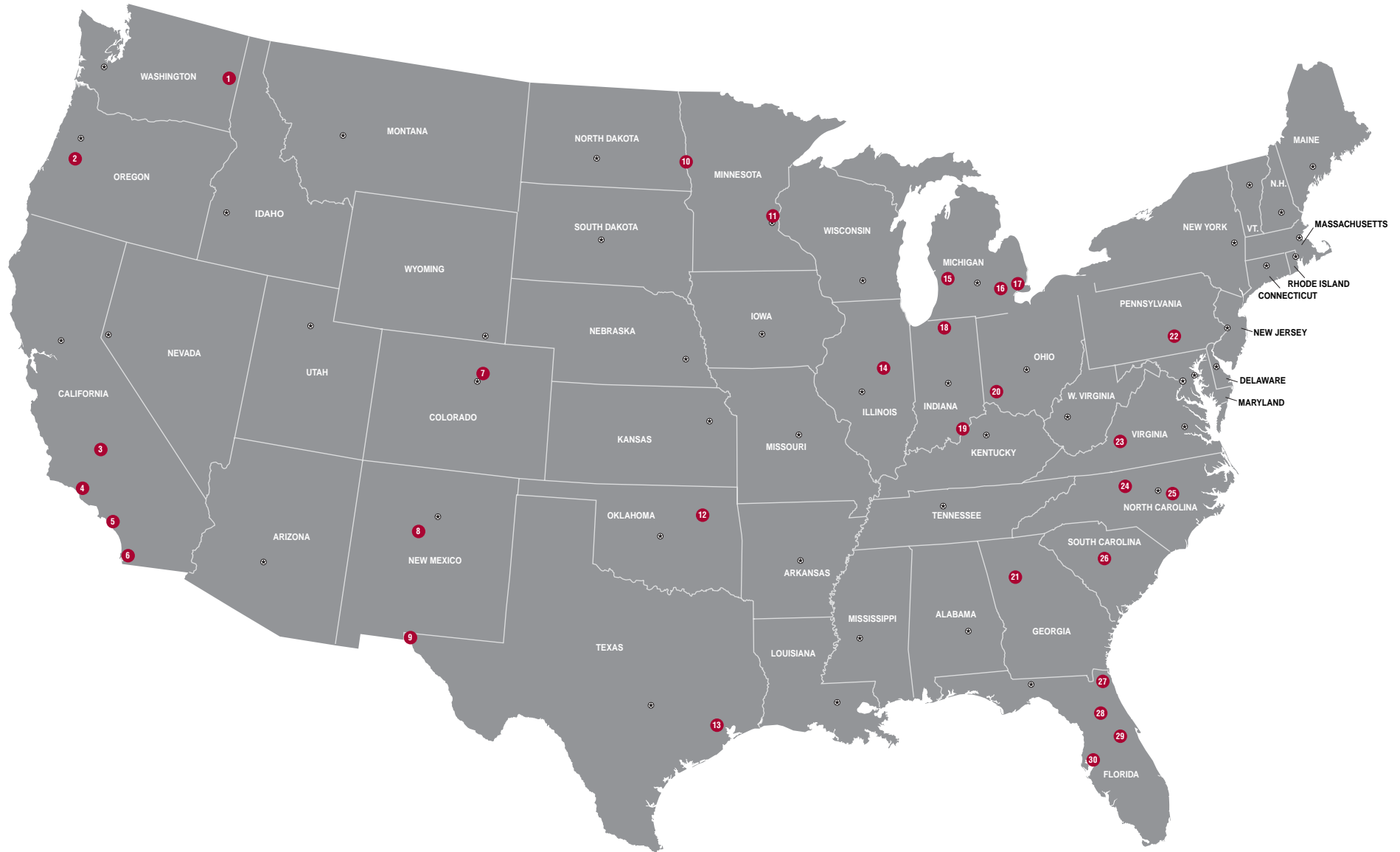



California

3. Cummins West

4601 East Brundage Lane
Bakersfield, CA 93307
Phone: 661-325-9404

4. Cummins Cal Pacific

3958 Transport St.
Ventura, CA 93003
Toll free: 800-881-1159

5. Cummins Cal Pacific

1939 Deere Avenue
Irvine, CA 92606
Toll free: 800-222-4871

6. Cummins Cal Pacific

485 Raleigh Avenue
El Cajon, CA 92020
Toll free: 800-993-4373

Colorado

7. Cummins Rocky Mountain

8211 E 96th Ave.
Henderson, CO 80640
Toll free: 800-927-7201

Florida

27. Cummins Southeastern Power

755 Picketville Road
Jacksonville, FL 32220
Toll free: 800-338-7027

28. Cummins Southeastern Power

321 S.W. 52nd Avenue
Ocala, FL 34474
Toll free: 888-699-2774

29. Cummins Southeastern Power

4820 N. Orange Blossom Trail
Orlando, FL 32810
Toll free: 800-338-7039

30. Cummins Southeastern Power

5910 E. Hillsborough Ave.
Tampa, FL 33610
Toll free: 800-338-2519

Georgia

21. Cummins South

5125 Highway 85
Atlanta, GA 30349
Toll free: 800-768-7278

Illinois

14. Cummins Mid-States Power

450 W. Northtown Rd.
Normal, IL 61761
Toll Free: 800-759-4355

Indiana

19. Cummins Cumberland

520 Marriott Dr.
Clarksville, IN 47129
Toll free: 800-583-5685

18. Onan Indiana

5125 Beck Drive
Elkhart, IN 46516
Toll free: 800-589-9027

Michigan

15. Cummins Bridgeway

7580 Expressway Drive S.W.
Grand Rapids, MI 49548
Phone: 616-281-2211

16. Cummins Bridgeway

54250 Grand River Ave.
New Hudson, MI 48165
Toll free: 800-486-4308

17. Cummins Bridgeway

43575 North Gratiot Avenue
Clinton Township, MI 48036
Phone: 586-469-2010

Minnesota

11. Cummins NPower

1600 Buerkle Road
White Bear Lake, MN 55110
Toll free: 800-642-0085

New Mexico

8. Cummins Rocky Mountain

1921 Broadway N.E.
Albuquerque, NM 87102
Toll free: 800-800-3888

North Carolina

24. Cummins Atlantic

513 Preddy Blvd.
Greensboro, NC 27406
Phone: 336-275-4531

25. Cummins Atlantic

350 Cummins Dr.
Kenly, NC 27542
Toll free: 888-288-7181

North Dakota

10. Cummins NPower

3801 34th Avenue S.W.
Fargo, ND 58104
Toll free: 800-373-2466

Ohio

20. Cummins Bridgeway

5400 Rialto Rd.
West Chester, OH 45069
Toll free: 877-678-7744

Oklahoma

12. Cummins Southern Plains

16525 East Skelly Drive
Tulsa, OK 74116
Toll free: 800-722-2743

Oregon

2. Cummins Northwest

91201 Coburg Industrial Parkway
Coburg, OR 97408
Toll free: 866-236-2167

Pennsylvania

22. Cummins Power Systems

4499 Lewis Rd.
Harrisburg, PA 17111
Toll free: 800-841-1344

South Carolina

26. Cummins Atlantic

2791 Shop Road Extension
Columbia, SC 29209
Toll free: 800-695-5383

Texas

9. Cummins Rocky Mountain

14333 Gateway West
El Paso, TX 79928
Toll free: 800-800-4240

13. Cummins Southern Plains

7045 N. Loop East
Houston, TX 77028
Toll free: 800-474-7421

Virginia

23. Cummins Atlantic

263 Simmons Dr.
Cloverdale, VA 24077
Toll free: 800-280-4582

Washington

1. Cummins Northwest

11134 W. Westbow Blvd.
Spokane, WA 99224
Toll free: 800-825-2122



VI: CAMP POWER™ AND ONAN® RV GENERATOR MODELS

CAMP POWER 2800



CAMP POWER 4000



THE FIRST INSTALLED GENERATORS FOR TRAVEL TRAILERS, TRUCK CAMPERS AND FOLDING CAMPING TRAILERS.

Camp Power 2800 and 2500 LP

- Runs one 13500 BTU air conditioner with power to spare.
- Lightweight, compact design that's easy to install.
- Fully-enclosed design for reduced noise.
- Front access panel for easy service and maintenance.
- Gasoline or LP-fueled.

Camp Power 4000 and 3600 LP

Includes all the features and benefits above, PLUS...

- Microprocessor control with diagnostics for easy troubleshooting.

Camp Power Specifications						
Model	2800	2500 LP		4000	3600 LP	
Watts	2800	2500		4000	3600	
RPM	3600	3600		3600	3600	
Volts	120	120		120	120	
Hertz	60	60		60	60	
Amps	23.3	20.8		33.3	30.0	
Weight (lb)	107	107		167	167	
Avg. Fuel Consumption	(gal/hr)	(gal/hr) (lb/hr)		(gal/hr)	(gal/hr) (lb/hr)	
No Load	0.2	0.2	0.9	0.3	0.4	1.7
Half Load	0.3	0.3	1.3	0.5	0.6	2.6
Full Load	0.4	0.5	2.1	0.7	0.7	3.0
Sound Level dB(A)						
Half Load*	71	71		70	70	
Engine Horsepower	7	7		9.5	8.6	

*Typical RV installation. All readings at 10 ft. (3m).

Dimensions: (L x W x H in inches)

2800 & 2500 LP: 19.6 x 16.7 x 12.3

4000 & 3600 LP: 25.7 x 19.7 x 14.4

Engine Detail:

4-cycle, single cylinder, overhead valve.

Power Capabilities: (at 100°F and 500' feet altitude)

- Camp Power 2800: Starts one 13500 BTU air conditioner with approved start circuit, plus 600-watt baseload. Or, one 11000 BTU air conditioner with approved start circuit, plus 1000-watt baseload.
- Camp Power 2500 LP: Starts one 13500 BTU air conditioner with approved start circuit, plus 300-watt baseload. Or, one 11000 BTU air conditioner with approved start circuit, plus 600-watt baseload.
- Camp Power 4000: Starts one 13500 BTU air conditioner, plus 2000-watt baseload.
- Camp Power 3600 LP: Starts one 13500 BTU air conditioner, plus 1600-watt baseload.

MICROLITE™ 2800



MICROQUIET™ 4000



LIGHTWEIGHT, COMPACT AND QUIET GASOLINE/LP RV GENERATORS

MicroLite

- Runs one 13500 BTU air conditioner with power to spare and easy-start motor circuit.
- Lightweight and compact.
- Single-side service for easy maintenance.
- Fully-enclosed muffler.
- Gasoline or LP-fueled.

MicroQuiet

Includes all the features and benefits above, PLUS...

- Microprocessor control with diagnostics for easy troubleshooting.

MicroLite and MicroQuiet Specifications

Model	2800	2500 LP	4000	3600 LP
Watts	2800	2500	4000	3600
RPM	3600	3600	3600	3600
Volts	120	120	120	120
Hertz	60	60	60	60
Amps	23.0	20.8	33.3	30.0
Weight (lb)	113	113	172	172
Avg. Fuel Consumption	(gal/hr)	(gal/hr) (lb/hr)	(gal/hr)	(gal/hr) (lb/hr)
No Load	0.2	0.2 0.9	0.3	0.4 1.7
Half Load	0.3	0.3 1.3	0.5	0.6 2.6
Full Load	0.4	0.5 2.1	0.7	0.7 3.0
Sound Level dB(A)				
Half Load*	70	70	66	66
Engine Horsepower	7	7	9.5	8.6

*Typical RV installation. All readings at 10 ft. (3m).

Dimensions: (L x W x H in inches)

2800 & 2500 LP: 24.0 x 16.4 x 12.3

4000 & 3600 LP: 30.0 x 19.7 x 14.4

Engine Detail:

4-cycle, single cylinder, overhead valve.

Power Capabilities: (at 100°F and 500' altitude)

- MicroLite 2800: Starts one 13500 BTU air conditioner with approved start circuit, plus 600-watt baseload. Or, one 11000 BTU air conditioner with approved start circuit, plus 1000-watt baseload.
- MicroLite 2500 LP: Starts one 13500 BTU air conditioner with approved start circuit, plus 300-watt baseload. Or, one 11000 BTU air conditioner with approved start circuit, plus 600-watt baseload.
- MicroQuiet 4000: Starts one 13500 BTU air conditioner, plus 2000-watt baseload.
- MicroQuiet 3600 LP: Starts one 13500 BTU air conditioner, plus 1600-watt baseload.

EMERALD ADVANTAGE™ 5500

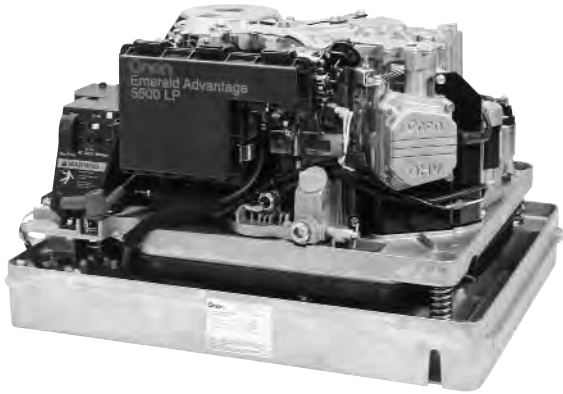

EMERALD ADVANTAGE 7000



Emerald Advantage

- Runs one or two 13500 BTU air conditioners with power to spare.
- Self-diagnostic capability to simplify troubleshooting.
- Digital voltage regulation for stability as appliance loads change.
- Gasoline or LP-fueled.

Emerald Advantage Specifications

Model	5500	5500 LP	7000	6500 LP
Watts	5500	5500	7000	6500
RPM	2400	2400	2800	2800
Volts	120	120	120	120
Hertz	60	60	60	60
Amps	45.8	45.8	58.3	54.2
Weight (lb)	228	228	239	239
Avg. Fuel Consumption	(gal/hr)	(gal/hr) (lb/hr)	(gal/hr)	(gal/hr) (lb/hr)
No Load	0.3	0.4 1.7	0.4	0.5 2.1
Half Load	0.6	0.8 3.4	0.7	0.8 3.4
Full Load	0.9	1.1 4.7	1.2	1.2 5.1
Sound Level dB(A)				
Half Load*	74	74	74	74
Engine Horsepower	12.9	14.0	10.7	11.6

***Typical RV installation. All readings at 10 ft. (3m).**

Dimensions: (L x W x H in inches)

All Models: 26.9 x 21.8 x 16.0

Engine Detail:

4-cycle, OHV, 90-degree V-Twin.

Power Capabilities: (at 100°F and 500' altitude)

- Emerald Advantage 5500/5500 LP: Starts one 13500 BTU air conditioner with 3300-watt baseload. Or, two 13500 BTU air conditioners with 1300-watt baseload.
- Emerald Advantage 7000/6500 LP: Starts two 13500 BTU air conditioners with 3000-watt baseload.

MARQUIS GOLD™ 5500



MARQUIS GOLD 7000



Marquis Gold

- Runs one or two 13500 BTU air conditioners with power to spare.
- Fully integrated design makes it the quietest in its class.
 - Enclosed muffler
 - Low vibration levels
 - Self-diagnostic capability to simplify troubleshooting
 - Digital voltage regulation for stability as appliance loads change
- Gasoline or LP-fueled.

Marquis Gold Specifications

Model	5500	5500 LP	7000	6500 LP
Watts	5500	5500	7000	6500
RPM	2400	2400	2880	2880
Volts	120	120	120	120
Hertz	60	60	60	60
Amps	45.8	45.8	58.3	54.2
Weight (lb)	279	279	290	290
Avg. Fuel Consumption	(gal/hr)	(gal/hr) (lb/hr)	(gal/hr)	(gal/hr) (lb/hr)
No Load	0.3	0.4 1.7	0.4	0.4 1.7
Half Load	0.6	0.8 3.4	0.7	0.8 3.4
Full Load	0.9	1.1 4.7	1.2	1.2 5.1
Sound Level dB(A) Half Load*	67	67	67	67
Engine Horsepower	12.9	10.7	14.0	11.6

*Typical RV installation. All readings at 10 ft. (3m).

Dimensions: (L x W x H in inches)

All Models: 33.6 x 22.2 x 16.7

Engine Detail:

4-cycle, OHV, 90-degrees V-Twin.

Power Capabilities: (at 100°F and 500' altitude)

- Marquis Gold 5500/5500 LP: Starts one 13500 BTU air conditioner with 3000-watt baseload. Or, two 13500 BTU air conditioners with 1300-watt baseload.
- Marquis Gold 7000/6500 LP: Starts two 13500 BTU air conditioners with 3000-watt baseload.

MARQUIS PLATINUM™ 5500



MARQUIS PLATINUM 7000



Marquis Platinum

- Electronic fuel injection.
 - Improved hot and cold starts
 - Automatic altitude compensation
 - No carburetor gumming after storage
- Runs one or two 13500 BTU air conditioners with power to spare.
- Electronic governor.
- Fully integrated design makes it the quietest in its class.
 - Enclosed muffler
 - Low vibration levels
 - Self diagnostic capability to simplify troubleshooting
 - Digital voltage regulation for stability as appliance loads change
- Gasoline or LP-fueled.

Marquis Platinum Specifications						
Model	5500 EFI	5500 LP		7000 EFI	6500 LP	
Watts	5500	5500		7000	6500	
RPM	2400	2400		2880	2880	
Volts	120	120		120	120	
Hertz	60	60		60	60	
Amps	45.8	45.8		58.3	54.2	
Weight (lb)	279	279		290	294	
Avg. Fuel Consumption	(gal/hr)	(gal/hr) (lb/hr)		(gal/hr)	(gal/hr) (lb/hr)	
No Load	0.3	0.4	1.7	0.4	0.5	2.1
Half Load	0.6	0.8	3.4	0.7	0.8	3.4
Full Load	0.9	1.1	4.7	1.1	1.2	5.1
Sound Level dB(A)						
Half Load*	64	64		64	64	
Engine Horsepower	12.9	10.7		12.3	11.6	

*Typical RV installation. All readings at 10 ft. (3m).

Dimensions: (L x W x H in inches)

All models 33.6 x 22.2 x 16.7

Engine Detail:

4-cycle, OHV, 90-degree V-Twin.

Power Capabilities: (at 100°F and 500' altitude)

- Marquis Platinum 5500/5500 LP: Starts one 13500 BTU air conditioner with 3000-watt baseload. Or, two 13500 BTU air conditioners with 1300-watt baseload.
- Marquis Platinum 7000/6500 LP: Starts two 13500 BTU air conditioners with 3000-watt baseload.

QUIET DIESEL™ 5500



QUIET DIESEL 7500



QUIET DIESEL 12500



**SO QUIET AND SMOOTH RUNNING,
YOU WON'T BELIEVE THEY'RE DIESELS!**

Quiet Diesel 5500

- Runs one or two 13500 BTU air conditioners with power to spare.
- Compact design perfect for small diesel coaches.
- High-quality sine wave electrical output maximizes appliance efficiency.
- Self-diagnostic capabilities simplify troubleshooting.
- Enclosed muffler for easy installation and quiet operation.

7500/8000

- Runs two 13500 BTU air conditioners with power to spare.
- Computer-controlled variable speed operation – matches engine speed to load demand, minimizing noise level.
- High-quality pure sine wave electrical maximizes appliance efficiency.
- Self diagnostic capabilities simplify troubleshooting.
- Special sound-controlling housing encloses cooling system and muffler.
- Three-point, fully focalized mounting system reduces vibration.

10000/12500

- Runs two or three 13500 BTU air conditioners with power to spare.
- High-quality sine wave electrical output maximizes appliance efficiency.
- Self-diagnostic capabilities simplify troubleshooting.
- Special sound-controlling housing encloses cooling system and muffler.
- Three-point, fully focalized mounting system reduces vibration.

Quiet Diesel Specifications					
Model	5500	7500	8000	10000	12500
Watts	5500	7500	8000	10000	12500
Volts	120	120	120	120/240	120/240
Hertz	60	60	60	60	60
Amps	45.8	62.5	66.6	83.3/41.7	104.0/52.0
Weight (lb)	400	420	420	690	715
Avg. Fuel Consumption	(gal/hr)	(gal/hr)	(gal/hr)	(gal/hr)	(gal/hr)
No Load	.25	0.13	0.13	0.11	0.11
Half Load	.41	0.49	0.49	0.43	0.48
Full Load	.66	0.96	1.02	1.0	1.2
Sound Level dB(A) Half Load*	68	68	68	68	68
Engine Horsepower	10.7	16.6	16.6	27	27

***Typical RV installation. All readings at 10 ft. (3m).**

Dimensions: (L x W x H in inches)

5500: 34.5 x 22.4 x 20.3

7500/8000: 36.3 x 23.6 x 22.3

10000/12500: 41.4 x 24.5 x 27

Engine Detail:

4-cycle, 3-cylinder inline vertical, liquid-cooled diesel engine.

Power Capabilities:

- 5500: Runs two 13500 BTU air conditioners with 1500-watt baseload.
- 7500/8000: Runs two 15000 BTU air conditioners with 3100-watt baseload.
- 10000/12500: Runs three 15000 BTU air conditioners with a 4000-watt baseload.

ENERGY™ COMMAND



ONAN ENERGY COMMAND

is a new line of remote power management panels that provides worry-free control for Onan diesel, gas, or LP generators.

Installation Features:

- Compatible with Onan generators
- Easy to install in production
- Works with any type of battery
- Up to three individual start request inputs (for three air-conditioners, etc.)
- Menu allows customization and access to system data
- Magnetic overlay covers mounting screws for clean appearance
- Installation mounting hole location same as standard Onan remote
- Inputs for house and engine battery voltage
- Amp/Tyco connector

Onan Energy Command		
Model	20	30
Battery Monitoring		
House battery bank state of charge gauge	•	•
House battery bank voltage	•	•
Engine battery bank voltage	•	•
Generator Monitoring		
Digital generator hour meter	•	•
Manual start/stop switch with digital readout	•	•
Service reminders	•	•
Diagnostic text messages	•	•
Automatic Generator Starting Functions		
Programmable "quiet time"		•
Look-ahead battery top-off feature prior to "quiet time"		•
Auto start/stop on low/full battery		•
Auto start/stop for up to three air conditioning systems		•
Built-in memory for all programmable settings		•
Safety Feature		
Safety start inhibit feature		•
Compatibility With Onan		
Camp Power™	•	•
MicroLite™	•	•
MicroQuiet™	•	•
Marquis Platinum™	•	•
Marquis Gold™	•	•
Quiet Diesel™	•	•

EC-30 Only

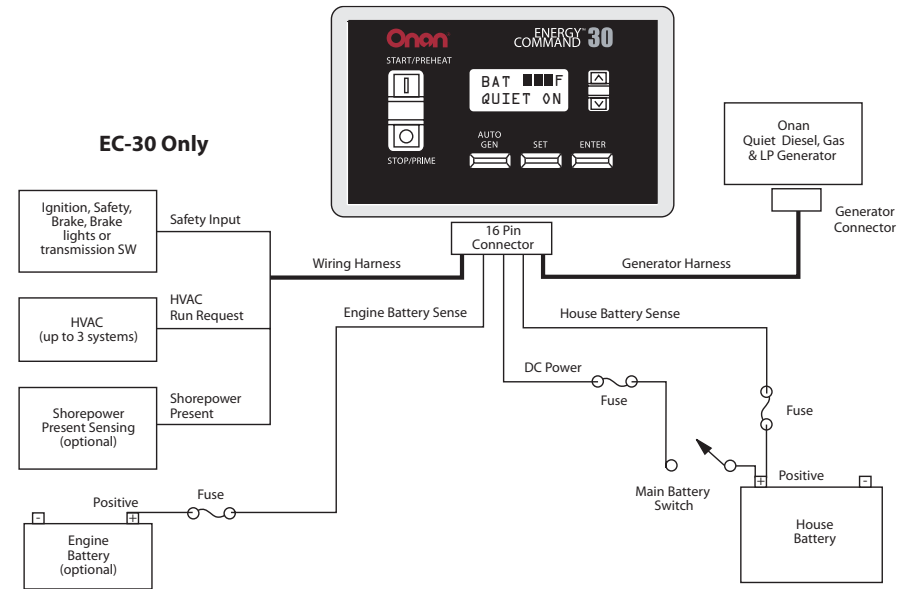

Specifications:

Voltage: 8-35VDC (Suitable for 12V or 24V systems)
 Current: 0.05A @ 12V (With backlight on)
 Dimensions: (Outside) 5.125" X 3.125" X 1.0"
 Opening: 3.875" X 2.5"
 Start/stop: Switch rated at 1.0 amp
 Control outputs: Rated at 1.0 amp

Models:

Energy Command 20 (#018-02020)
 Energy Command 30 (#018-02030)

Onan[®] EQUINOX™

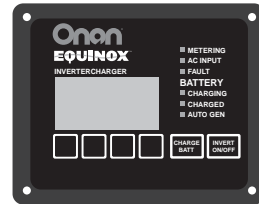

RV Inverter:

- Maintains full load output at high ambient temperatures
- 3-stage, temperature compensated battery charging and equalization for all battery types
- Low battery shut-off provides longer battery life
- Automatic generator start with programmable 'quiet time' helps maintain optimum battery levels and can start the generator on thermostat request for AC; included at no extra cost
- Battery charge rate 'power share adjust' gives appliances priority to reduce AC breaker trips
- AC and battery terminal blocks for easy installation and secure connections
- FCC Class B radiated EMI performance
- Automatically assumes load when AC power from generator or shore is not available
- Shunt option calculates battery state of charge and usage time remaining
- UL Listed to U.S. and Canadian Safety Standards

Remote Panel:

- Easy-to-use, full text, customer-friendly readout
- Easy-to-interpret diagnostics and fault history on remote panel
- LED lights provide inverter status at a glance
- 'Quick-key' for easy charge rate adjustments
- Full AC and DC metering

Onan Equinox Inverter - Size Comparison Chart

Model	1500 kW	2000 kW	2500 kW	3000 kW
INVERTER FUNCTION				
Max Continuous Output Power AC	1500	2000	2500	3000
Peak Current (Surge rated peak 300%)	37	50	62	75
CHARGER FUNCTION				
Max Charge Output DC Amps	75 A dc	100 A dc	120 A dc	140 A dc
Charge Control	3-Stage	3-Stage	3-Stage	3-Stage
Equalization	S	S	S	S
Battery Type Settings	wet/gel/agm	wet/gel/agm	wet/gel/agm	wet/gel/agm
Temperature Compensated Charging	S	S	S	S
TRANSFER SWITCH				
AC Transfer Switch Amps	30	30	30	30
SPECIFICATIONS				
Two Speed Forced Air Cooling	S	S	S	S
Specified Temperature Range	-20° C to +40° C			
Enclosure Type	Metal			
Dimensions (L x W x H)	12.2" x 12.8" x 7.3"			
Weight (lbs)	45	47	50	51
Recommended Class T DC Fuse	200 A	300 A	300 A	400 A
Remote Control Panel	O	O	O	O
30A Pass Thru	S	S	S	S
20/20 Breakers	O	O	O	O
15/15 Breakers	O	O	O	O
Internal Shunt (for battery level monitoring)	O	O	S	S
Auto Generator Start/Stop	S	S	S	S
Auto LowBatt Cutout	S	S	S	S
Power Sharing	S	S	S	S
Fault Diagnosis	S	S	S	S
Battery Voltage	12 V DC	12 V DC	12 V DC	12 V DC
AC Input Voltage	120 V AC	120 V AC	120 V AC	120 V AC
AC Output Connections	Terminal Block			
AC Input Connections	Terminal Block			

S=Standard, O=Optional



VII: FREQUENTLY ASKED QUESTIONS

Q: Can a generator charge my RV house battery?

A: Not directly. But a generator does provide power to operate your converter/charger, which charges batteries. Many diesel generators also have an alternator, which can charge batteries.

Q: Is it practical to power the roof air conditioner with my generator while traveling on the road?

A: Yes, that is what a generator is for, portable electrical power. In fact, it can help you economize on your vehicle fuel because the generator uses less fuel. Plus, it gives you an opportunity to exercise your generator. Any appliance that can be run in a stationary position can also be powered while driving.

Q: Can I run my generator for extra power while I'm hooked up to shore power at a campground?

A: Only if the RV manufacturer has supplied a separate circuit for a second air conditioner. However, in most RVs with two air conditioners, only one will operate while plugged into commercial shore power. By the NFPA code you cannot connect both power sources, generator power and commercial shore power, together. RV electrical systems are designed to separate these two power sources. However, with your comfort and needs in mind, your RV manufacturer may have wired the RV to allow you to power your second air conditioner with your RV generator. Check your vehicle's operator manual.

Q: Why does a breaker trip and the rear air conditioner not work when I turn it on while the generator is running?

A: RVs with two air conditioners typically have a 20-amp circuit breaker for the rear air conditioner and a 30-amp breaker for all other loads (including the front air conditioner). The RV may be wired with the two circuits reversed, causing the breaker to trip. The generator connections and wiring should be checked by an authorized service location.

Q: Is generator power clean enough to run a computer?

A: Yes, with Onan® and Camp Power™ generators this is no problem. The set should be turned on and warmed up before turning on the computer. The normal precautions for home use should be followed for RV use as well.

Q: Can I operate an air conditioner and microwave at the same time?

A: Although this is possible in lower temperatures or altitudes or with high efficiency AC's, Onan and Camp Power 2500 and 2800 watt generators will probably be overloaded when the AC cycles off and on with the microwave running. Load shedding devices are available that automatically turn off the AC when the microwave starts and then restarts it when power is available again. All other Onan and Camp Power generators can operate both of these appliances at the same time.

Q: Will high efficiency (power saver) air conditioners provide more reserve power?

A: YES. High efficiency AC's use 30% less power and are easier to start. That means more power is available for use in the RV or for better fuel economy. High efficiency AC's also have higher cooling output than comparable standard AC's.

Q: What happens if I "short-cycle" my air conditioner?

A: Short cycling refers to stopping and restarting the air conditioner compressor before the refrigerant pressure has enough time to equalize. If this happens, one of several things can occur: a circuit breaker may trip, either on the generator or at the breaker panel; the generator engine may stall; the AC compressor may trip its overload. AC compressors should remain off for at least 3 minutes before being restarted.

Q: Will increasing the speed (accelerating the RPM) on my generator provide more power potential?

A: No, and it may damage your generator and appliances.

Q: Can I run an RV generator in a National Park?

A: Yes. Onan® and Camp Power™ installed generators are quieter than the National Park sound level requirements. (During allowable hours of use.)

Q: What is carburetor icing? What conditions cause it? How can it be prevented?

A: Carburetor icing occurs in damp, cool outside conditions, causing rough operation, stalling and throttle sticking. If your generator is equipped with a summer/winter lever, operate the generator in the “winter” position in humid temperatures of 55°F or less. This will pre-heat the intake air so ice won’t form in the carburetor.

Q: Once the generator is started, should it continue to run for a certain length of time?

A: Ideally, Onan and Camp Power generators should run for a minimum of 30 minutes to give them a chance to warm up. Once warmed up, running your generator for five-minute intervals should be fine. But remember to turn on some appliances so the generator works while it’s running. Running it for more than 30 minutes at no load only burns fuel unnecessarily and adds costly maintenance.

Q: How are “will-fit” generator replacement parts different from Green Label Parts™?

A: Onan genuine Green Label Parts™ are tested and designed specifically for RV applications. Will-fit parts and gaskets can be the correct shape, but because of inadequate design, the wrong material, or poor quality, they could cause premature failure, leakage or performance problems. Use of some non-Onan replacement engine parts may affect the unit’s emissions certification, and damage caused by use of oil and air filters other than Green Label Parts is not covered under your generator warranty.

Q: How often should I perform maintenance on my generator? Will doing it myself affect my warranty?

A: The Operator’s Manual that accompanies each generator outlines proper maintenance procedures and intervals. If you follow the procedures correctly, warranty coverage remains intact. However, proper maintenance will obviously affect warranty coverage. For more information, see the Maintenance Intervals charts on page 15.

Q: How frequently should I change oil if I won’t be using the generator for several months?

A: Typically just like a car, change oil for seasonal temperature changes. For long storage, see your Operator’s Manual for extended out-of-service protection.

Q: Should I use straight 30-weight oil or is the multi-viscosity oil I use in my vehicle okay?

A: For best generator performance, we recommend you use OnaMax™ the Green Label Parts oil specifically formulated for RV generators. However, you can use the same oil you use in your vehicle engine provided it meets or exceeds SG/CE API specifications. To get you off to a good start, all new Onan and Camp Power generators are factory prepared with OnaMax 15W-40 oil.

Q: Will high-octane gasoline reduce the amount of fuel varnish?

A: No, because varnish is a form of fuel degradation that is not a function of octane level. Rather, it is a function of fuel quality, age and additive treatment. High-octane fuel without stabilizer additive will oxidize or varnish at a faster rate than fuel treated with a fuel stabilizer.

Q: When I’m checking my oil, does the dipstick need to be screwed in all the way?

A: In order to get the correct oil level reading, the dipstick must be screwed in completely on all models with a screw-type dipstick, except for the 2800 and 2500 MicroLite™ and Camp Power models; it sits on top of the fill tube. Make sure the vehicle is level when checking oil level.

Q: Do diesel generators need exercising like gasoline generators?

A: Yes, it helps lubricate the seals and engine components and keeps carbon from building up. Regular exercise also heats up the generator windings and removes or expels excess moisture. In sets equipped with brushes, exercising helps prevent corrosion build up on the slip rings.

Q: How do I keep mice/rodents out of my generator during storage?

A: Use rodent prevention techniques around the generator/compartments just as you would with any other area of your RV.

Q: Should I get an LP or a diesel generator for my diesel motorhome? What are the differences?

A: Each fuel option has its own advantages. LP generators generally have a lower initial cost than diesel units. Plus, they're smaller and lighter weight, allowing for more flexibility in the floor plan of large RVs. LP generators also have less exhaust fume smell. Diesel generators have a much longer engine life. They consume less fuel, and diesel fuel usually costs less than LP, which brings additional savings. A diesel generator gives you a common fuel system, and the convenience of operating your generator from the vehicle's main fuel supply. The generator best for you depends on how you use it and your own personal preferences.

Q: How is LP fuel supplied to my generator?

A: LP fuel is stored in the fuel tank in liquid form with some vapor at the top of the tank at relatively high pressure. The pressure in the tank is determined by the ambient (outdoor) temperature. The higher the temperature the higher the pressure. Ambient heat vaporizes fuel until the pressure won't allow any more liquid to vaporize. The tank pressure will be about 200 psi at 110°F, 70 psi at 40°F, and 0 psi at -40°F.

In order for the fuel to be burned at a controlled rate in the generator (or any other appliance) it must be converted to a vapor form and supplied at a controlled pressure.

LP fuel systems for many Onan® generators are available in two forms, vapor withdrawal and liquid withdrawal.

Q: What is the difference between LP Vapor and LP Liquid Fuel Systems?

A: LP Vapor Withdrawal – With a vapor withdrawal system, the LP fuel is vaporized in the fuel tank by heat input from the environment. The pressure is reduced to about 11-inches of water column (0.4 psi) at the tank outlet with a regulator. The vaporized LP fuel flows to the demand regulator on the generator, which reduces the pressure before it enters the carburetor.
LP Liquid Withdrawal – With a liquid withdrawal system, liquid LP fuel flows at tank pressure to the generator where heat from the generator converts the fuel from liquid to vapor form. A two-stage regulator reduces fuel pressure before it enters the carburetor.

Q: What are the advantages of each type of LP fuel system?

A: LP Vapor Withdrawal

- Simpler system for the generator set.
- Same low-pressure vapor system as other appliances.

LP Liquid Withdrawal

- Better operation in cold temperatures.
- Complete vaporization pressure regulation system is on the generator from the factory.

Q: Can LP fuel plug up the regulator?

A: The most common contaminants found in LP fuel are the oils from the LP pumping facility. The oil is removed from LP fuel at the location the fuel vaporizes. In liquid withdrawal LP fuel systems, this occurs in the regulator. Oil contaminants can then clog the regulator. The Marquis Platinum™, Marquis Gold™ and Emerald Advantage™ liquid withdrawal LP fuel systems provide a drain for oil removal. See your Onan Authorized RV Service and Parts Dealer for assistance.

Q: Can I use the Camp Power 4000, MicroQuiet 4000 or Emerald 4000 generator to run two air conditioners?

A: No.

Q: Will the starter motor continue to be engaged if the start button is held too long?

A: All Onan and Camp Power™ generators are equipped with a start disconnect feature which will not allow the starter to crank once the generator is producing electrical output.

Q: Why don't I have as much power as I think I should?

A: Battery chargers run as "invisible" loads, and can draw as much power as two air conditioners, depending on size. This can continue for several hours, depending on battery charger and battery bank size.

Special Camp Power Section

Q: Is the muffler included on or with the Camp Power™ generator?

A: No. Required muffler kits are available for each Camp Power model. See your distributor for more information on proper application for each kit.

Q: How many appliances can I operate with my Camp Power 2800 or 2500 LP generator?

A: The Camp Power 2800 can run a 13500 BTU air conditioner with 600-watts of power in reserve. In most trailers and truck campers, that is enough reserve to operate the DC converter (for TV, lights, fans, battery charger) in addition to the air conditioner. The 2500 LP model has slightly less reserve but still enough power for an air conditioner plus converter loads. With the AC off, both Camp Power generators can operate any mix of standard RV appliances (i.e. microwave, coffee maker, hairdryer, etc.) up to the rated capacity.

Special Marquis Platinum™ Electronic Fuel Injection (EFI) Section

Q: How reliable is the technology for electronic fuel injection? Will I have more problems?

A: No, you won't have more problems. Actually, you'll have less. The EFI technology used in our Marquis Platinum™ is the same technology used in the automotive industry for over 10 years.

Q: Should I worry about gumming of the fuel system with my EFI generator?

A: No. Your EFI generator minimizes fuel system gumming. This will minimize maintenance and service requirements, and make storage of your RV much simpler.

Q: Does a generator with EFI start better?

A: The Marquis Platinum EFI generator is much faster and more reliable in both hot and cold starting. This will result in fewer start failures.

Q: Do I have to adjust for altitude and temperature with EFI?

A: No, the Marquis Platinum EFI generator has automatic altitude and temperature compensation.

RECORD WHEN SCHEDULED MAINTENANCE IS PERFORMED

Service Item	Generator Maintenance Record							
	Service Intervals - Repeat Every							
	Mthly	50 Hrs	100 Hrs	150 Hrs	200 Hrs	250 Hrs	450 Hrs	500 Hrs
Clean & Check Battery & Connections								
Clean Spark Arrestor								
Change Oil/Oil Filter								
Change Air Filter								
Replace Spark Plugs								
Change Fuel Filter								
Schedule Onan Service Center Tune-Up								

NOTE: See page 15 for General Generator Maintenance Intervals Chart

When contacting an Onan Authorized RV Service and Parts Dealer for service, maintenance or parts questions, always refer to the complete model, spec and serial number of your Onan RV generator. These numbers are printed on your Onan generator unit nameplate. Write them in below for easy reference.

Model No:

Serial No:

The Original Paul Bunyan and Babe the Blue Ox in Bemidji, Minnesota



BETWEEN STRANGER, TEXAS, AND FRIEND, OREGON,

THERE'S 2,190 MILES AND PLENTY OF NEW CHARACTERS TO MEET.

PAUL
BUNYAN
1937

©2005 Cummins Power Generation. Cummins and Onan are registered trademarks and Coach Care is a trademark of Cummins Inc.



WIPING OUT ON THE TRAIL DOESN'T HURT
NEARLY AS MUCH AS SITTING AROUND
A CAMPFIRE SINGING SONGS.

©2005 Cummins Power Generation. All Rights Reserved. Onan is a registered trademark of Cummins Inc. "Outlet Boy", "It's good and saving" and "The quiet one" are trademarks and/or service marks of Cummins Inc.

Onan is with you all the way. Wherever you go, whatever you do, Onan's full line of generators give you the power to get the most fun out of each trip. Look to Onan for all your on-the-road maintenance needs, too. For one-stop service or repair help, our network of Coach Care™ Service Centers are located coast-to-coast. Plus, you'll find over 700 Onan-Authorized RV Service and Parts Dealers everywhere in between. Find your nearest location at www.funroads.com.



Just because riding an ATV or kayaking or whatever takes you out of the city, there's no reason to leave civilization. Get an Onan® generator and bring the comforts of home with you. Onan is the generator of choice for top RV manufacturers. They're quiet, reliable and built especially for RVs. Like Outlet Boy™ always says, "Extreme sports is one thing, extreme discomfort is something else." Power up the adventure with Onan. Check out www.funroads.com/powerup



Glen, Jenni, Remus, and their Onan generator travel over 10,000 miles a year. That's over 70,000 in dog miles.

Onan
The quiet one.



Onan
The quiet one.