



**DANGER**

**Danger of electrical shock, burns or death.** Always remove all power sources before attempting any repair, service or diagnostic work. Power can be present from shore power, generator, inverter or battery. All power sources must be disabled and secured before performing any service.



**CAUTION**

If you lack the skills, tools or equipment to perform diagnostic or repair work leave such work to an authorized Winnebago Industries dealer or other qualified shop.

DWG NO.	FEATURE
144704-01	-----
144704-11	(1B1) (12D)
144704-15	(265) (12D)
144704-30	(04L) (12D)

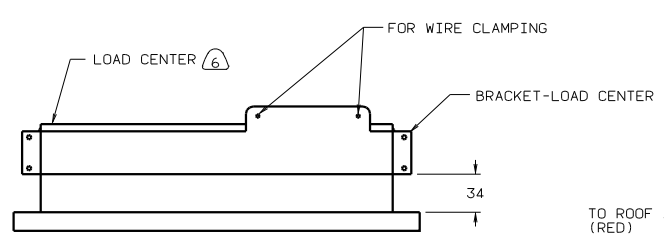

VIEW AA-AA

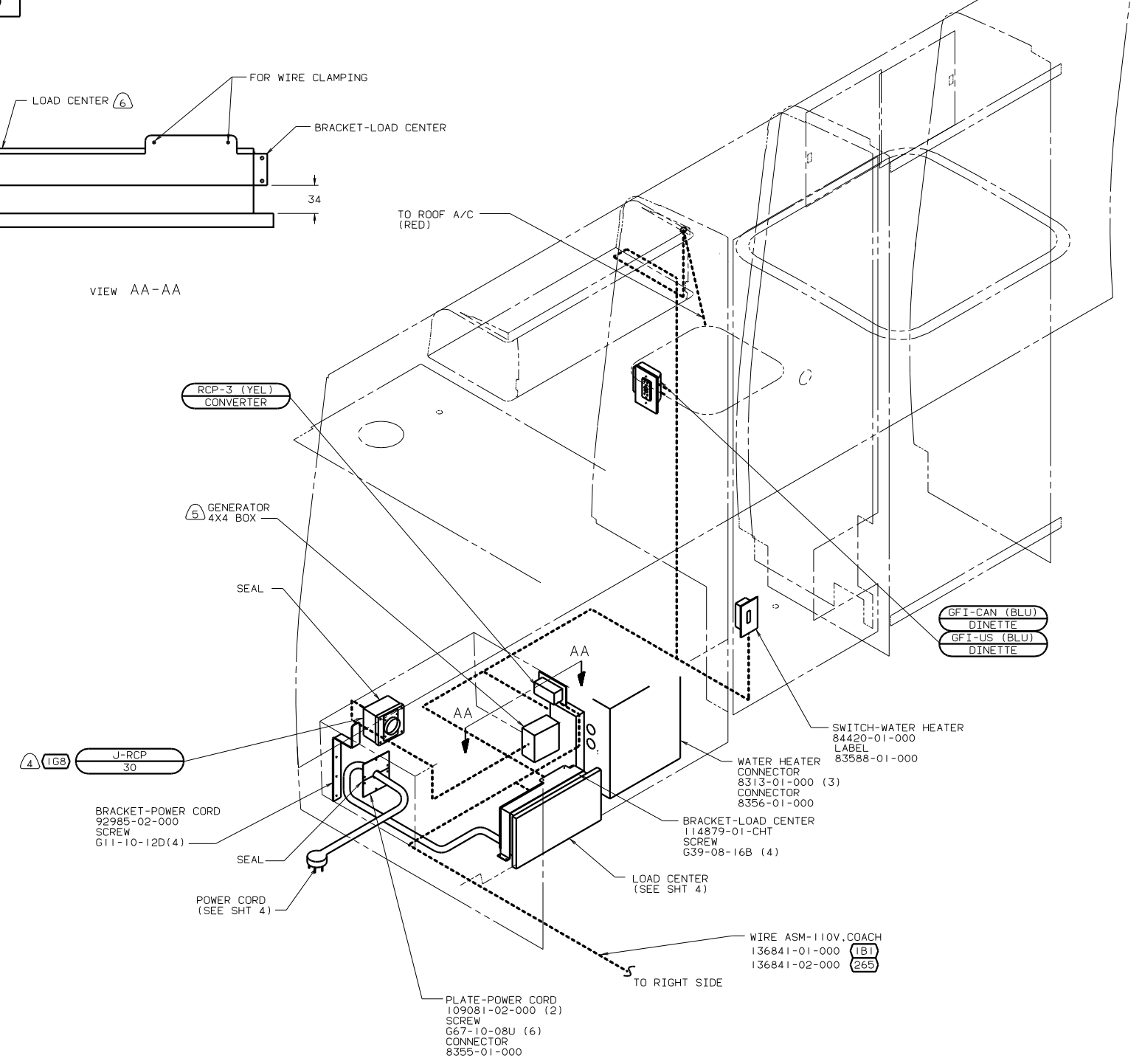

- (6) LOCATE LOAD CENTER WITHIN DINETTE SEAT FACE.
- (5) SEE GENERATOR INSTL FOR ADDITIONAL INFORMATION.
- (4) INSTALL RCP WITH GROUND TOWARD BOTTOM OF VEHICLE.
3. ALL GROUND WIRES TO BE COVERED WITH TUBING 8041-02-000.
2. ALL WIRES ARE TO BE CLAMPED WITH CLAMP 10497-05-000 WITHIN 200 OF OUTLET BOXES, USE SCREW G67-10-12B.
1. ALL WIRES TO BE CLAMPED WITH CLAMP 10495-01-000 OR CLIP 80734-01-000 EVERY 600, USE SCREW G67-10-12B UNLESS OTHERWISE SPECIFIED.

- (1G8) GEN-2.8KW ONAN MICROLITE
- (29K) A/C ROOF-ONE 7,100 BTU
- (12D) ELECTRICAL SYSTEM 30 AMP
- (265) CODES/STANDARDS-CSA/CMVSS
- (1B1) CODES STANDARDS/USA

(1B1) (12D) (265) (29K)

FOR ELECTRICAL TORQUE SPECIFICATIONS SEE DWG NO. 128783-01-000

(X-X) FOR ELECTRICAL CALLOUTS SEE DWG NO. 121339-01-000

COPYRIGHT 2003 WINNEBAGO INDUSTRIES, INC. **WINNEBAGO** 04 2220D

DATE	UNSPECIFIED TOLERANCES ARE:	MATERIAL:
DATE	WHOLE DIM (XX)	
DATE	ONE-PLACE (X.X)	
DATE	TWO-PLACE (X.XX)	
DATE	ANGLE	
DATE	THIRD ANGLE PROJECTION	

LAYOUT NO. ----- TITLE: WIRING INSTL-BODY, 110V (L30)

DIA # SCALE: NONE 100 NOT SCALE DRAWING SIZE DWG NO. 144704

ALL DIMENSIONS ARE IN MILLIMETERS SHEET 1 OF 5

REF: 141375 A | 08/11/03

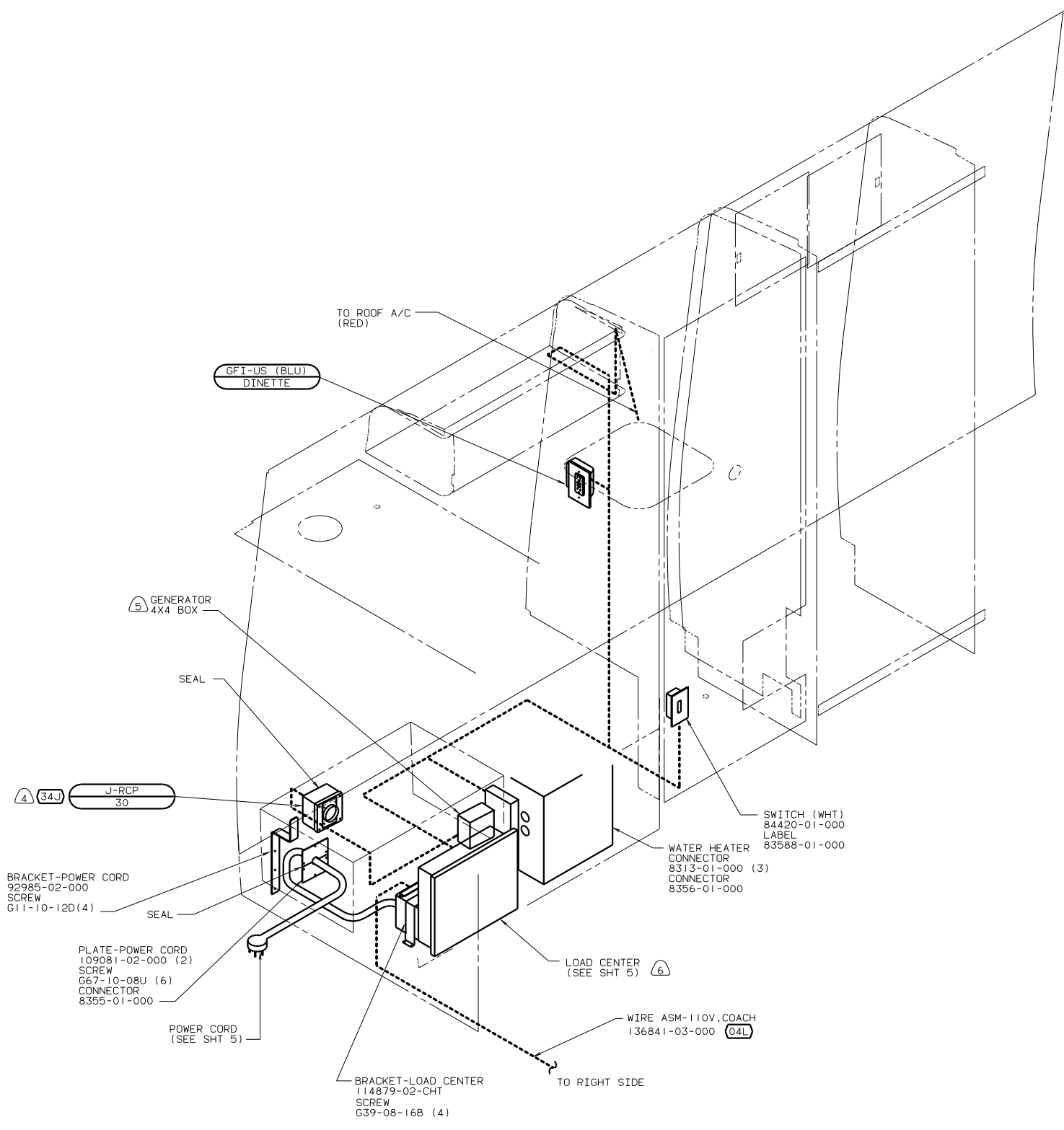

- 6 LOCATE LOAD CENTER WITHIN DINETTE SEAT FACE.
- 5 SEE GENERATOR INSTL FOR ADDITIONAL INFORMATION.
- 4 INSTALL RCP WITH GROUND TOWARD BOTTOM OF VEHICLE.
3. ALL GROUND WIRES TO BE COVERED WITH TUBING 8041-02-000.
2. ALL WIRES ARE TO BE CLAMPED WITH CLAMP 10497-05-000 WITHIN 200 OF OUTLET BOXES, USE SCREW G67-10-12B.
1. ALL WIRES TO BE CLAMPED WITH CLAMP 10495-01-000 OR CLIP 80734-01-000 EVERY 600, USE SCREW G67-10-12B UNLESS OTHERWISE SPECIFIED.

NOTES:

- 34J GEN-2.8KW GENERAC 100V
- 29K A/C ROOF-ONE 7,100 BTU
- 12D ELECTRICAL SYSTEM 30 AMP
- 04L JAPAN EXPORT PACKAGE

FOR ELECTRICAL TORQUE SPECIFICATIONS SEE DWG NO. 128783-01-000

FOR ELECTRICAL CALLOUTS SEE DWG NO. 121339-01-000

04L 12D 29K 04 222QD

TITLE WIRING INSTL-BODY, 110V (L30JPN)

00 WT SCALE ORIGIN 1121 Ie No 144704

SHEET 2 OF 5

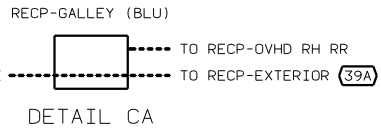
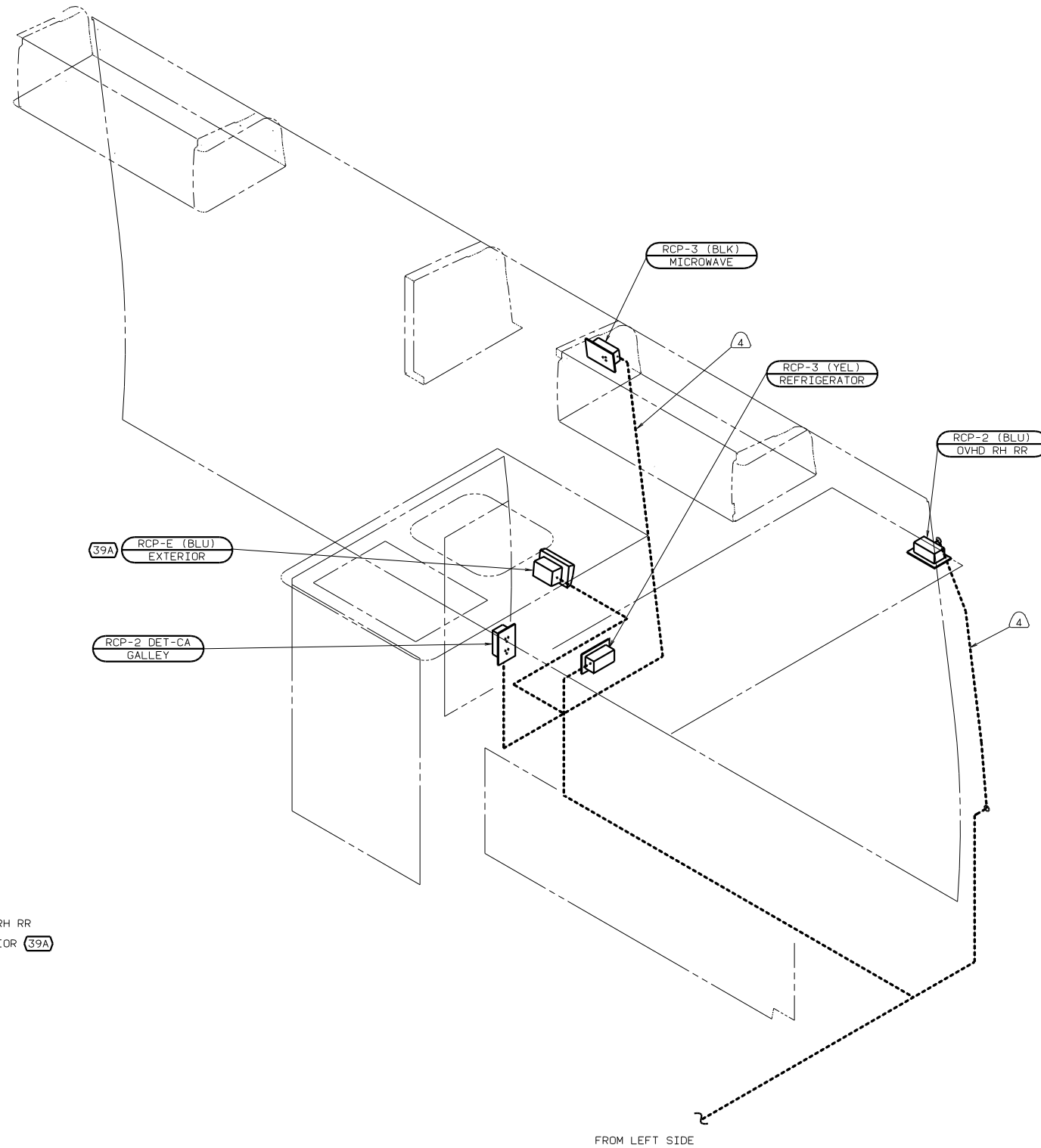

- NOTES:
- ④ ROUTE WIRE THRU SIDEWALL.
  - 3. ALL GROUND WIRES TO BE COVERED WITH TUBING 8041-02-000.
  - 2. ALL WIRES ARE TO BE CLAMPED WITH CLAMP 10497-05-000 WITHIN 200 OF OUTLET BOXES, USE SCREW G67-10-12B.
  - 1. ALL WIRES TO BE CLAMPED WITH CLAMP 10495-01-000 OR CLIP 80734-01-000 EVERY 600, USE SCREW G67-10-12B UNLESS OTHERWISE SPECIFIED.

FOR ELECTRICAL TORQUE SPECIFICATIONS SEE DWG NO. 128783-01-000

FOR ELECTRICAL CALLOUTS SEE DWG NO. 121339-01-000

- ④L JAPAN EXPORT PACKAGE
- ③9A EXT RECEPTACLE DPLX 120VAC
- ①2D ELECTRICAL SYSTEM 30 AMP
- ②65 CODES/STANDARDS-CSA/CMVSS
- ①B1 CODES STANDARDS/USA

①B1 ②65 ①2D 04 2220D  
 TITLE: WIRING INSTL-BODY, 110V(R30)  
 DWG NO 144704  
 SHEET 3 OF 5

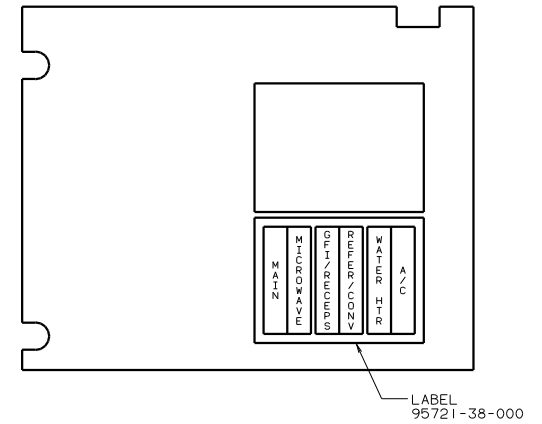
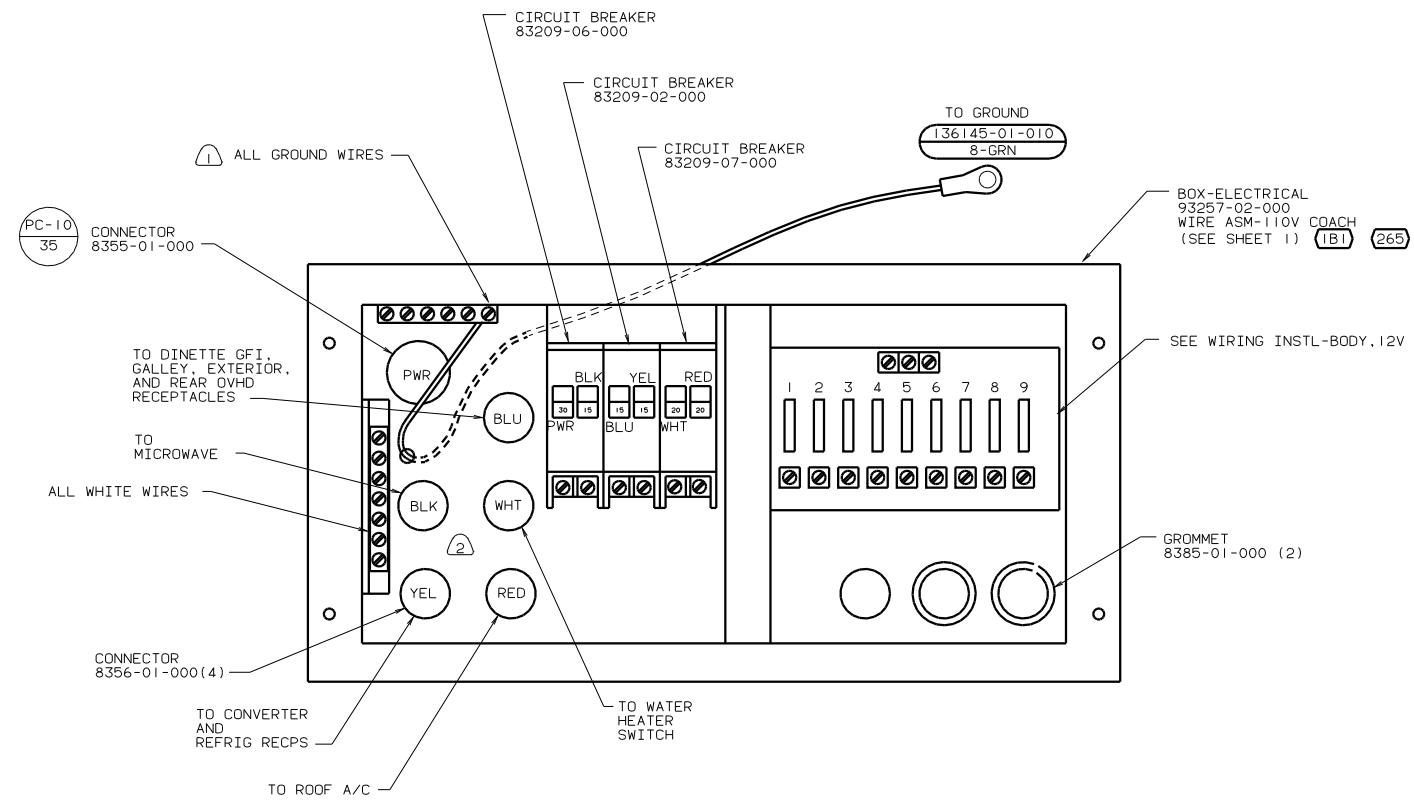

NOTES:  
 (2) 110V CABLES IN LOAD CENTER SHALL BE 200 LONG.  
 (1) ALL GROUND WIRES TO BE COVERED WITH TUBING 8041-02-000.

FOR ELECTRICAL TORQUE SPECIFICATIONS SEE DWG NO. 128783-01-000

(X-X)

FOR ELECTRICAL CALLOUTS SEE DWG NO. 121339-01-000

(12D) ELECTRICAL SYSTEM 30 AMP  
 (265) CODES/STANDARDS-CSA/CMVSS  
 (1B1) CODES STANDARDS/USA  
 (1B1) (12D) (265) 04 2220D

TITLE: WIRING INSTL-BODY, 110V(LC30)  
 DWG No 144704  
 SHEET 4 OF 5  
 08/11/03

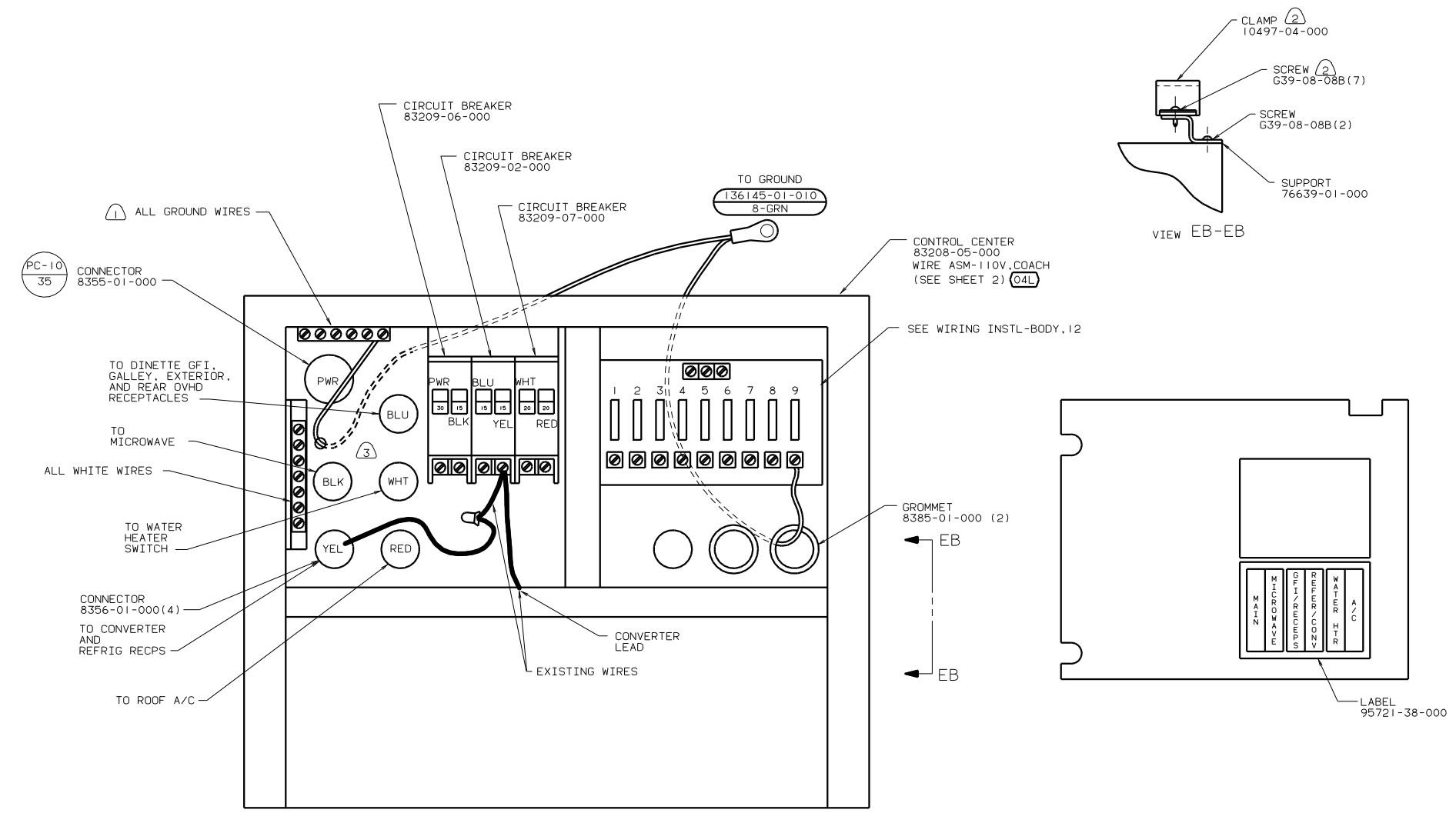

- NOTES:
- ③ 110V CABLES IN LOAD CENTER SHALL BE 200 LONG.
  - ② FASTEN ALL WIRES TO SUPPORT. USE ONE SCREW PER CLAMP.
  - ① ALL GROUND WIRES TO BE COVERED WITH TUBING 8041-02-000.

FOR ELECTRICAL TORQUE SPECIFICATIONS SEE DWG NO. 128783-01-000	(X-X)	FOR ELECTRICAL CALLOUTS SEE DWG NO. 121339-01-000
--	-------	---

①2D ELECTRICAL SYSTEM 30 AMP  
 ④4L JAPAN EXPORT PACKAGE  
 ④4L ①2D 04 222QD

TITLE	WIRING INSTL-BODY (LC30JPN)
DO NOT SCALE DRAWING	SIZE
SHEET 5 OF 5	DWG NO 144704

08/11/03