



DANGER

Danger of electrical shock, burns or death. Always remove all power sources before attempting any repair, service or diagnostic work. Power can be present from shore power, generator, inverter or battery. All power sources must be disabled and secured before performing any service.



CAUTION

If you lack the skills, tools or equipment to perform diagnostic or repair work leave such work to an authorized Winnebago Industries dealer or other qualified shop.

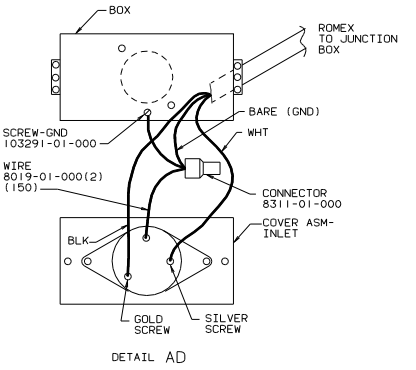
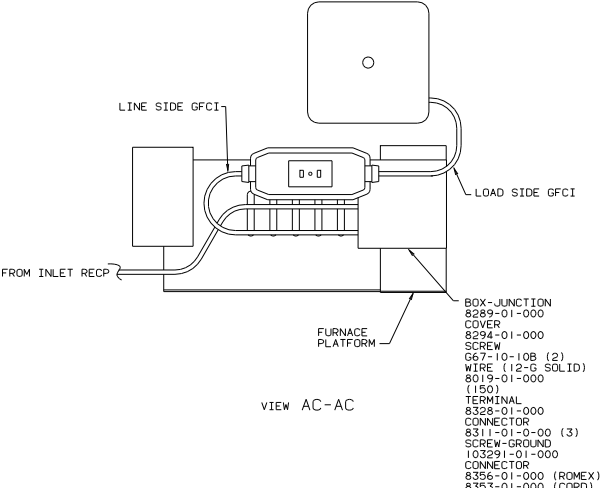
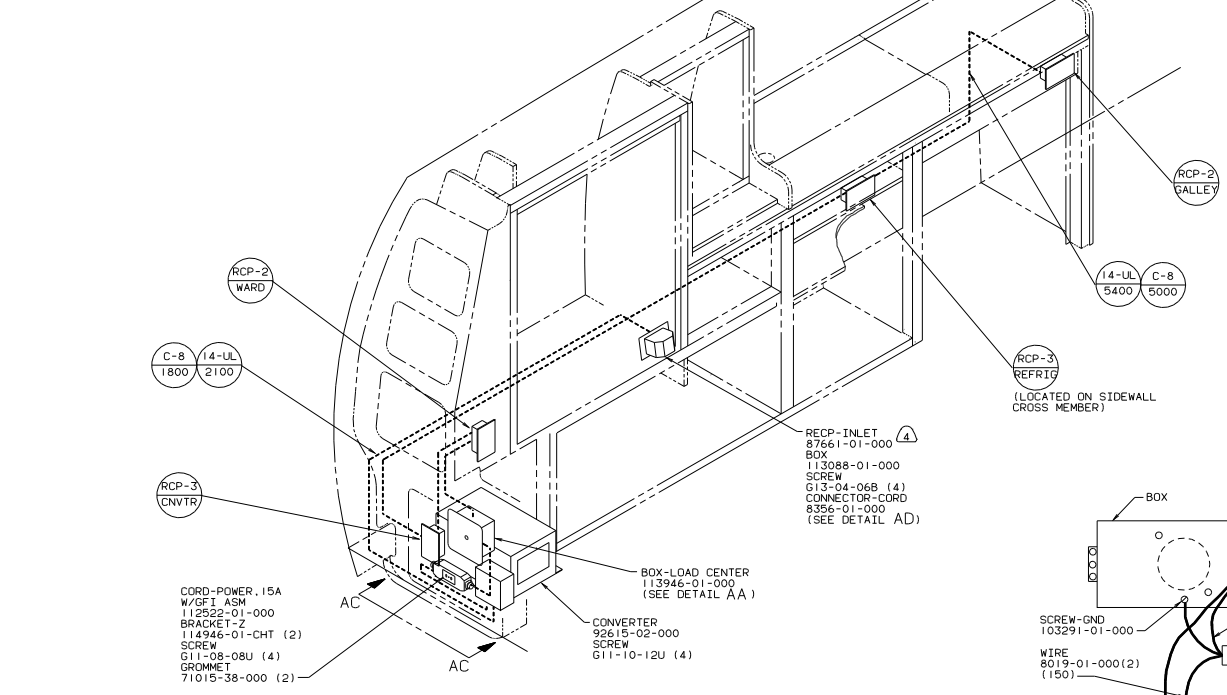
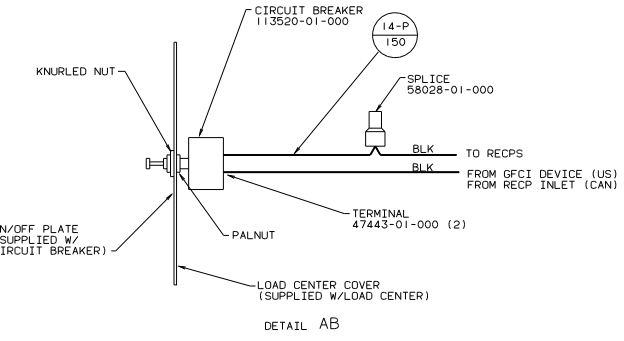
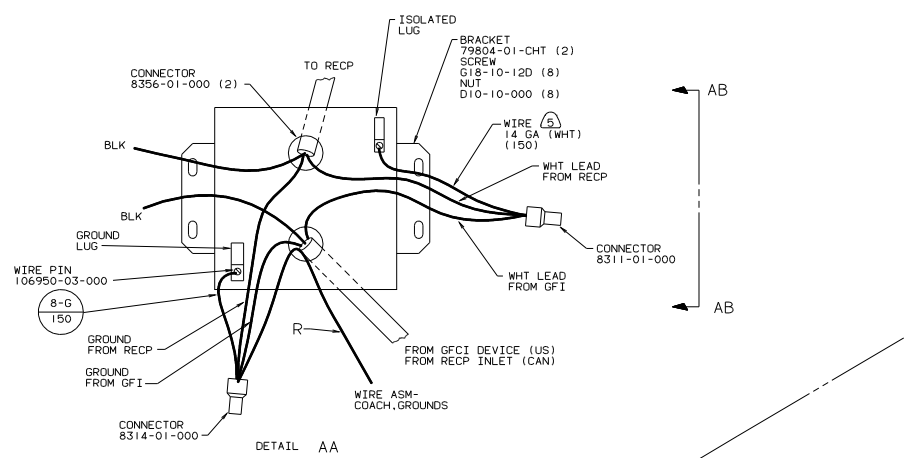

- NOTES:
- ③ LEAD IS TO BE MADE FROM WIRE 8027-01-000 (US) OR 8023-02-000 (CAN).
 - ④ CORD-POWER 87660-01-000 TO BE PROVIDED LOOSE, STORED IN RH REAR COMPT.
 - 3. ALL GROUND WIRES TO BE COVERED WITH TUBING 8041-02-000.
 - 2. ALL 110V WIRES ARE TO BE CLAMPED WITH CLAMP 104-05-000 WITHIN 200 OF OUTLET BOXES. USE SCREW G67-10-12B.
 - 1. ALL WIRES TO BE CLAMPED WITH CLAMP 10495-01-000 OR CLIP 80734-01-000 EVERY 500. USE SCREW G67-10-12B UNLESS OTHERWISE SPECIFIED.

(B) CODES/STANDARDS USA
 110V LEFT SIDE (US)

WINNERCO 99 1/2 117A

DATE	DATE	UNSPECIFIED TOLERANCES ARE:	MATERIAL
DRW	DATE	MAKE DIM 1/16"	
F.F.C.	DATE	2ND-PLACE 1/32"	
M.C.	DATE	3RD-PLACE 1/64"	
DATE	DATE	THIRD ANGLE PROJECTION	

LAPOW W.VVAN TITLE: WIRING INSTL-BODY 110 US
 104 # SCALE: NONE DO NOT SCALE DIMENSIONS SHEET NO. 131675
 ALL DIMENSIONS ARE IN MILLIMETERS SHEET 1 OF 5 I.E. NO.

(X-X) FOR ELECTRICAL CALLOUTS SEE DWG NO. 128783-01-000
 FOR ELECTRICAL TORQUE SPECIFICATIONS SEE DWG NO. 128783-01-000

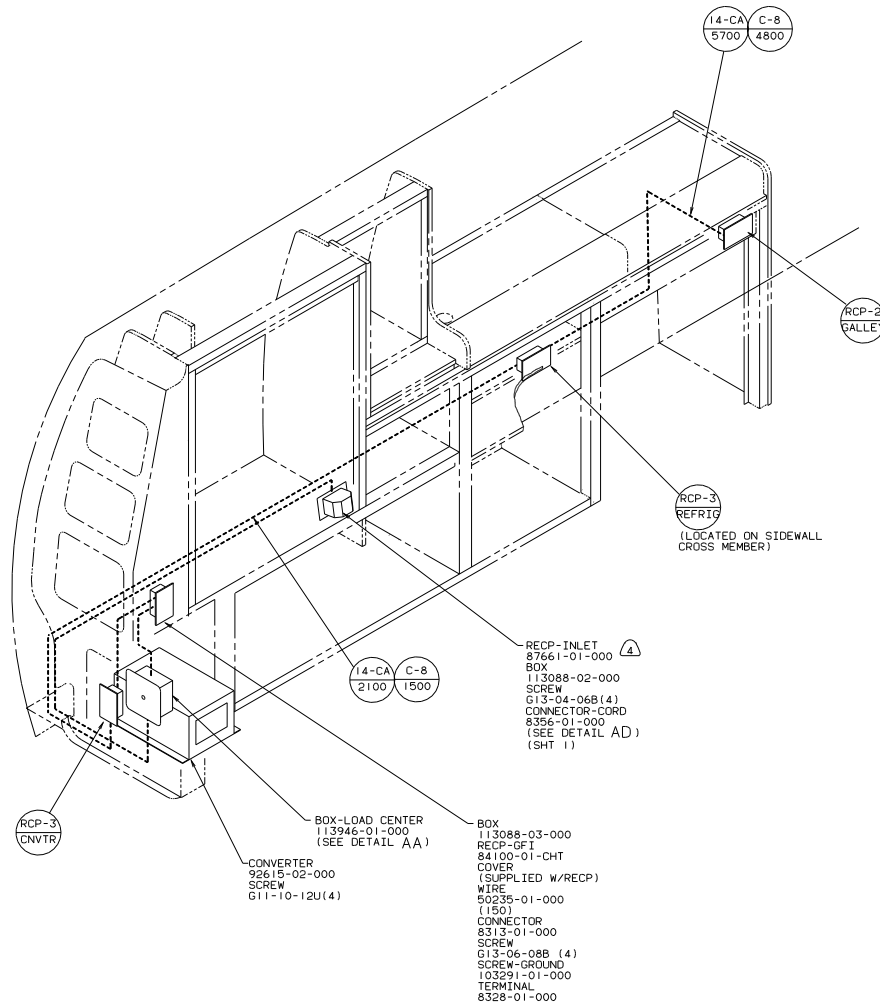

- 4 CORD-POWER 87660-01-000 TO BE PROVIDED LOOSE, STORED IN RH REAR COMPT.
3. ALL GROUND WIRES TO BE COVERED WITH TUBING 8041-02-000.
2. ALL 110V WIRES ARE TO BE CLAMPED WITH CLAMP 104-05-000 WITHIN 200 OF OUTLET BOXES. USE SCREW G67-10-12B.
1. ALL WIRES TO BE CLAMPED WITH CLAMP 10495-01-000 OR CLIP 80734-01-000 EVERY 500. USE SCREW G67-10-12B UNLESS OTHERWISE SPECIFIED.

NOTES:

(265) CODES/STANDARDS-CSA/CMVSS

110V LEFT SIDE (CAN)

99 1/2 117A

(X-X)
FOR ELECTRICAL CALLOUTS SEE DWG NO. 121339-01-000

FOR ELECTRICAL TORQUE SPECIFICATIONS SEE DWG NO. 128783-01-000

TITLE: WIRING INSTL-BODY 110 CA
DO NOT SCALE DRAWING SHEET 2 OF 5 I.F. NO 131675

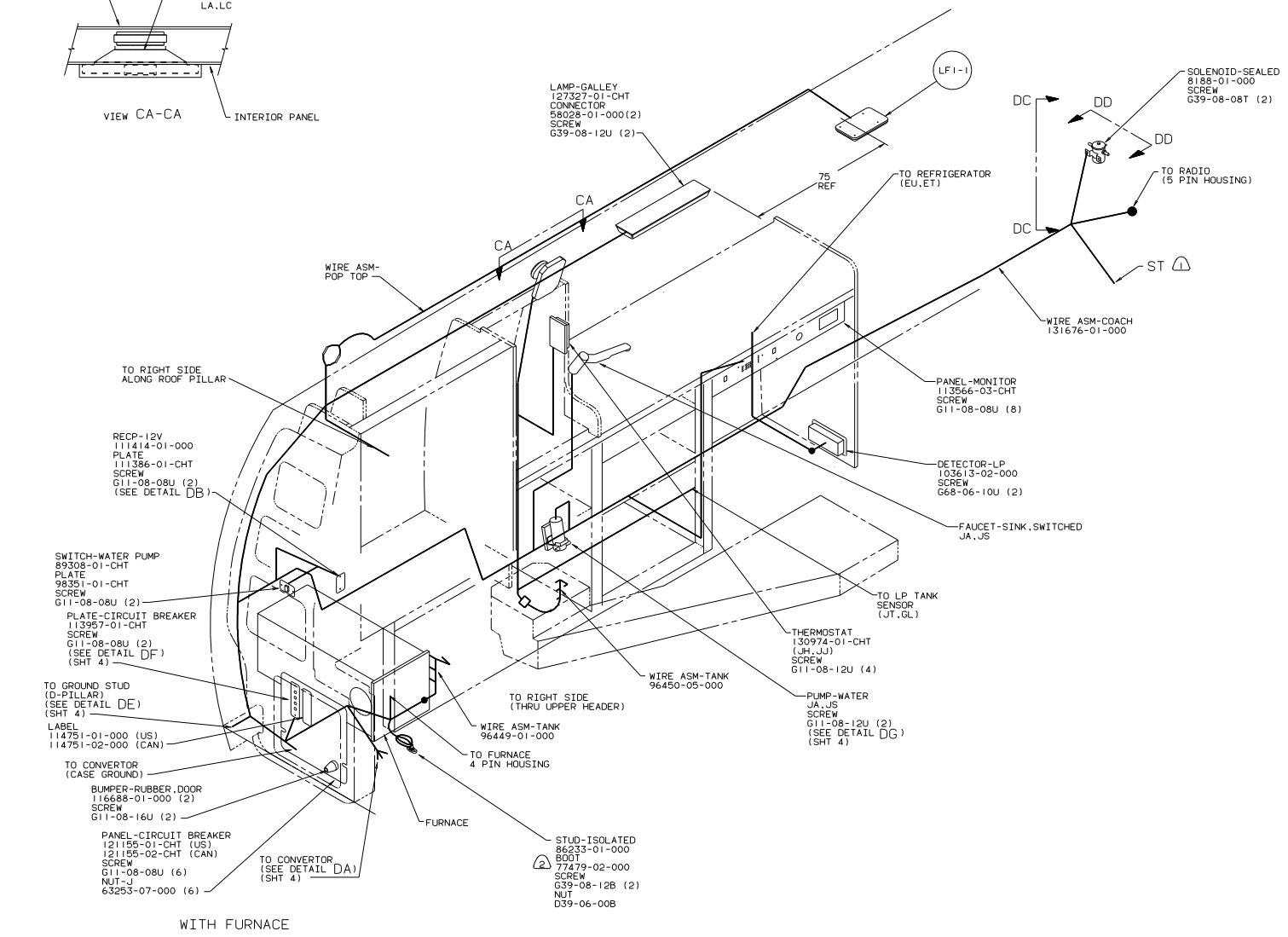
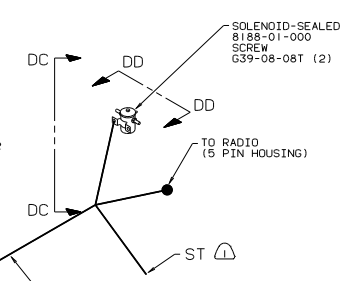
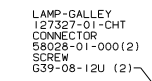

2) ALL WIRES TO PASS THRU SLEEVE IN BOOT.
1. CONNECTS TO YELLOW TERMINAL STRIP BLOCK,
LOCATED BEHIND VW FUSE BLOCK ASM, FUSE 54.

(265) CODES/STANDARDS-CSA/CMVSS
(1B1) CODES/STANDARDS USA
12V LEFT SIDE

(X-X)
FOR ELECTRICAL
CALLOUTS
SEE DWG NO.
121339-01-000

FOR ELECTRICAL
TORQUE
SPECIFICATIONS
SEE DWG NO.
128783-01-000

99 1/2 117A
WIRING INSTL-BODY (12V L)
DO NOT SCALE DRAWING
SHEET 3 OF 5

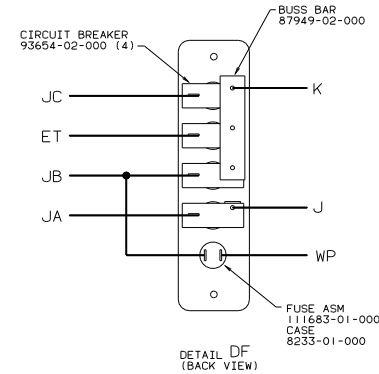
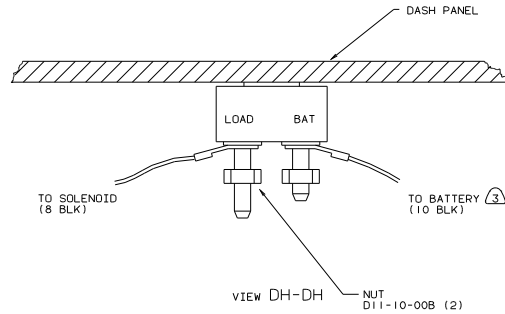
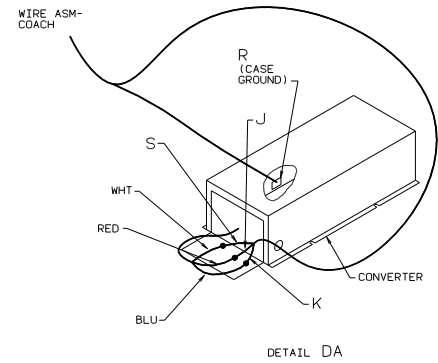
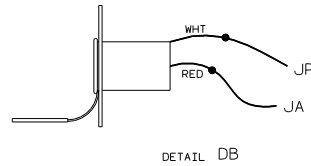
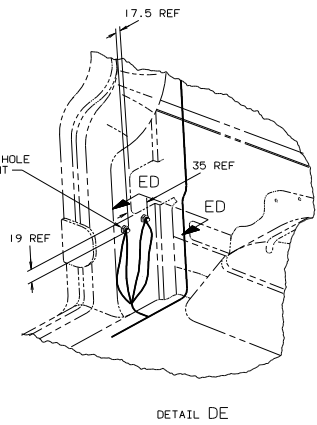
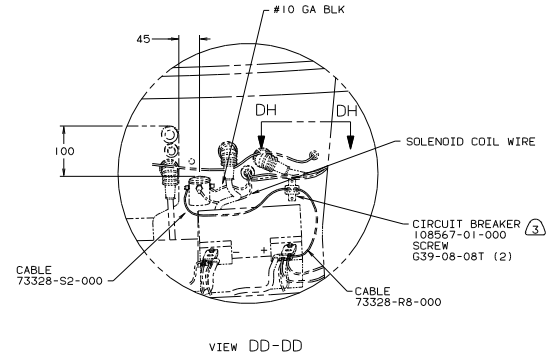
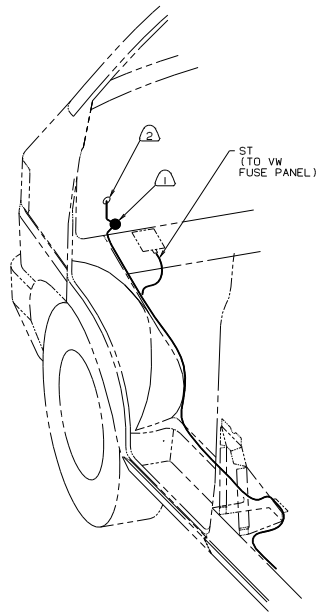
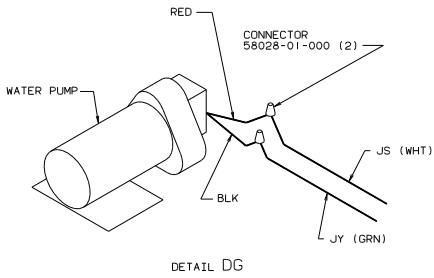

- NOTES:
- (3) LOCATION OF BATTERY LEAD ON CIRCUIT BREAKER IS CRITICAL FOR CORRECT OPERATION.
 - (2) ROUTE WIRE THROUGH FIREWALL WITH EXISTING VW WIRES.
 - (1) FUSE TO BE SECURED TO VW FUSE PANEL.

(265) CODES/STANDARDS-CSA/CMVSS
(1B1) CODES/STANDARDS USA

12V DETAILS
99 1/2 117A

(X-X) FOR ELECTRICAL CALLOUTS SEE DWG NO. 121539-01-000

FOR ELECTRICAL TORQUE SPECIFICATIONS SEE DWG NO. 128783-01-000

TITLE: WIRING INSTL-BODY (12V DTL)
DWG NO: 131675
SHEET 4 OF 5

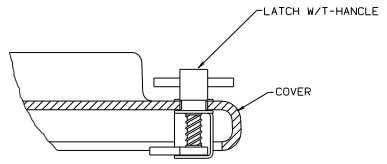

DETAIL EA-EA

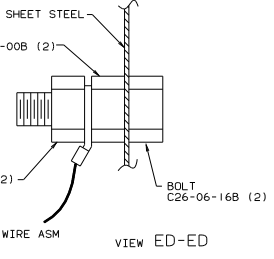

VIEW ED-ED

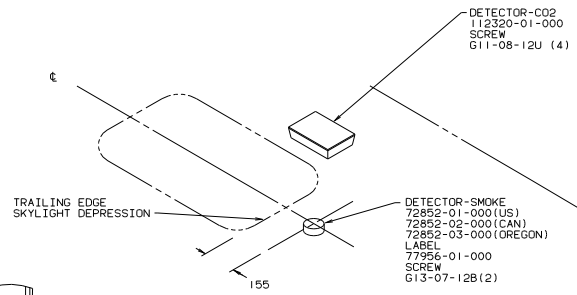

- LAMP-HEADLINER 112643-02-000(2)
- TRIM 112642-02-000(2)
- CONNECTOR 58028-01-000(4)
- SCREW G13-04-06B(8)

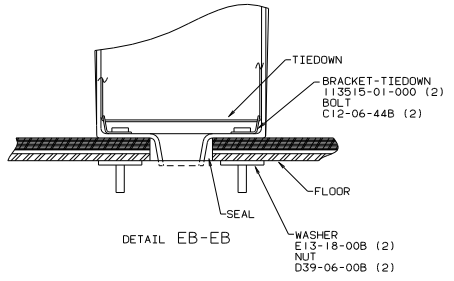

DETAIL EB-EB

- CONDUIT 41953-07-000 (150)

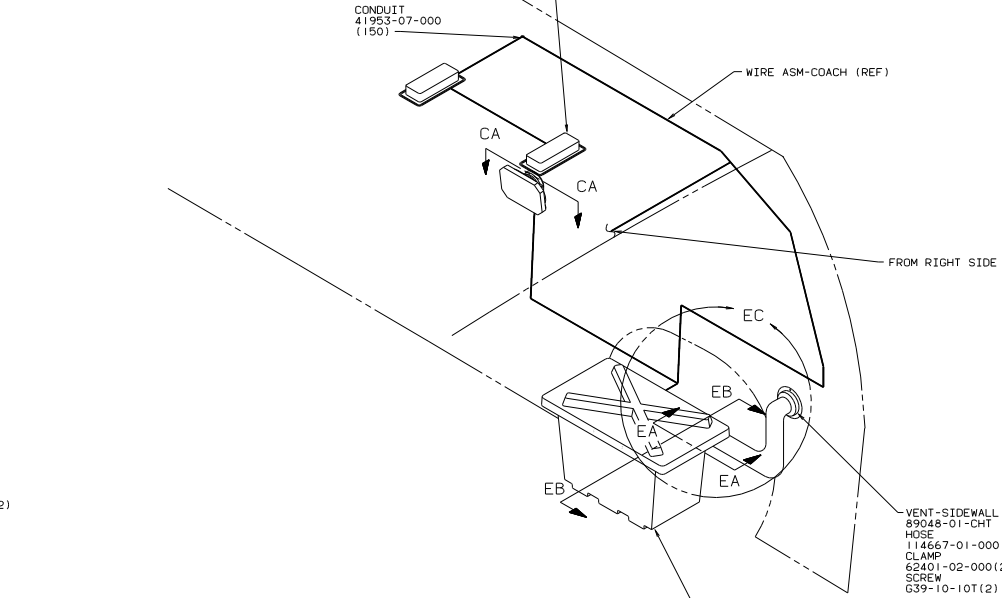

DETAIL EC

- BATTERY 63739-02-000
- WASHER E13-10-00B(2)
- TIEDOWN 84993-01-000
- COVER-BATTERY BOX 113514-01-CHT
- BOX-BATTERY SINGLE 111394-01-CHT
- LATCH-GRIP, ADJUSTABLE 113517-01-000
- RIVET H15-06-06R(2)
- SEAL 64075-07-000 (1335)

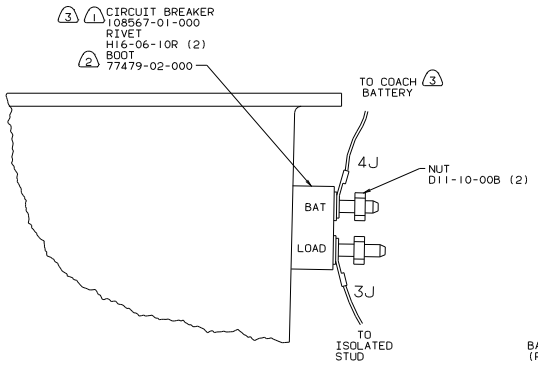

VIEW EE-EE

- 3 1 CIRCUIT BREAKER 108567-01-000
- RIVET H16-06-10R (2)
- BOOT 77479-02-000

- 3 LOCATION OF BATTERY LEAD ON CIRCUIT BREAKER IS CRITICAL FOR CORRECT OPERATION.
- 2 BOTH WIRES TO PASS THRU SLEEVE IN BOOT.
- 1 LOCATION OF COACH BATTERY CIRCUIT BREAKER IS CRITICAL FOR CORRECT OPERATION.

- 442 ENT CTR INTERIOR W/CASSETTE
- 265 CODES/STANDARDS-CSA/CMVSS
- 1B1 CODES/STANDARDS USA

12V RIGHT SIDE (US/CAN)

99 1/2 117A

(X-X) FOR ELECTRICAL CALLOUTS SEE DWG NO. 121339-01-000

FOR ELECTRICAL TORQUE SPECIFICATIONS SEE DWG NO. 128783-01-000

WIRING INSTL-BODY (12V RH)
 SHEET 5 OF 5