



**DANGER**

**Danger of electrical shock, burns or death.** Always remove all power sources before attempting any repair, service or diagnostic work. Power can be present from shore power, generator, inverter or battery. All power sources must be disabled and secured before performing any service.



**CAUTION**

If you lack the skills, tools or equipment to perform diagnostic or repair work leave such work to an authorized Winnebago Industries dealer or other qualified shop.

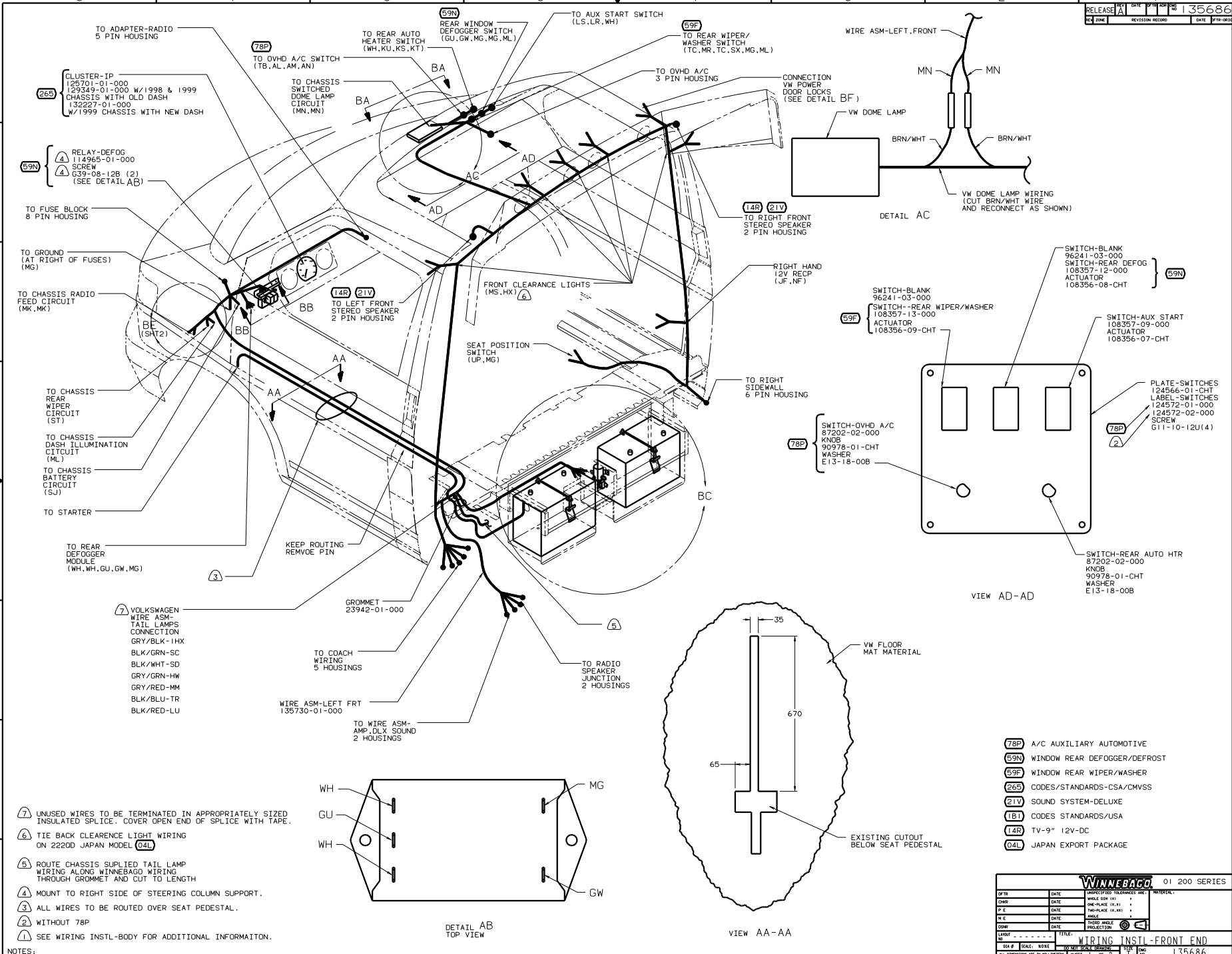

(26S) CLUSTER-IP  
 125701-01-000  
 129349-01-000 W/1998 & 1999  
 CHASSIS WITH OLD DASH  
 132227-01-000  
 W/1999 CHASSIS WITH NEW DASH

(59N) RELAY-DEFOG  
 114965-01-000  
 SCREW  
 639-08-12B (2)  
 (SEE DETAIL A(B))

TO FUSE BLOCK  
 8 PIN HOUSING

TO GROUND  
 (AT RIGHT OF FUSES)  
 (MG)

TO CHASSIS RADIO  
 FEED CIRCUIT  
 (MK, MK)

TO CHASSIS  
 REAR  
 WIPER  
 CIRCUIT  
 (ST)

TO CHASSIS  
 DASH ILLUMINATION  
 CIRCUIT  
 (ML)

TO CHASSIS  
 BATTERY  
 CIRCUIT  
 (SJ)

TO STARTER

TO REAR  
 DEFOGGER  
 MODULE  
 (WH, WH, GU, GW, MG)

(7) VOLKSWAGEN  
 WIRE ASM-  
 TAIL LAMPS  
 CONNECTION  
 GRY/BLK-1HX

TO COACH  
 WIRING  
 5 HOUSINGS

WIRE ASM-LEFT FRT  
 135730-01-000

TO WIRE ASM-  
 AMP. DLX SOUND  
 2 HOUSINGS

(1) UNUSED WIRES TO BE TERMINATED IN APPROPRIATELY SIZED INSULATED SPLICE. COVER OPEN END OF SPLICE WITH TAPE.

(2) TIE BACK CLEARANCE LIGHT WIRING ON 2220D JAPAN MODEL (04L)

(3) ROUTE CHASSIS SUPPLIED TAIL LAMP WIRING ALONG WINNEBAGO WIRING THROUGH GROMMET AND CUT TO LENGTH

(4) MOUNT TO RIGHT SIDE OF STEERING COLUMN SUPPORT.

(5) ALL WIRES TO BE ROUTED OVER SEAT PEDESTAL.

(2) WITHOUT 78P

(1) SEE WIRING INSTL-BODY FOR ADDITIONAL INFORMATION.

NOTES:

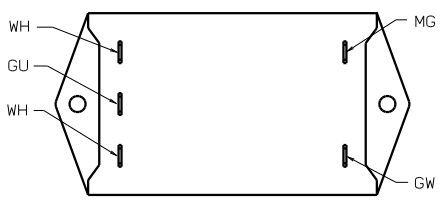

DETAIL AB  
 TOP VIEW

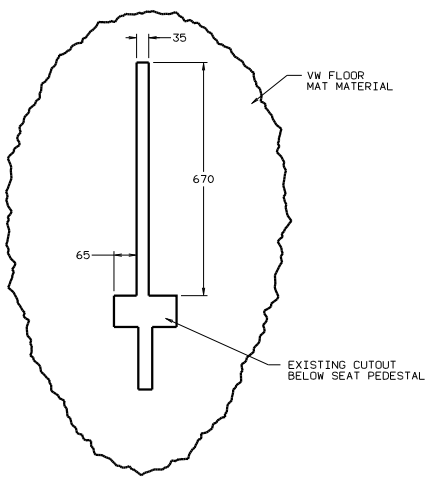

VIEW AA-AA

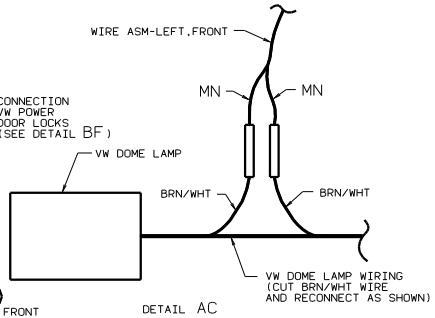

DETAIL AC

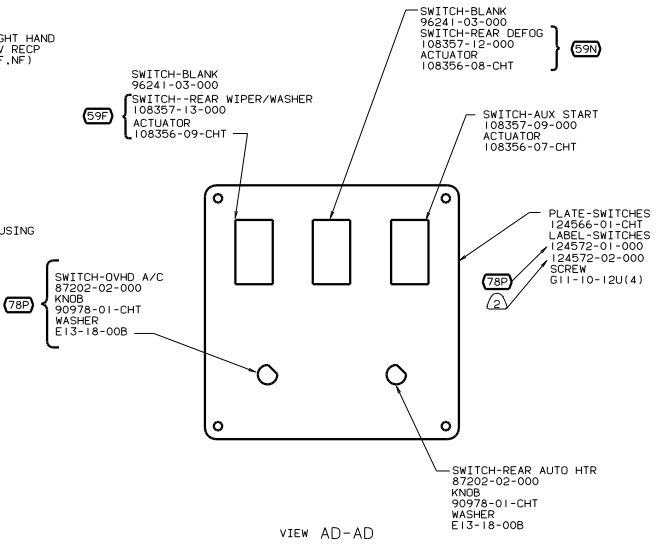

VIEW AD-AD

- (78P) A/C AUXILIARY AUTOMOTIVE
- (59N) WINDOW REAR DEFOGGER/DEFROST
- (59F) WINDOW REAR WIPER/WASHER
- (26S) CODES/STANDARDS-CSA/CMVSS
- (21V) SOUND SYSTEM-DELUXE
- (1B1) CODES STANDARDS/USA
- (14R) TV-9" 12V-DC
- (04L) JAPAN EXPORT PACKAGE

WINNEBAGO 01 200 SERIES			
OF IN	DATE	UNSPECIFIED TOLERANCES ARE:	MATERIAL
CHP	DATE	FRAC-PLS (FR. PL)	
PL	DATE	FRAC-PLS (FR. PL)	
PL	DATE	FRAC-PLS (FR. PL)	
COMP	DATE	FRAC-PLS (FR. PL)	

WIRING INSTL-FRONT END  
 SHEET 1 OF 2  
 REF: 133516 H 135686

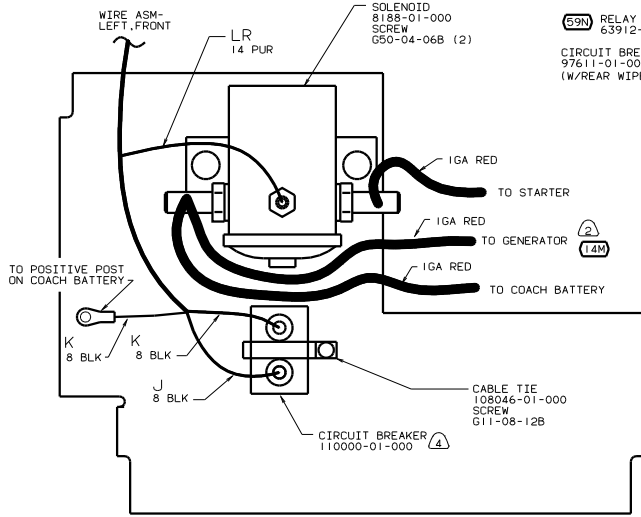

VIEW BD-BD (SHELL ONLY)

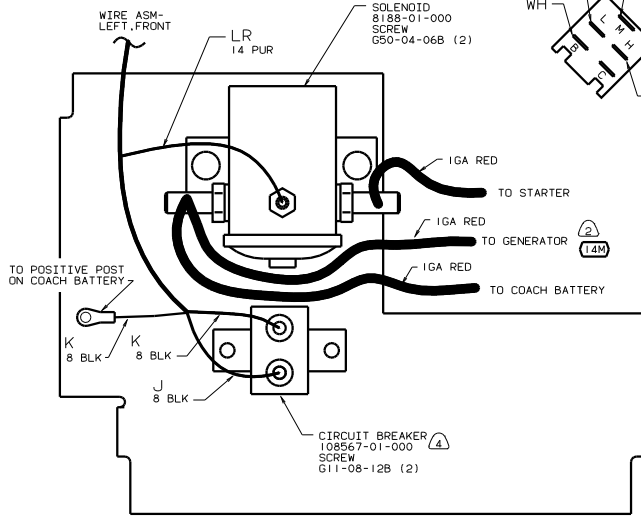
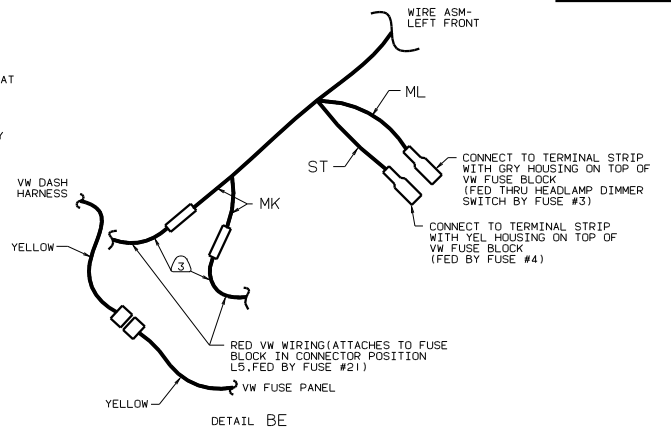
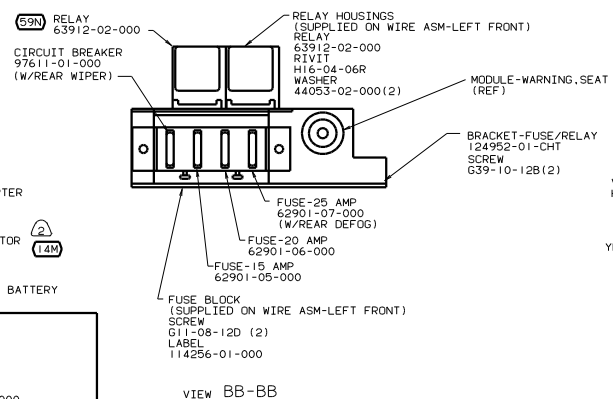

VIEW BD-BD (ALL BUT SHELL)

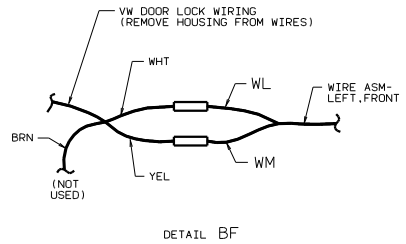
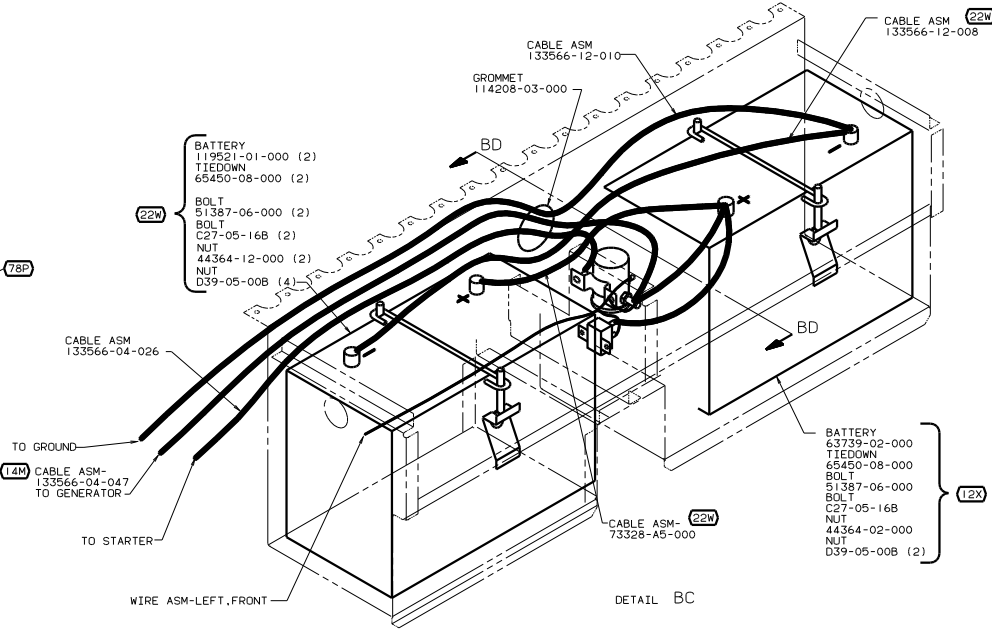
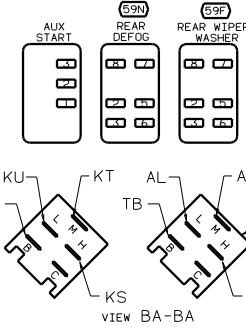

- ⚠ SEAL SEAMS AND TOP OF CIRCUIT BREAKER WITH SEALANT 117082-01-000. MINIMIZE CONTACT OF SEALANT WITH ELECTRICALLY CONDUCTIVE SURFACES.
- ③ CUT WIRE AND RECONNECT AS SHOWN.
- ② SEE GENERATOR INSTL FOR ADDITIONAL INFORMATION.
- ① SEE WIRING INSTL-BODY FOR ADDITIONAL INFORMATION.

- 78P A/C AUXILIARY AUTOMOTIVE
- 59N WINDOW REAR DEFOGGER/DEFROST
- 59P WINDOW REAR WIPER/WASHER
- 265 CODES/STANDARDS-CSA/CMVSS
- 22W BATTERY-TWO
- 1B1 CODES STANDARDS/USA
- 14M GENERATOR-3,000W-GENERAC GAS
- 12X BATTERY-ONE