



## INSTALLATION MANUAL

For Furnace Models  
NT-12SE • NT-16SE • NT-20SE

The design of these furnaces have been certified for installation in recreational vehicles only. In order for these furnaces to operate in conformity with generally accepted safety regulations, the installation instructions outlined in this book must be followed. Failure to comply with the installation instructions will void any responsibility of Suburban Manufacturing Company. Your furnace was inspected before it left the factory. If any parts are found to be damaged, do not install the furnace. Any damages should be reported to the transportation company immediately and the appropriate claims filed.

**WARNING!** Improper installation, adjustment, alteration, service or maintenance can cause property damage, personal injury or loss of life. Refer to the installation instructions and/or owners manual provided with this appliance.

**WARNING:** If the information in this manual is not followed exactly, a fire or explosion may result causing property damage, personal injury or loss of life.

Do not store or use gasoline or other flammable vapors and liquids in the vicinity of this or any other appliance.

### WHAT TO DO IF YOU SMELL GAS

- Extinguish any open flame.
- Evacuate all persons from the vehicle.
- Shut off the gas supply at the gas container or source.
- Do not touch any electrical switch, or use any phone or radio in the vehicle.
- Do not start the vehicle's engine or electric generator.
- Contact the nearest gas supplier or qualified service technician for repairs.
- If you cannot reach a gas supplier or qualified service technician, contact the nearest fire department.
- Do not turn on the gas supply until the gas leak(s) has been repaired.

Installation and service must be performed by a qualified installer, service agency or the gas supplier.

### INSTALLATION INSTRUCTIONS

**WARNING!** Installation of this appliance must be made in accordance with the written instructions provided in this manual. No agent, representative or employee of Suburban or other person has the authority to change, modify or waive any provision of the instructions contained in this manual.

**CAUTION:** If possible, do not install the furnace to where the vent can be covered or obstructed when any door on the trailer is opened. If this is not possible, then the travel of the door must be restricted in order to provide a 6" minimum clearance between the furnace vent and any door whenever the door is open. **NOTE:** The exhaust temperature of this furnace could discolor or warp some materials. You should verify that the material used on the coach door, panel, or cover will not discolor or warp from the exhaust temperature whenever any door, panel, or cover is in the open position.

**CAUTION:** Due to the differences in vinyl siding, this appliance should not be installed on vinyl siding without first consulting with the manufacturer of the siding or cutting the siding away from the area around the appliance vent.

**CAUTION:** In any installation in which the vent of this appliance can be covered due to the construction of the RV or some special feature of the RV such as slide out, pop-up, etc. always insure that the appliance cannot be operated by setting the thermostat to the positive "OFF" position and shutting off all electrical and gas supply to the appliance. Never operate furnace with vent covered.

**NOTE:** These furnaces must be installed and vented as described in this manual so that the negative pressure created by the air circulating (return air) fan cannot affect the combustion air intake or venting of any other appliance. It is imperative that the products of combustion be properly vented to the atmosphere and that all combustion air supplied to burner be drawn from the outside atmosphere. (See "Installing Vent Assembly".)

**NOTE:** These furnaces shall be installed so the electrical components are protected from water.

These furnaces will accommodate an installation depth from 21" to 27 3/4", depending on the intake vent tube length you select. (See Figure 1.)

Please adhere strictly to the following instructions to insure proper installation and safe operation, as well as adequate clearances for accessibility.

The efficiency rating of the appliance is a product thermal efficiency rating determined under continuous operating conditions and was determined independently of any installed system.

These furnaces are certified for use with propane/LP gas only. Gas supply pressure for purposes of input adjustment:

Gas	Minimum	Maximum
Propane/LP	11" W.C.*	13" W.C.
*Water Column		

In the USA, the installation must conform with local building codes. In the absence of local building codes, refer to the latest edition of:

- 1-Standard for Recreational Vehicles ANSI A-119.2/NFPA 501C.
- 2-National Fuel Code ANSI Z223.1.
- 3-The furnace must be electrically grounded in accordance with the latest edition of the National Electrical Code ANSI/NFPA No. 70.
- 4-The installation of the furnace shall be in accordance with any applicable local codes and regulations.

In Canada, the furnace must be installed in accordance with:

- 1-Standard CAN/CSA-Z240 Recreational Vehicles
- 2-CSA Standard CAN/CSA-Z240.6.2-M86 Electrical Requirements for Recreational Vehicles.
- 3-Standard CAN/CSA-Z240.4.2-M86 Installation Requirements for Propane Appliances and Equipment in Recreational Vehicles.
- 4-CAN/CGA-B149 Installation Codes
- 5-Any applicable local codes and regulations.

The furnace cabinet must extend through the coach cabinetry 1 3/8" as shown in Figure 1. The 1 3/8" extension must be held in order to assure that the front grille will properly attach to the furnace cabinet. Adequate clearances must be maintained around furnace cabinet so that the unit will be accessible for servicing.

## TO INSTALL THE FURNACE

1. Locate the furnace near lengthwise center of the coach. Do not install the furnace with the vent facing toward the forward end of the coach.
2. Select a location for installation out of the way of wires, pipes, etc. that might interfere with installation. Adhere to the following minimum clearances from the furnace cabinet to combustible construction.

Back - 0"	Top - 5/8"
Floor - 0"	Sides - 5/8"

NOTE: Side and top clearances of furnace cabinet may be 0" for through the wall installations up to a maximum of 2 1/2" wall thickness (See Figure 2.)

The following minimum clearances from the warm air discharge grille to combustible materials must be maintained:

Models NT-12SE, NT-16SE, NT-20SE			
Front - 24"	Top - 1"	Floor - 1/4"	
Left Side - 1"	Right Side - 8"	or	Left Side - 8" Right Side - 1"
(See Figure 8)			
Models NT-12SE and NT-16SE only			
Front - 12"	Top - 1"	Floor - 1/4"	
	Side 0"		
*NOTE: Must provide an additional 12 sq. in. of return air when side clearance is 0" - 8" (See Figure 9)			

3. When an appliance is installed directly on carpeting, tile, or other combustible material other than wood flooring, the appliance shall be installed on a metal or wood panel extending the full width and depth of the appliance. If preferred, the carpeting, tile or combustible materials, other than wood may be cut away the full length and depth of the appliance plus the appliance minimum clearances to combustibles.

4. Cut or frame an opening in the coach cabinetry 10 9/16" x 10 3/16" as shown in Figure 2 or Figure 3.

5. Slide the front of the furnace through the opening and extend it beyond the coach cabinetry 1 3/8" as shown in Figure 2 or Figure 3.

6. Determine "X" dimension as shown in Figure 1.

7. Determine "Y" dimension as shown in Figure 1.

8. If X - Y is less than 21", then an opening 9 5/8" x 9 3/8" must be cut through the inner wall only. **DO NOT CUT THROUGH COACH SKIN.** (See Figure 2.) Next, locate the center line of the exhaust and intake tube. Cut two 2 1/4" diameter holes through the outer skin as shown in Figure 4.

NOTE: Whenever the furnace cabinet is installed through the outside wall, the return air louvers on the furnace cabinet must not be blocked. The maximum projection of the furnace cabinet into the wall is 2 1/2". (See Figure 2.)

NOTE: Furnace cabinet approved for 0" clearance to combustible materials rear 2 1/2" of furnace cabinet.

9. If X - Y is 21" or greater, two methods may be used to install the furnace.

a. Cut a 4" x 7 1/2" opening through combustible wall as shown in Figure 3. **DO NOT CUT THROUGH TRAILER SKIN.** Next, locate the center line of the exhaust and intake tube. Cut two 2 1/4" diameter holes through trailer skin. (See Figure 4.)

b. If you do not wish to cut the 4" x 7 1/2" opening, locate the center line of the exhaust and intake tube as shown in Figure 4. Next, cut two 2 3/4" diameter holes through trailer skin and also the combustible wall of the trailer as illustrated in Figure 6. Care must be taken when locating the center line of the exhaust and intake tube as well as when cutting the holes in order to assure a 3/8" clearance around the exhaust and intake tube to combustible materials.

10. Refer to the chart in Figure 1 and select the range for which the 'X' dimension falls. The intake tube length directly to the left of the selected range is the length required. NOTE: The 7 3/4" length exhaust tube assembly will accommodate all approved installation depths - only the intake tube must be ordered when needed. Under no circumstances should the standard 5" intake tube be cut or altered to adapt to the 21" - 23 1/4" range.

11. Secure furnace to the floor using the two holes provided in the front area of the furnace cabinet. (See Figure 2 or Figure 3.)

12. NOTE: OPTIONAL DISCHARGE DUCT ADAPTER -The cabinet has a 4" diameter knockout on the left side of cabinet. (See Figure 6A.) A 4" diameter connector can be attached to this location to provide a warm air discharge duct. (Not to exceed 10" in length.)

## CONNECTING GAS SUPPLY

A 3/8" flare connection is provided on the right side of the furnace for the gas supply connection to the furnace.

NOTE: Be sure all male joints have been treated with a sealing compound resistant to the action of liquefied petroleum (LP) gas.

In order to maintain a check on gas supply pressure to the furnace. Suburban advises the installer to provide a 1/8" NPT plug tap for test gauge connection immediately upstream of the gas supply connection to the furnace.

NOTE: The appliance must be disconnected from the gas supply piping system during any pressure testing of that system at test pressure in excess of 1/2 PSIG.

The appliance must be isolated from the gas supply piping during any pressure testing of the gas supply piping system at test pressure equal to or less than 1/2 PSIG.

**WARNING! All joints must be checked for leaks. Do not use open flame to check for leaks! Use a soap and water solution.**

## CONNECTING ELECTRICAL SUPPLY

**CAUTION:** These furnaces are designed for a negative ground 12 volt D.C. system only. Do not attempt to alter the furnace for a positive ground system or connect the furnace directly to 115 volts A.C. Damage to furnace component parts will occur.

Be sure all wiring to the furnace is of heavy enough gauge to keep the voltage drop through it to a minimum. No. 12 gauge wire is recommended. If any of the original wire that is supplied with the appliance must be replaced, it must be replaced with Type 105° Cor its equivalent.

Connect the power supply to the red and yellow wires on the right side of the furnace. The wires are color coded, red for positive (+) and yellow for negative (-). This polarity must be observed so the furnace motor will run with the proper direction of rotation to insure correct air delivery. (See wiring diagram.)

If the furnace power supply is to be from a convertor, we recommend that the convertor system used to power the furnace be wired in parallel with the battery. This will serve two purposes:

1. Provide a constant voltage supply to the furnace.
2. Filter any A.C. spikes or volt surges.

NOTE: Furnace models NT-12SE, NT-16SE AND NT-20SE are equipped with an electric ignitor device that has an energy consumption of .1 amps at 12 volts D.C.

## CONNECTING THERMOSTAT

Locate the room thermostat approximately 4 1/2 feet above the floor on an inside bulkhead where it is not affected by heat from any source except room air.

Connect the thermostat wires to the blue wires on the right side of the furnace (See wiring diagram.)

## INSTALLING VENT ASSEMBLY

The vent outlet must be installed so it is in the same atmospheric pressure zone as the combustion air intake. The exhaust and intake tubes must be installed from the outside, pass through the RV skin and slide onto the furnace exhaust and intake.

**WARNING! Do not alter the vent assembly supplied with this furnace. Any modifications will result in improper installation which could cause unsafe furnace operation.**

**CAUTION! Combustion air must not be drawn from the living area. All air for combustion must be drawn from the outside atmosphere. All exhaust gases must be vented to the outside atmosphere - never inside the RV. Therefore, it is essential to insure that the vent cap and tube assemblies are properly installed.**

1. Apply caulking to RV skin behind vent cap as shown in Figure 6. Apply caulking generously around perimeter of vent cap and across center as shown.
2. Insert intake tube through RV skin and slide it onto the furnace intake (See Figure 1.) Minimum tube overlap of 1/2" is required.
3. Insert vent cap exhaust tube through RV skin and slide it onto the furnace exhaust (See Figure 1.) Minimum tube overlap of 1 1/4" is required.
4. Attach vent cap assembly to outer skin of RV with the six (6) screws provided. Do not install vent assembly upside down. The words "Suburban" and "Dayton, Tenn." must be right side up.

**Due to high temperatures, the unit should be located out of traffic and away from furniture and draperies.**

**Children and adults should be alerted to the hazards of high surface temperatures and should stay away to avoid burns or clothing ignition.**

**Young children should be carefully supervised when they are in the same room as the unit.**

**Clothing or other flammable material should not be placed on or near the unit.**

**Any safety screen or guard removed for servicing the unit must be replaced prior to operating the unit.**

**The area around the unit must be kept clear from combustible materials, gasoline and other flammable vapors and liquids.**

**Installation and repairs should be done by a qualified service person. The unit should be inspected before use and at least annually by a qualified service person. More frequent cleaning may be required due to excessive lint from carpeting, bedding material, etc. It is imperative that control compartments, burners, and circulating air passageways of the unit be kept clean.**

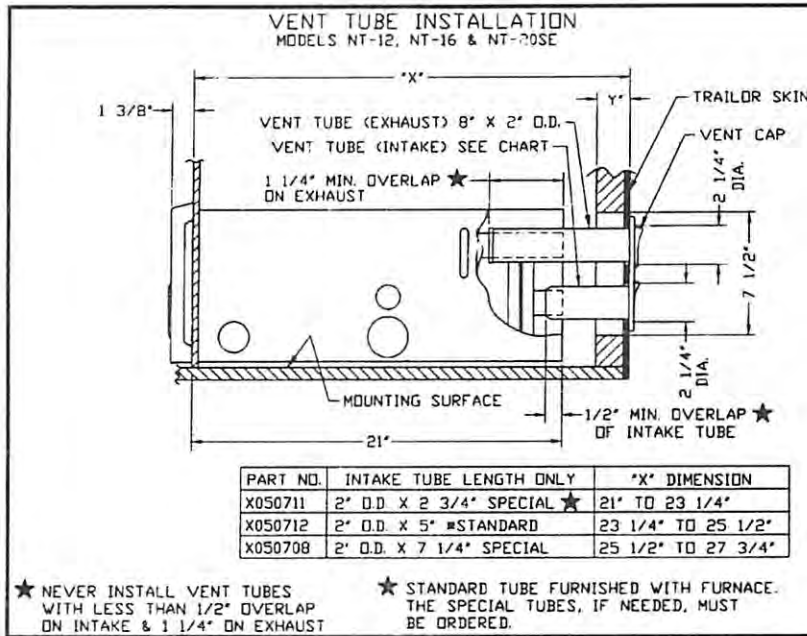

Figure 1

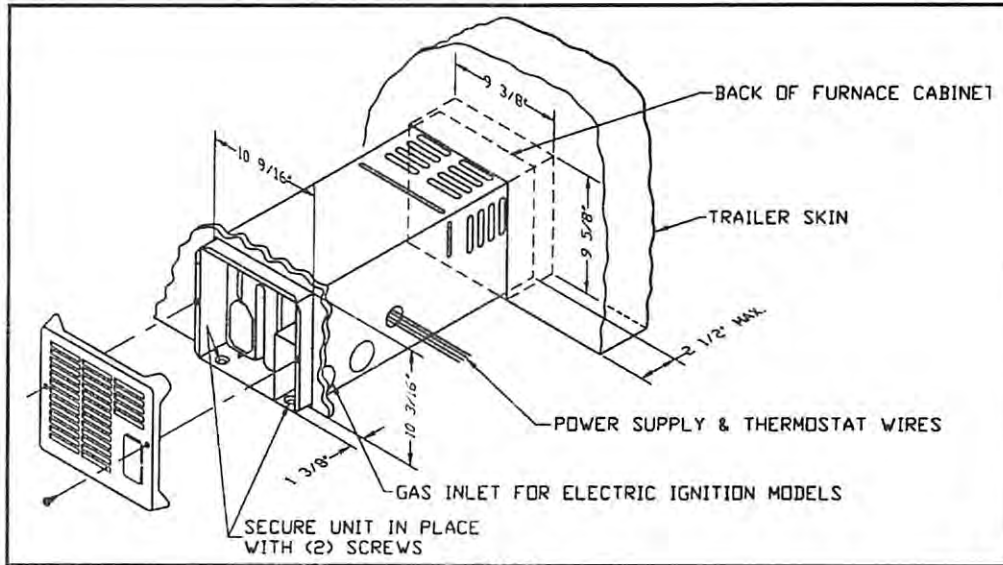

Figure 2

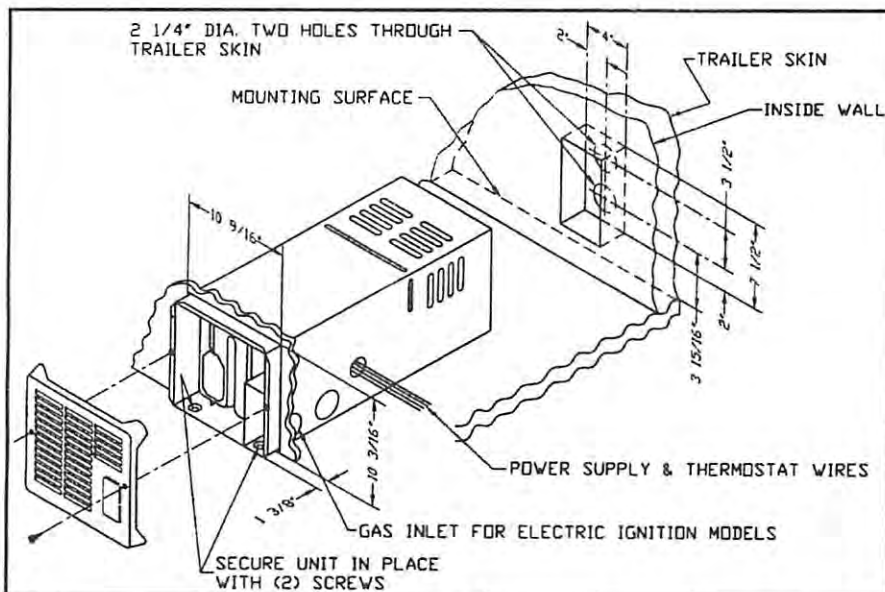

Figure 3

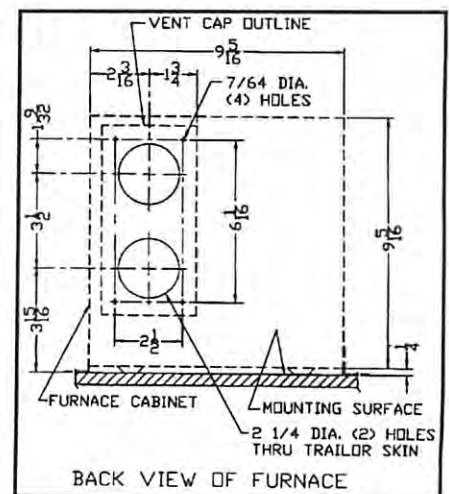

Figure 4

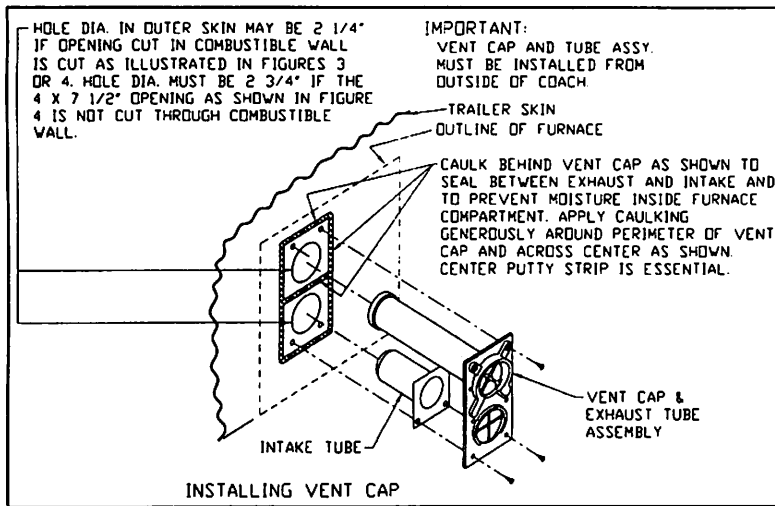

Figure 6

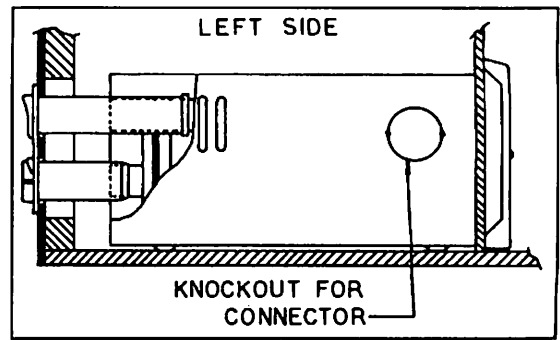

Figure 6A

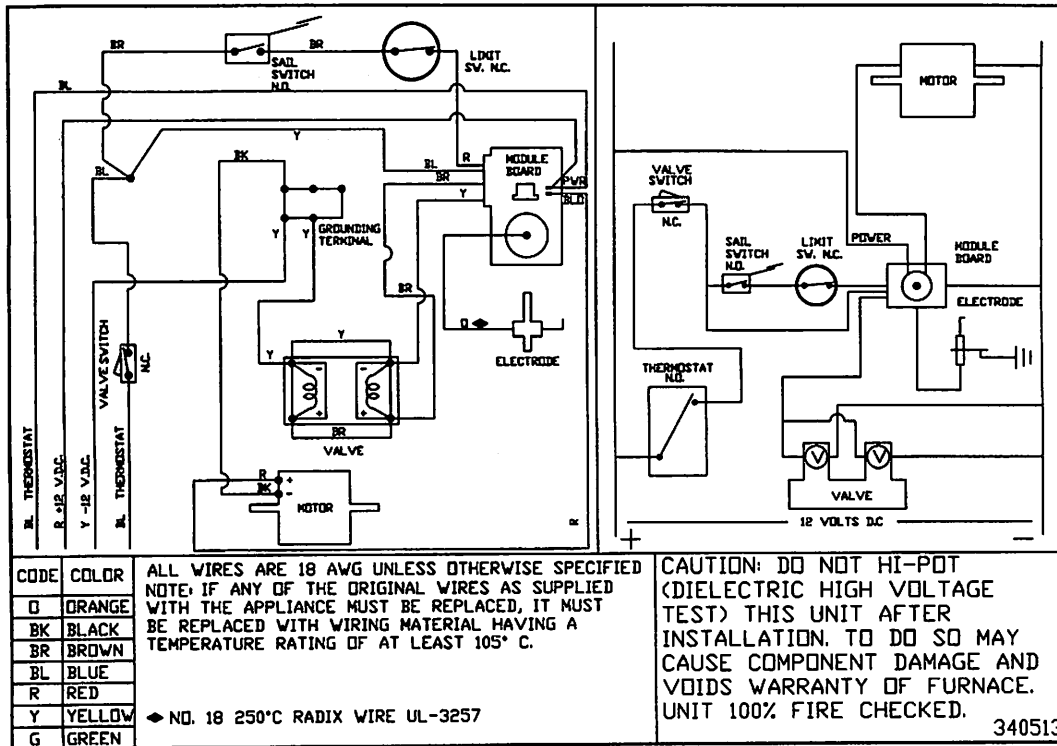

Figure 7

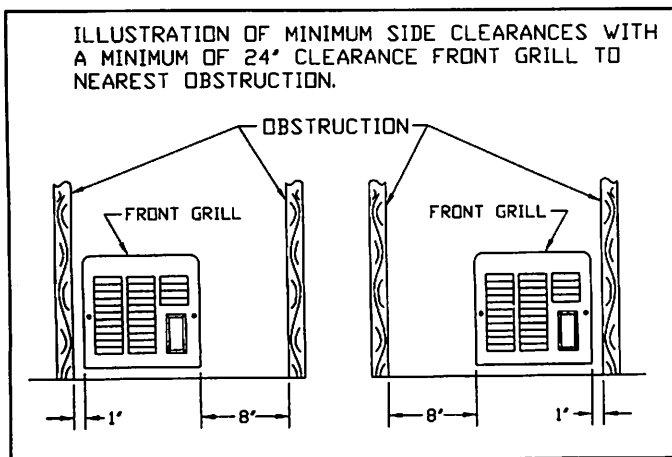

Figure 8  
 For Models NT-12SE, NT-16SE, NT-20SE

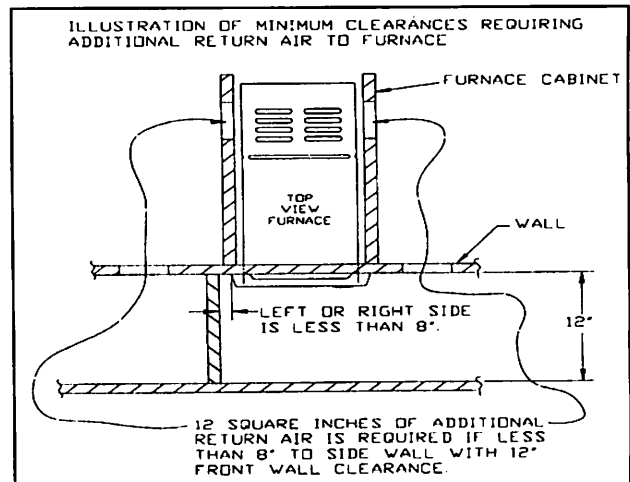

Figure 9  
 For Models NT-12SE, NT-16SE